

Panasonic®

Operating Instructions

Memory Card Camera-Recorder

P2HD

Model No. **AG-HPX500P**

Model No. **AG-HPX500E**

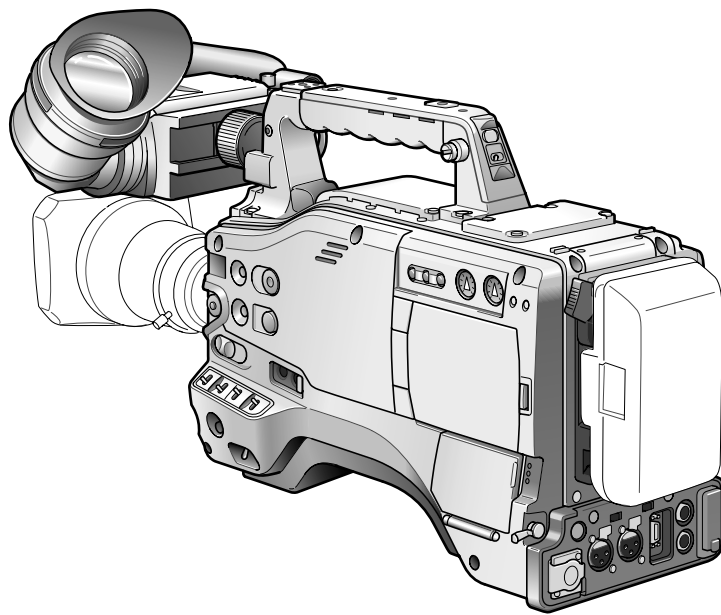

FRANÇAIS

Pour des explications en français, veuillez vous reporter au CD-ROM fourni.



DVCPRO HD



DVCPRO 50

DVCPRO

DV

Before operating this product, please read the instructions carefully and save this manual for future use.

Read this first!

	CAUTION RISK OF ELECTRIC SHOCK DO NOT OPEN	
<p>CAUTION: TO REDUCE THE RISK OF ELECTRIC SHOCK, DO NOT REMOVE COVER (OR BACK). NO USER-SERVICEABLE PARTS INSIDE. REFER SERVICING TO QUALIFIED SERVICE PERSONNEL.</p>		



The lightning flash with arrowhead symbol, within an equilateral triangle, is intended to alert the user to the presence of uninsulated "dangerous voltage" within the product's enclosure that may be of sufficient magnitude to constitute a risk of electric shock to persons.



The exclamation point within an equilateral triangle is intended to alert the user to the presence of important operating and maintenance (servicing) instructions in the literature accompanying the appliance.

WARNING:

- TO REDUCE THE RISK OF FIRE OR SHOCK HAZARD, DO NOT EXPOSE THIS EQUIPMENT TO RAIN OR MOISTURE.
- TO REDUCE THE RISK OF FIRE OR SHOCK HAZARD, KEEP THIS EQUIPMENT AWAY FROM ALL LIQUIDS. USE AND STORE ONLY IN LOCATIONS WHICH ARE NOT EXPOSED TO THE RISK OF DRIPPING OR SPLASHING LIQUIDS, AND DO NOT PLACE ANY LIQUID CONTAINERS ON TOP OF THE EQUIPMENT.

CAUTIONS:

TO REDUCE THE RISK OF FIRE OR SHOCK HAZARD AND ANNOYING INTERFERENCE, USE THE RECOMMENDED ACCESSORIES ONLY.

CAUTION:

In order to maintain adequate ventilation, do not install or place this unit in a bookcase, built-in cabinet or any other confined space. To prevent risk of electric shock or fire hazard due to overheating, ensure that curtains and any other materials do not obstruct the ventilation.

FCC Note:

This equipment has been tested and found to comply with the limits for a class A digital device, pursuant to Part 15 of the FCC Rules. These limits are designed to provide reasonable protection against harmful interference when the equipment is operated in a commercial environment. This equipment generates, uses, and can radiate radio frequency energy, and if not installed and used in accordance with the instruction manual, may cause harmful interference to radio communications. Operation of this equipment in a residential area is likely to cause harmful interference in which case the user will be required to correct the interference at his own expense.

Warning:

To assure continued FCC emission limit compliance, follow the attached installation instructions and the user must use only shielded interface cables when connecting to host computer or peripheral devices. Also, any unauthorized changes or modifications to this equipment could void the user's authority to operate this device.

Caution:

- The interior of this product contains high-voltage components. Do not disassemble the product.
- Do not point the eyepiece directly at the sun.

CAUTION:

Excessive sound pressure from earphones and headphones can cause hearing loss.

CAUTION:

Do not leave the unit in direct contact with the skin for long periods of time when in use. Low temperature burn injuries may be suffered if the high temperature parts of this unit are in direct contact with the skin for long periods of time. When using the equipment for long periods of time, make use of the tripod.

 indicates safety information.

Read this first!

<For USA and Canada>

A rechargeable battery that is recyclable powers the product you have purchased.



TO REMOVE BATTERY

Main Power Battery (Ni-Cd / Ni-MH / Li-ion Battery)

- To detach the battery, please proceed in the reverse order of the installation method described in this manual.
- If a battery made by any other manufacturer is to be used, check the Operating Instructions accompanying the battery.

Back-up Battery (Lithium Battery)

- For the removal of the battery for disposal at the end of its service life, please consult your dealer.

EEE Yönetmeliğine Uygundur.
EEE Complies with Directive of Turkey.

Pursuant to at the directive 2004/108/EC, article 9(2)

Panasonic Testing Centre

Panasonic Service Europe, a division of Panasonic Marketing Europe GmbH

Winsbergring 15, 22525 Hamburg, F.R. Germany

Precautions for Use

Caution regarding laser beams

The CCD may be damaged if it is subjected to light from a laser beam. When using the camera-recorder in locations where laser irradiation equipment is used, be careful not to allow the laser beam to shine directly on the lens.

PLEASE NOTE:

- When preparing to record important images, always shoot some advance test footage, to verify that both pictures and sound are being recorded normally.
- Should video or audio recording fail due to a malfunction of this camera-recorder or the P2 cards used, we will not assume liability for such failure.

Disposing and transferring ownership of memory card devices

Formatting or deleting a memory card device in this camera or a PC will only change file management data and leave data on the card intact. It is recommended that the card either be physically destroyed or that commercially sold software be used to completely delete any data on the card. Note that managing card data is the owner's responsibility.

Information on software for this product

1. Included with this product is software licensed under the GNU General Public License (GPL) and GNU Lesser General Public License (LGPL), and users are hereby informed that they have the right to obtain, change and redistribute the source codes of this software. Details on GPL and LGPL can be found on the installation CD provided with the unit. Refer to the folder called "LDOC".
(Details are given in the original (English-language) text.)
To obtain the source codes, go to the following home page:
<http://pro-av.panasonic.net/>
The manufacturer asks users to refrain from directing inquiries concerning the source codes they have obtained and other details to its representatives.
2. Included with this product is software which is licensed under MIT-License. Details on MIT-License can be found on the installation CD provided with the unit. Refer to the folder called "LDOC".
(Details are given in the original (English-language) text.)

Trademarks

- SD logo is a trademark.
- Multi Media Card (MMC) is a registered trademark of Infineon Technologies AG.
- Apple, Macintosh, Mac OS are registered trademarks or trademarks of Apple, Inc. in the United States and/or other countries.
- Microsoft and Windows are registered trademarks or trademarks of Microsoft Corporation in the United States and/or other countries.
- Other names of companies and products are trademarks or registered trademarks of the respective companies.

Contents

Chapter 1 Introduction

Chapter 2 Parts and their Functions

Chapter 3 Recording and Playback

Chapter 4 Adjustments and Settings for Recording

Precautions for Use	4
Camera Unit Features	8
Recording and Playback Features	10
Outline of operations	12
Flow of shooting, playing and saving	12
Saving and editing on external devices	13
System Configuration	14
Power Supply and Accessory Mounting Section	15
Audio (input) Function Section.....	16
Audio (output) Function Section	18
Shooting and Recording/Playback Functions Section	19
Menu/Thumbnail Operation Section.....	24
Time Code Section	25
Warning and Status Display Functions	26
LCD Monitor	26
Viewfinder	27
Setting Date and Time of Internal Clock	28
P2 Cards	30
Inserting P2 Cards	30
Removing P2 Cards	31
To Prevent Accidental Erasure of P2 Card Content.....	32
P2 CARD ACCESS LED and status of P2 cards	32
P2 card recording times	32
Handling P2 Card Recording	32
Basic Procedures	34
Shooting	35
Normal Recording	36
Variable Frame Rate (VFR) Recording	37
Native recording	37
Standard recording	38
Using variable frame rates (VFR)	38
Shooting in the 1080i/480i Progressive Mode	39
Special Recording Modes	40
Pre-recording (PRE REC).....	40
Interval recording (INTERVAL REC).....	40
One-shot recording (ONE-SHOT REC).....	41
Loop recording (LOOP REC)	42
Hot Swap Recording	42
Recording Check Function.....	43
Shot Marker (SHOT MARK) Recording Function	43
Text Memo Recording Function	43
Normal and Variable Speed Playback	44
Video and recording formats	45
Multiple HD/SD formats	45
Selecting recording signals in CAMERA MODE.....	45
Selecting MCR mode recording and playback signals	46
Selecting video output.....	46
List of recording, playback and output formats.....	47
Adjusting the White balance and Black Balance	50
Adjusting the White Balance	50
Adjusting the Black Balance	51
Setting the Electronic Shutter	53
Setting the Shutter Mode and Speed.....	53
Placing the Camera-recorder in SYNCHRO SCAN Mode.....	54
Assigning functions to USER buttons	55
Selecting Audio Input Signals and Adjusting Recording Levels	56
Selecting Audio Input Signals	56
Adjusting Recording Levels	56
Selecting Function for the FRONT AUDIO LEVEL Control	57
CH3 and CH4 Recording Levels	57
Setting Time Data	58
Time data overview	58

Recording time codes and user bits	59
Setting user bits	60
Entering the User Bits	60
Setting the Time Code	62
Externally Locking the Time Code	64
Outputting the time code externally	65
GENLOCK and time code input/output connection and setup	66
Counter Setting and Display	66
Viewfinder Screen Status Displays	67
Lamps in the Viewfinder Screen	67
Viewfinder Status Indication Layout	67
Selecting Viewfinder Display Information	67
Screen displays	68
Warnings	71
P2 card playback data indication	71
Errors	72
Camera status display	72
USER buttons assignment information (at mode check)	72
! LED light indication (at mode check)	72
Checking and displaying shooting status	73
Setting the Marker Displays	74
Adjusting and setting the LCD monitor	75
Handling setup data	77
Configuration of setup data files	77
Handling SD memory cards	78
Formatting, Writing and Reading an SD memory card	78
How to Use Scene File Data	79
Saving scene files and other settings on SD memory cards	82
Memory Card Usage	83
Power Supply	84
Mounting the Battery and Setting the Battery Type	84
Use of the external DC power supply	86
Mounting the Viewfinder and Adjusting its Position	88
Mounting the Viewfinder	88
Adjusting Viewfinder Right-Left Position	88
Diopter Adjustments	89
Screen Adjustments	89
Removing the Viewfinder	90
Mounting and Adjusting the Lens	91
Mounting the Lens	91
Adjusting the Lens Flange Back	92
White Shading Compensation	92
Setting Chromatic Aberration Compensation (CAC)	95
Preparing for Audio Input	98
When Using the Front Microphone	98
When Using Audio Devices	99
Attaching Accessories	100
Mounting the Camera on a Tripod	100
Attaching the Shoulder Strap	101
Attaching the Rain Cover	101
Attaching the FRONT AUDIO LEVEL Control Knob	101
Connecting the AJ-RC10G Extension Controller	102
Thumbnail Operations	103
Thumbnail Overview	103
Thumbnail Screen	104
Selecting Thumbnails	104
Switching the Thumbnail Display	105
Setting the Thumbnail Display Mode	106
Clip Operations	107
Playing Back Clips	107
Shot Mark	107
Deleting Clips	108
Restoring Clips	108

Chapter 5 Preparation

Chapter 6 Manipulating Clips with Thumbnails

Chapter 7 Menu Operations

Setting of Clip Meta Data	109
Formatting P2 and SD Memory Cards	112
Formatting a P2 Card	112
Formatting SD memory cards	112
Properties	113
Clip Property	113
P2 Card Status Display	113
SD memory card Status Display	115
Confirmation of Metadata Upload	115
Viewfinder and LCD Menus	116
Using the menus	116
Initializing the menu settings	117
Setup menu structure	118
Camera (CAM) mode menu	118
MCR mode menu	119
Setup menu list	120
SCENE FILE screen	120
CAMERA SETUP screen	121
SW MODE screen	122
RECORDING SETUP screen	123
AUDIO SETUP screen	124
OUTPUT SEL screen	125
DISPLAY SETUP screen	125
VF! LED screen	126
BATTERY SETUP screen	127
CARD FUNCTION (SD memory card setting) screen	128
LENS SETUP screen	128
OTHER FUNCTIONS screen	129
OPTION MENU screen	130

Chapter 8 Connecting to External Devices

Connecting to External Devices Using USB2.0 Port (PC mode)	131
Procedures for establishing a connection with a PC	131
Connecting to External Devices Using the IEEE1394 Connector (PC mode)	132
Procedures for establishing a connection with a PC	132
Procedures for connecting a hard disk	133
Warnings	134
DVCPRO/DV Connection via IEEE1394 Connector	135
Recording DVCPRO/DV signals input to 1394 connector	135

Chapter 9 Maintenance and Inspections

Inspections Before Shooting	137
Preparing for Inspections	137
Inspecting the Camera Unit	138
Inspecting the Memory Recording Functions	138
Maintenance	141
Cleaning Inside the Viewfinder	141
Eyepiece Care	141
Phenomenon Inherent to CCD Cameras	141
Charging the internal battery	141
Warning System	142
Warning Description Tables	142
Updating Camera Drivers	144

Chapter 10 Specifications

Dimensions and specifications	145
Dimensions	145
Specifications	146
Connector signal description	149

Chapter 1 Introduction

The AG-HPX500P/E memory card camera recorder is equipped with a 2/3-type lens mount system that enables use of high-performance interchangeable lenses, and comes with a 50 Hz/59.94 Hz selector function to permit use of a multitude of HD and SD formats. Also equipped with a variable frame rate feature for cinematic expression and effects. All these features make possible recording of high-quality image content.

Four P2 card slots enable extended HD recording and deliver the reliability, speed and IT functionality that only P2 media is capable of revolutionizing the workflow of recording and editing.

Camera Unit Features

■ 2/3-type interchangeable lens system

The 2/3-type bayonet mount for interchangeable lenses provides access to a broad lineup of broadcast and industrial 2/3-type zoom lenses from a number of manufacturers.

■ Progressive 3CCD

The 2/3-type progressive 3CCD combines a large light-receiving area with high sensitivity. 3CCD pixel-shift technology (1/2 pixel) and advanced digital processing produce a high-resolution CCD. The camera unit provides high resolution and high rate scanning at 1080/60P (or 50P) at all times. This high-resolution native progressive video is used as a source to produce a vertical resolution with a superior HD/SD image quality that an interlace CCD simply cannot match.

■ 14-bit digital circuit

The high-performance DSP (Digital Signal Processor) in the camera uses 14-bit A/D conversion and 19-bit inner processing to adjust the gamma settings for each of the R, G and B channels of 1080/60P (50P) video, and convert to a variety of HD and SD formats (P/I conversion, line conversion and down conversion). This produces high-quality images in all video formats.

■ Multiple HD/SD formats

The camera supports recording in 20 HD and SD image formats making it ready for news gathering, program production, film making and other applications anywhere in the world. 1080i/720P HD recording uses the DVCPRO HD codec for broadcast use while SD recording is performed in DVCPRO50 / DVCPRO/DV multi-codec.

■ Variable frame rate makes speed effects possible (when 720P format is selected)

This camera comes with the variable frame rate feature developed for the VariCam HD Cinema camera. In 720P mode*, the camera enables selection between 11 frame rates between 12P to 60P (50P). This puts features such as undercranking (dropping frames) and overcranking (high frame rate) for quick motion and slow motion cine-like effects at the disposal of the camera crew.

* In 1080 and 480 mode, the camera records at a fixed frame rate of 24P/30P (25P in 1080 and 576 mode, at 50 Hz mode).

■ Native mode/Over 60P (50P) mode selectable

● 720PN (native) mode*: Recording is performed at the frame rate set in the camera. Playing back a recording made at a frame rate set in the camera at the normal rate provides speed effects without using a frame rate converter. Native mode also extends the recording time.

● 720P over 60P (or 50P) mode: This lets you produce a backup copy by recording the DVCPRO HD stream output from the IEEE1394 connector on a hard disk recorder such as the AJ-HD1400 DVCPRO HD recorder or the FOCUS FS-100 HDD recorder.

* In 720PN (native) mode, the IEEE1394 connector cannot output a DVCPRO HD stream.

■ 1080/480 24P advance mode

In 59.94Hz mode, recording at 1080/24P or 480/24P allows you to select 24PA (advance) mode. Using 2:3:3:2 pulldown, the 24PA mode performs 60i conversion to enable nonlinear editing* maintaining an image quality that is better than normal 24P (2:3 pulldown). Recording at 30P or 25P (50 Hz mode) applies a 2:2 pulldown.

* For details on compatible systems, visit our website at:

<http://pro-av.panasonic.net/>

* 24P, 30P and 60P/60i indicate recording at 23.98P, 29.97P and 59.94P/59.94i, respectively.

■ Eight gamma curves, including cine-like gamma

The DSP provides Panasonic's proprietary selectable gamma feature. To expand camera capabilities, the camera offers eight gamma modes including cine-like gamma to give the characteristic warm tone of film recordings and a news gamma curve for newsgathering.

■ Slow, synchro and high speed shutter

The shutter speed can be set in a range between 1/12 s to a maximum speed of 1/2000 s. Combined with the variable frame rate functions, this function allows you to create a blurring effect or an undercranking effect. The camera also features a synchro scan function for capturing screen shots from a computer monitor.

■ Scene file dial

This dial allows you to instantly retrieve settings that suit shooting conditions. Six preset files are provided, and you can change the file names and their settings as desired. You can also save up to 4 files to an SD memory card and load the files from the card.

■ Shooting assist functions

- User buttons: Three user buttons each of which can be assigned a frequently used function for immediate access.
- Focus assist: Displays a frequency distribution graph of the video signal as an aid in focusing.
- Eight files for correcting lens aberration and four files for correcting shading for interchangeable lenses are provided.
- Variable color temperature: Fine adjustment is possible after setting the white balance.
- REC check: Quick check of the last portion recorded results.
- 4-position optical ND filter provided.

■ Chromatic aberration compensation (CAC)

This function automatically corrects the registration error caused by the slight chromatic aberration that the lens cannot compensate for, in order to minimize color bleeding into surrounding image areas.

■ Remote control support

The camera supports the AJ-RC10G (optional accessory) remote control unit. The remote control allows you to adjust camera image and recording controls at a distance while viewing what you are shooting.

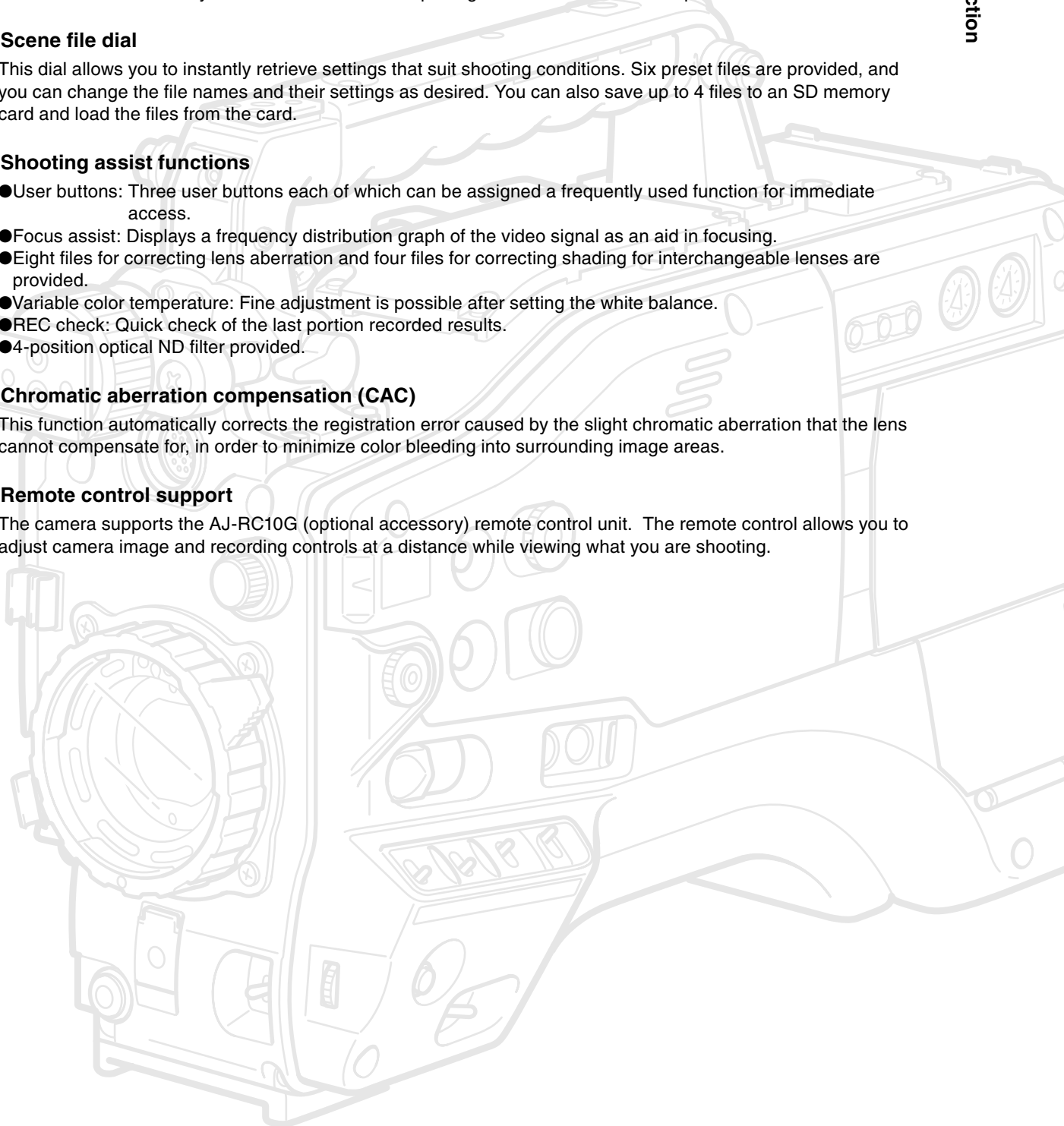

Recording and Playback Features

■ A variety of interfaces

The AG-HPX500P/E can record 48 kHz/16-bit uncompressed high-quality digital audio in all formats. The 4-channel audio capability makes both microphone and line input possible on up to four channels. HD-SDI output, time code input and output, GEN lock input and USB 2.0 connector are also provided. Also part of standard equipment is an IEEE1394 interface (6-pin) for transfer of all HD/SD signal formats without degradation. This interface allows you to transfer video data for nonlinear editing on a Windows® PC or Macintosh® with DVCPRO HD compliant software or for backing up on a connected DVCPRO HD digital VTR (AJ-HD1400) or FOCUS FS-100 HDD recorder.

■ P2 cards for high capacity, high speed and high reliability

Comprising four SD memory cards, a P2 card is a broadcast industry standard memory card with four times the capacity of a conventional SD memory card in a compact and lightweight (45 g) design. In addition to exceptional resistance to shock, vibration and temperature fluctuations, this semiconductor memory has a reliability that guarantees long-term repeated recording/initialization that a tape or hard disk system with their moving parts could never match. The connectors are professional grade to withstand long-term continual insertion and removal.

AV data is recorded on a P2 card as a single file that is immediately accessible for nonlinear editing or transfer over a network without digitizing. Transfer speeds far surpassing those of hard disks also help to speed up production processes. The P2 card complies with PCMCIA standards and can be directly plugged into the P2 card slot on a notebook PC*1.

The four P2 card slots allow continuous recording on four P2 cards and also offer the following recording capabilities in a memory card camera-recorder.

- **Card selection:** A card in any slot can be instantly selected (switched to) in standby mode*2. Recorded content can be quickly passed on to editing or transferred to minimize interruptions in recording making it far more efficient than systems where tapes or disks have to be exchanged.
- **Hot-swap recording:** Cards can be replaced during recording. A full memory card can be replaced while recording is made on another card. Successively swapping cards in this way gives you virtually unlimited recording capacity.
- **Loop recording:** Setting the camera for consecutive overwriting, you can repeatedly rerecord on the inserted P2 cards, always maintaining a recording of the most recent, specific period of time.

*1 This requires the installation of a P2 card driver (provided with each device). The P2 card driver runs under Windows® Vista or Windows® XP.

*2 This assumes that the SLOT SEL function is assigned to a USER button (USER MAIN, USER1 or USER2).

■ Immediate startup and reliable data protection

When you press the REC button in standby mode, the camera instantly finds a blank area on the P2 card and begins recording. Unlike a VTR system, there is no need to locate a blank section before recording. It can begin recording immediately even when you are using it to preview video. In normal use, there is no chance of accidentally deleting a recording. Recordings will not be erased unless you intentionally delete a file or initialize the card.

■ Other features

- **Pre-rec:** This function provides a way to capture moments you otherwise would have missed. In the standby mode, the camera will memorize video and audio for up to 3 seconds in HD and 7 seconds in SD. Starting the recording operation will record the preset duration of video and audio already memorized in standby.
- **One-shot REC:** Convenient for producing animation, this mode records for a set time (from 1 frame to 1 second) each time you press the START button.
- **Interval REC:** Recording one frame at a time at set intervals (from 2 frames to 10 minutes), this mode is useful for monitoring, supervision and special ultra undercranking effects.

■ Clip thumbnail preview

The camera records each cut as a clip (file) and automatically attaches a thumbnail image and file information to it. To preview a clip on the LCD monitor or to check clip data, simply choose the clip you want from the list of thumbnails. These thumbnails and the file data can be viewed on a PC (P2 Viewer *) or processed in a nonlinear editing program.

* "P2 Viewer" is a Windows® PC viewing software that can be downloaded free of charge by P2 card users.

■ Shot marker and text memo

If desired, you can add a simple OK/reject shot marker to each clip either during or after recording. When a P2 card is mounted in a PC (P2 Viewer), the PC will display only marked clips.

A text memo function is also provided. Pressing the USER button to which the text memo function has been assigned anywhere in a clip during recording or in preview mode allows you to attach empty post-it like text memos (up to 100) that can later be filled with text on a PC (P2 Viewer).

■ SD memory card slot

The camera provides an SD memory card slot for saving and loading scene files and user settings. A metadata upload file (created using P2 Viewer) containing the name of the person who shot the video, the name of the reporter, the shooting location or a text memo and other information can be saved to an SD memory card. This data file can be loaded as clip metadata.

■ HD/SD SDI output and downconverter supported

Video line outputs (both BNC) are provided as standard. These outputs can flexibly handle both monitor and line recording. A down-converter is also built-in. Aspect mode can also be selected.

●SDI OUT (HD/SD): The HD-SDI output allows you to make backups on an external VTR (with HD-SDI input) in synch with REC START/STOP button operation. SD-SDI can also down convert and output HD content.

●VIDEO OUT: Outputs down converted SD video (composite video).

■ Fine adjustment of sound recording level

The camera features a front-mounted control for fine adjustment of the sound recording level. This control is particularly useful for adjusting the sound level when you have to control both video and audio recording. The control can be disabled.

Outline of operations

This unit is compatible with P2 (Professional Plug-in) cards. Excelling at high transfer speeds, the P2 card enables high vision recording and smooth editing and dubbing.

Flow of shooting, playing and saving

The setting values such as the user file are saved to and read from the SD memory card.

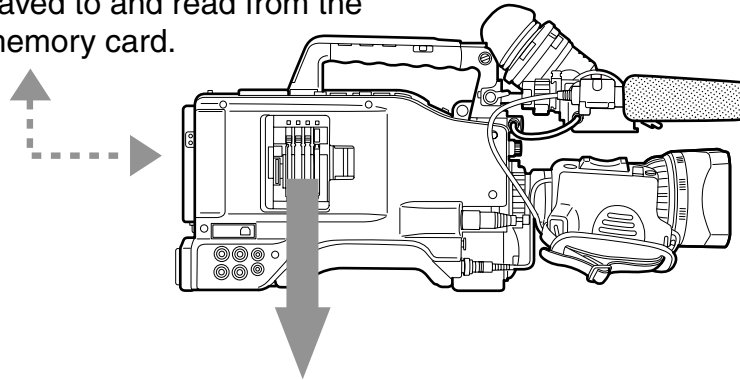

**P2 mode shooting and playback
(Pages 30 and 34)**

P2 card

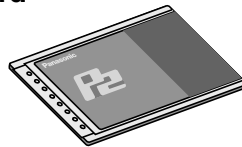

You can use the following features:

- **HD (High Definition) recording**
- **Multi format recording**
- **Variable frame rates**
Slow & quick motion recording
- **Maximum 4 channel uncompressed digital audio recording**

Saving and editing on external devices

Connecting external devices via the USB connector (Page 131)

The data (file) is transferred for nonlinear editing on your computer or other unit.

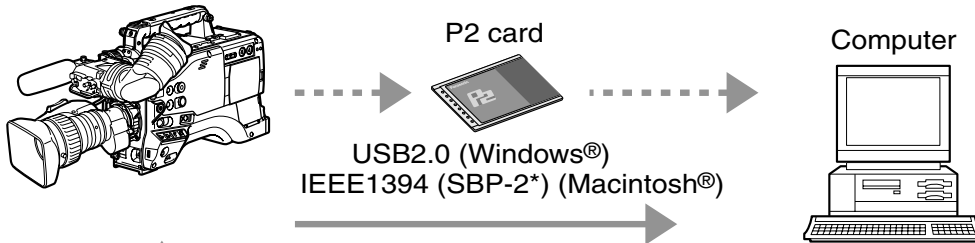

Connecting external devices via the IEEE1394 connector (Page 132)

The unit directly controls the external hard disk drive, and transfers the data (file) to it.

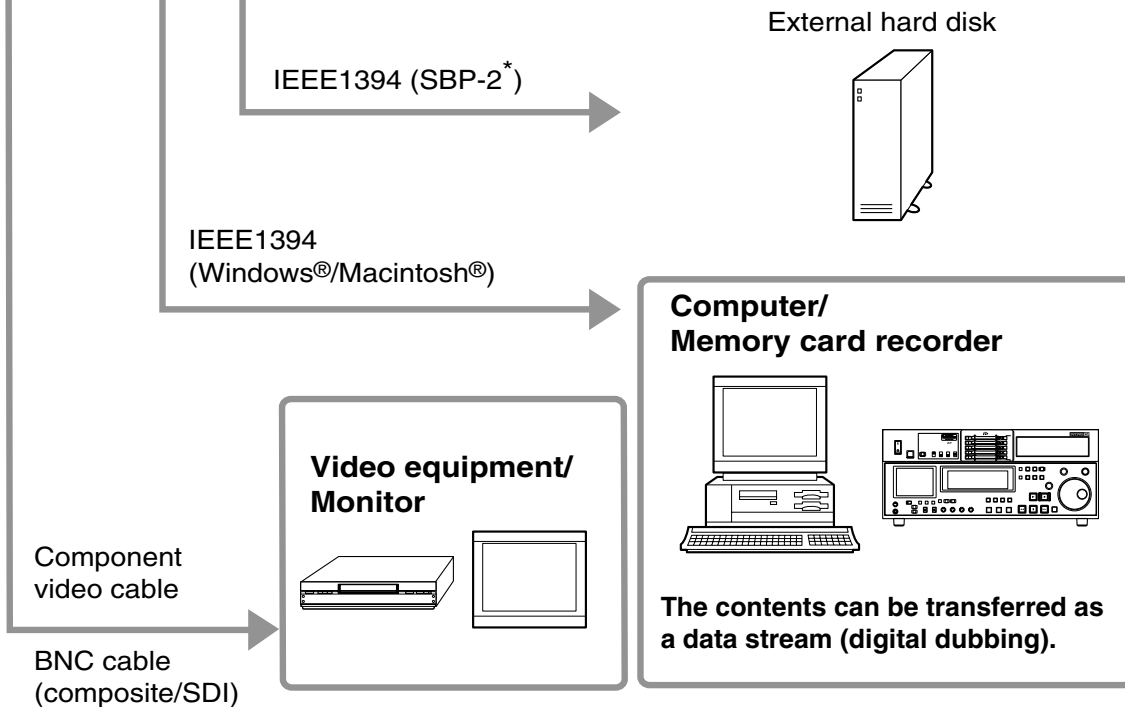

*Serial Bus Protocol-2

System Configuration

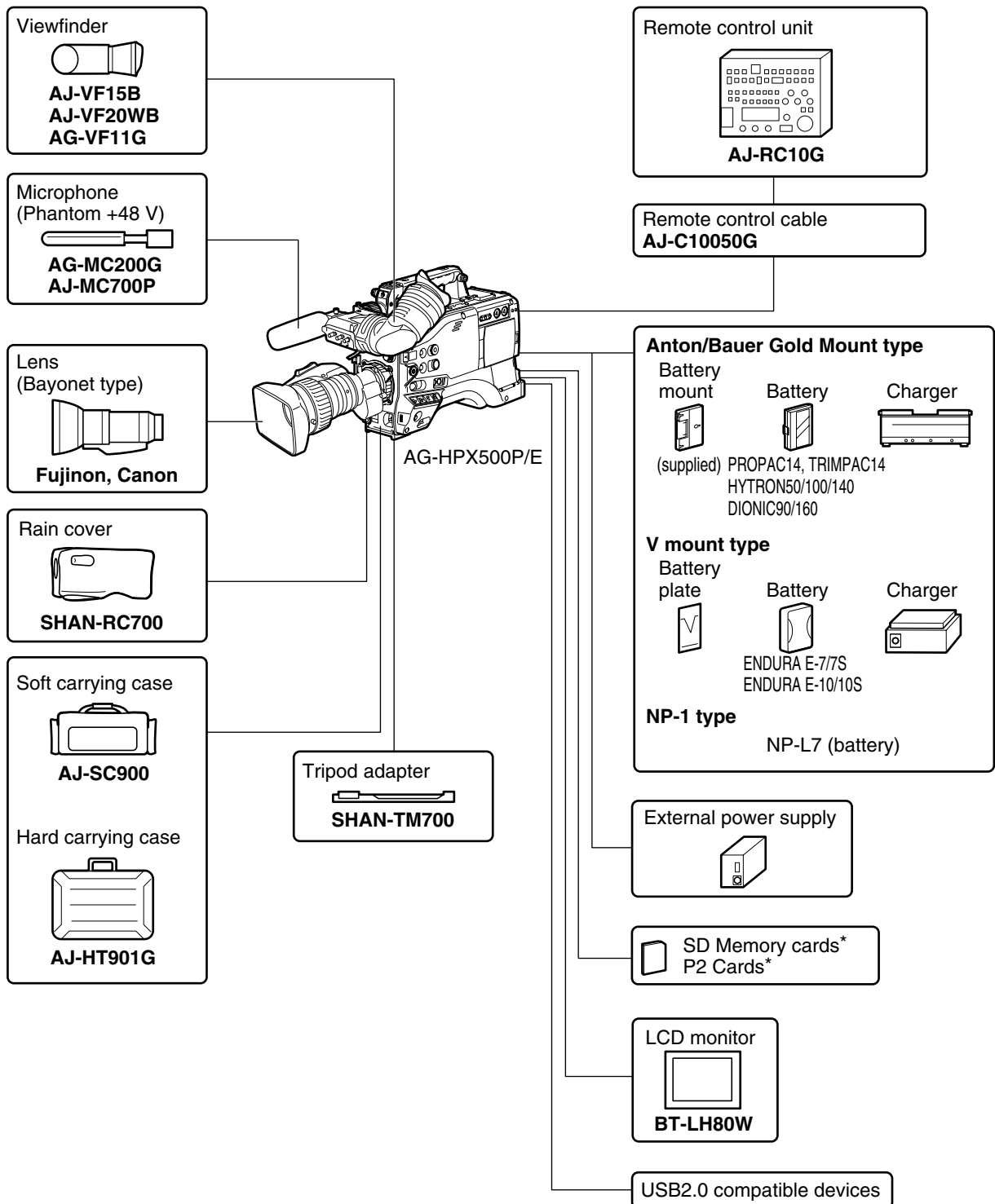

* For the latest information on P2 cards and SD memory cards not available in the operating Instructions, visit the P2 Support Desk at the following Web sites.
<http://pro-av.panasonic.net/>

Power Supply and Accessory Mounting Section

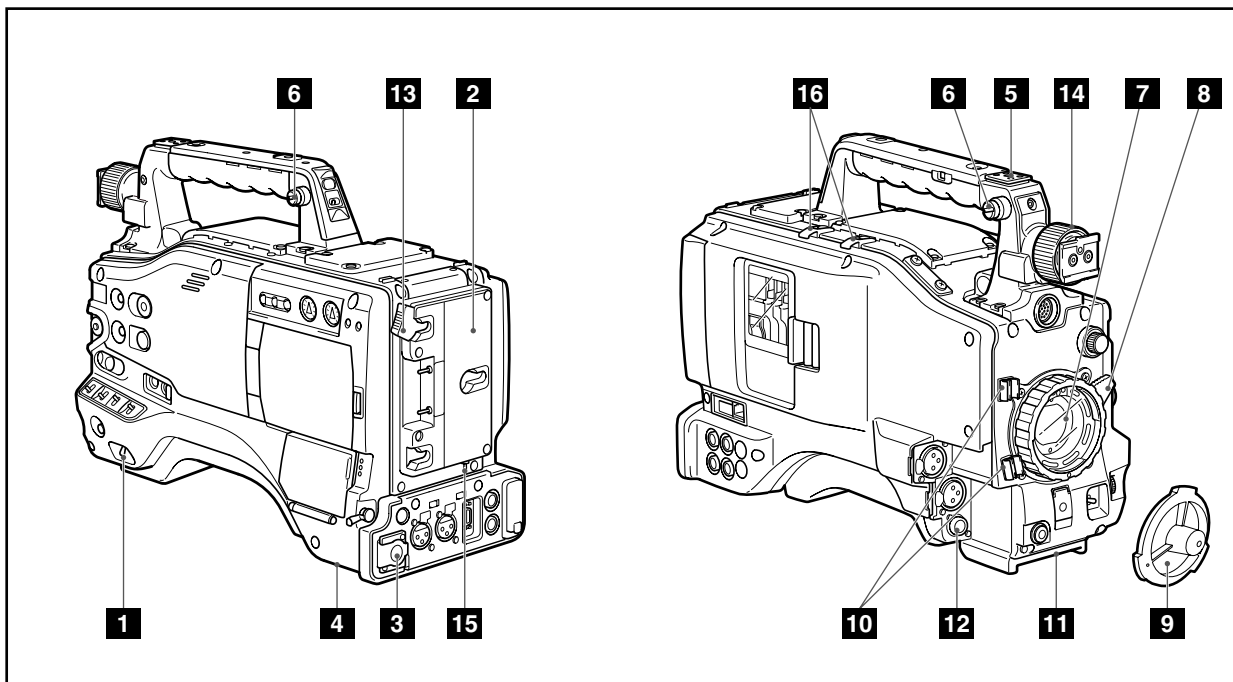
**1 POWER switch**

Used to turn on/off the power.

2 Battery mount

A battery pack from Anton/Bauer is mounted here.

For details, refer to [Mounting the Battery and Setting the Battery Type] (page 84).

3 DC IN (external power input) socket (XLR, 4P)

This unit is connected to an external AC adapter. For details, refer to [Use of the external DC power supply] (page 86).

4 BREAKER switch

When an excessive amount of current is fed through the video camera recorder, due to any abnormal event, the breaker automatically turns off the power in order to protect the device. After the interior of the video camera recorder has been checked and/or repaired, this button must be depressed. If there is no unusual reaction, the unit can be powered-up.

5 Light shoe

A video light or similar accessory can be attached here.

6 Shoulder strap fittings

The shoulder strap is attached here. For details, refer to [Attaching the Shoulder Strap] (page 101).

7 Lens mount (2/3-type bayonet)

The lens is attached here. For details, refer to [Mounting the Lens] (page 91).

8 Lens lever

Tighten this lever to lock the lens to the lens mount.

For details, refer to [Mounting the Lens] (page 91).

9 Lens mount cap

To remove the cap, raise the lens lever. When the lens is not mounted, replace the cap.

10 Lens cable/microphone cable clamp

This clamp secures the lens and microphone cables.

For details, refer to [Mounting the Lens] (page 91).

11 Tripod mount

When you want to mount the AG-HPX500P/E on a tripod, the optional tripod adapter (SHAN-TM700) is attached here.

For details, refer to [Mounting the Camera on a Tripod] (page 100).

12 LENS jack (12-pin)

The lens connection cord is connected here.

For a detailed description of your lens, see the relevant manufacturer's instruction manual.

13 Battery release lever

Pull down the release lever to release the battery pack.

14 Viewfinder left-right positioning ring

For details, see [Adjusting Viewfinder Right-Left Position] (page 88).

15 Light control switch

For details, refer to [Power Supply] (page 84).

16 Cable holder

Used to secure the light cable and microphone cable.

Audio (input) Function Section

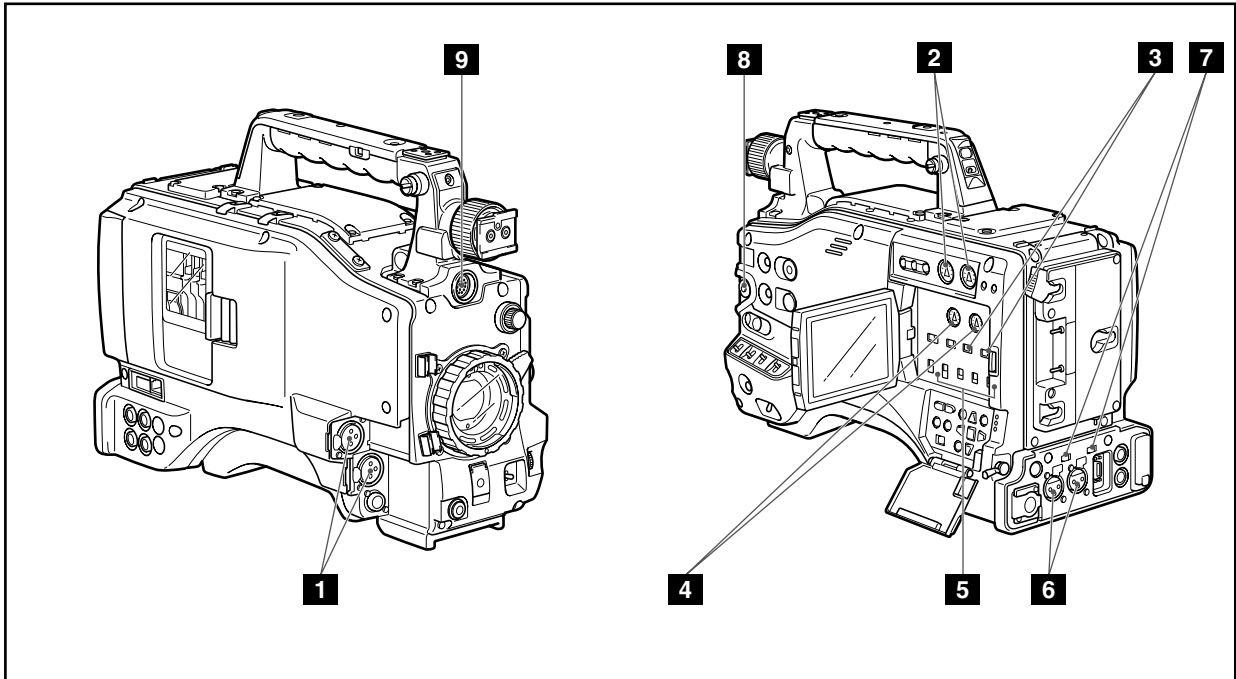

1 MIC IN (microphone input) jacks FRONT1/Front2 (XLR, 3-pin)

- Connect microphones (optional accessories) to these jacks. Power for the microphone comes from this jack.
- A phantom-powered microphone may be connected. To use a phantom-powered microphone, set the menu option F.MIC POWER1/F.MIC POWER2 to ON in the <AUDIO SETUP> screen.

For details, refer to [Preparing for Audio Input] (page 98).

2 AUDIO LEVEL CH1/CH2 (audio channel 1 & 2 recording level adjustment) controls

- With the AUDIO SELECT CH1/CH2 switch positioned to [MAN], these controls can be used to adjust the recording levels for Audio Channels 1/2.
- Note that the controls are designed to be locked. For adjustment, each control must be depressed while turning.

3 AUDIO SELECT CH1/CH2 (audio channel 1 & 2 automatic/manual level adjustment selector) switch

Use this switch to select recording level control mode for Audio Channels 1 and 2.
AUTO: Recording level automatically controlled.
MAN: Recording level manually controlled.

4 AUDIO LEVEL CH3/CH 4 (audio channel 3 & 4 recording level adjustment) controls

Set the menu option AUTO LEVEL CH3/AUTO LEVEL CH4 to OFF in the <AUDIO SETUP> screen to use these controls to adjust the recording level of audio channels 3 and 4.

5 AUDIO IN (audio input selector) switch

Use this switch to select the signals recorded through Audio Channels 1 - 4.

FRONT: Signal from the microphone connected to the MIC IN jack is recorded.

REAR: Signal from the audio device or microphone connected to the REAR 1/ REAR 2 connector is recorded.

CH1	Input	CH2	Input
FRONT1	FRONT1 jack	FRONT	FRONT2 jack
FRONT2	FRONT2 jack	REAR	REAR2 jack
REAR	REAR1 jack	—	—

CH3	Input	CH4	Input
FRONT	FRONT1 jack	FRONT	FRONT2 jack
REAR	REAR1 jack	REAR	REAR2 jack

<Note>

With a front microphone (such as AG-MC200G) connected only to the FRONT2 jack, setting CH1 of the AUDIO IN switch to FRONT2, setting CH2-CH4 to FRONT and setting the MONITOR SELECT CH1/2 / CH3/4 selector switch to CH3/CH4 will result in no sound output to CH3.

6 REAR 1/REAR 2 (audio input channel 1 & 2) connectors (XLR, 3-pin)

Audio devices or a microphone may be connected here.

For details, refer to [When Using Audio Devices] (page 99).

7 LINE/MIC/+48V (line input/mic input/mic input + 48V) selector switch

Used to select the audio signal input from the REAR1/REAR2 connectors.

LINE: Audio signal line-input from the audio device is input.

MIC: Audio signal from a self-powered (active) microphone is input. (The main unit does not supply power to the remote microphone).

+ 48V: Audio signal from a passive microphone is input. (The unit supplies power to the remote microphone).

<Note>

Power is supplied when R.MIC POWER in the <AUDIO SETUP> screen is set to ON.

8 FRONT AUDIO LEVEL (audio recording level adjustment) control

- This control adjusts the recording level of Audio Channels 1 and 2.
- Level adjustment is possible when the AUDIO SELECT switch is set to MAN.
- Use the menu options FRONT VR CH1 and FRONT VR CH2 in the <AUDIO SETUP> screen to select the input connector this control will be used for.

9 Viewfinder connector

For details, refer to [Mounting the Viewfinder] (page 88).

Audio (output) Function Section

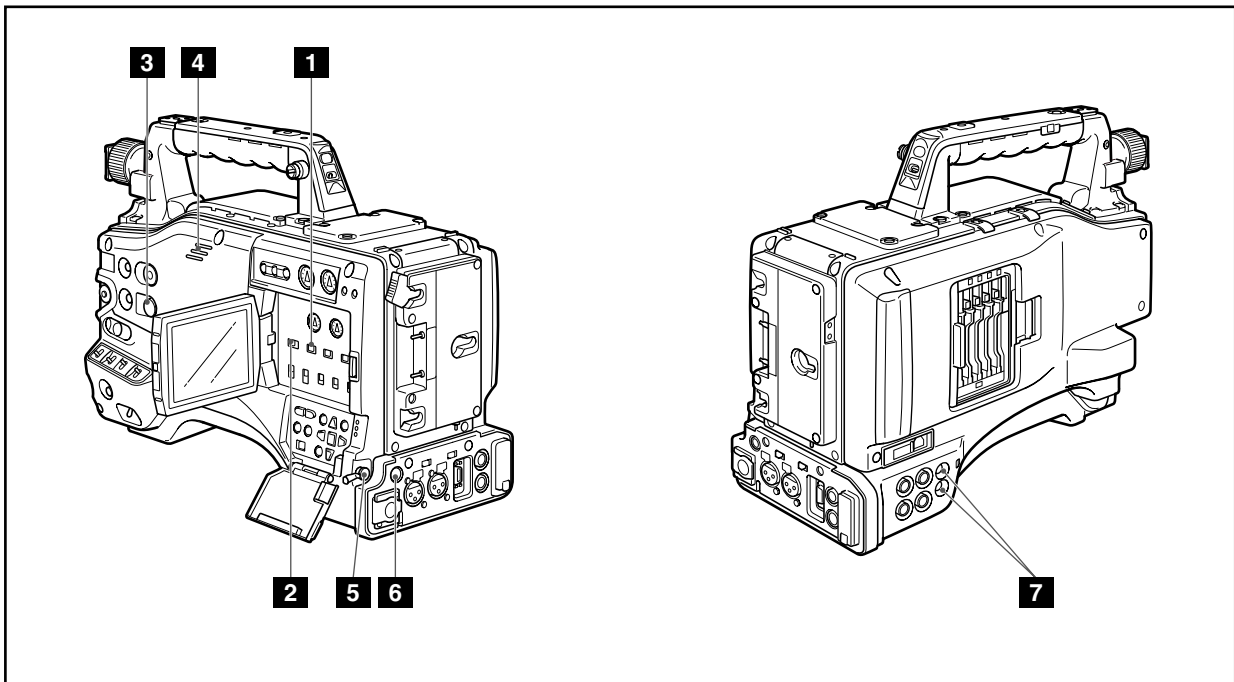

1 MONITOR SELECT (audio channel) CH1/2 / CH3/4 selector switch

Use this switch to select the audio channel whose signals are output to the speakers, earphones or AUDIO OUT connector.

CH1/2: Signals on Audio Channels 1 and 2 are output.

CH3/4: Signals on Audio Channels 3 and 4 are output.

The channel indications on the display window and on the audio level meter in the viewfinder are synchronised with this selector switch.

2 MONITOR SELECT (audio selection) CH1/3 / ST / CH2/4 selector switch

In combination with the MONITOR SELECT CH1/2 / CH3/4 switch, select the audio signal output to the speakers and earphones, and from the AUDIO OUT connector.

MONITOR SELECT (Left)		MONITOR SELECT (Right)	
		CH1/2	CH3/4
MONITOR SELECT	CH1/3	Audio Channel 1	Audio Channel 3
	ST	Stereo signals from Audio Channels 1 and 2	Stereo signals from Audio Channels 3 and 4
	CH2/4	Audio Channel 2	Audio Channel 4

3 MONITOR/ALARM (volume) control

Used to control the volume of sound output from the monitor speakers and earphones.

It also adjusts the alarm sound volume.

4 Speakers

The speakers output EE sound during recording, and reproduced sound during playback. The speakers emit an alarm sound when the warning lamp blinks and/or the indicator activates. EE sound and playback sound are not output during alarm sound output.

When the PHONES jack is connected with earphones, sound from the speaker is automatically muted.

5 PHONES (earphones) jack (mini jack)

This connector is designed for audio monitoring (stereo) earphones. When earphones are connected, sound from the speakers is automatically muted.

6 DC OUT (DC power supply) output socket

This output socket is designed for 12-VDC. It provides a maximum current of 1.5 A.

7 AUDIO OUT connector

- This connector outputs audio signals recorded on Channels 1/2 or 3/4.
- Output signals are selected with the MONITOR SELECT CH1/2 / CH3/4 selector switch.

Shooting and Recording/Playback Functions Section

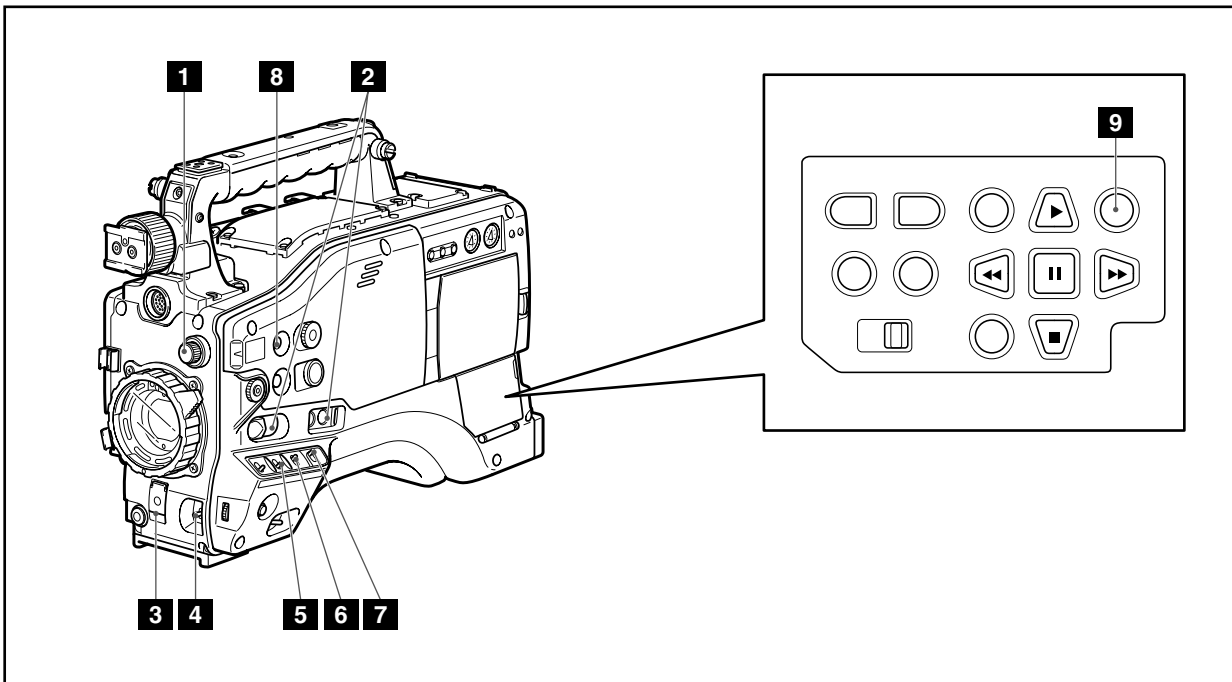

Shooting and Recording (camera unit)

1 ND FILTER (filter switching) control

This control adjusts the amount of light entering the CCD. Use this control in strong outdoor lighting.

Control position	Setting	Description
1	OFF	Do not use the ND filter.
2	1/4	Reduces the amount of light entering the CCD to 1/4.
3	1/16	Reduces the amount of light entering the CCD to 1/16.
4	1/64	Reduces the amount of light entering the CCD to 1/64.

2 USER MAIN, USER 1 and USER 2 buttons

These buttons can be assigned user-selected functions, using a menu option. Each button, when pressed, performs the assigned function. For more information, see [Assigning Functions to USER Buttons] (page 55).

3 SHUTTER switch

Used to enable or disable the electronic shutter.

OFF: Electronic shutter disabled.

ON: Electronic shutter enabled.

SEL: Used to change the speed of the electronic shutter.

This dial switch returns to its original position.

Each turn of the switch alters the shutter speed.

For more information, see [Setting the Electronic Shutter] (page 53).

4 AUTO W/B (white/black) BAL switch

AWB	Automatically adjusts the white balance. Set the WHITE BAL switch on the side to [A] or [B] and use this switch to adjust the white balance, which takes a few seconds. The adjusted value is stored in memory. When the WHITE BAL switch is set to PRST and the color temperature is indicated with the AUTO W/B BAL switch set to AWB, setting the switch to AWB again makes it possible to change the preset color temperature.
ABB	Back balance is automatically adjusted.

For details, refer to [Adjusting the White Balance and Black Balance] (page 50).

5 GAIN selector switch

- This switch adjusts video amplifier gain to suit ambient lighting conditions at the time of the shooting.
- Use the menu options MID GAIN and HIGH GAIN in the <SW MODE> screen to set the M/H position gain values.
- The factory settings for L, M and H are 0 dB, 6 dB, and 12 dB, respectively.

<Note>

The camera is locked to 0 dB gain regardless of GAIN switch position and setting when the FRAME RATE is 22 fps (59.94 Hz) or less than 23 fps (50 Hz).

6 OUTPUT/AUTO KNEE selector switch

This switch selects the video signals sent from the camera unit to the memory card recorder unit, viewfinder and video monitor.

CAM. AUTO KNEE ON	Video being recorded through the camera is output with the AUTO KNEE circuit activated. The compression level (KNEE point) of the video signal is automatically changed according to the received signal.
CAM. AUTO KNEE OFF	Video being recorded through the camera is output with the AUTO KNEE circuit turned off. The KNEE point is locked to the level set in the menu.
BARS	Color bar signals are output with the AUTO KNEE circuit turned off.

■AUTO KNEE function

Usually, when you adjust levels to shoot people or scenery against a strongly lit background, the background will be totally whited-out, with buildings and other objects blurred.

In this case, the AUTO KNEE function reproduces the background clearly.

This function is effective when:

- The subject is a person positioned in the shade under a clear sky.
- The subject is a person inside a car or building, and you also want to capture the background visible through a window.
- The subject is a high-contrast scene.

7 WHITE BAL (white balance memory selector) switch

Used to select the white balance adjustment method.

PRST: Use this when you have no time to adjust the white balance.

- The value for the white balance is factory-set to 3200 K.
- While the setting menu or the color temperature is displayed, turn the AUTO W/B BAL switch to AWB to set the color temperature to 3200K or 5600K.

A • B: Pressing the AUTO W/B BAL Switch toward [AWB] automatically adjusts the white balance, saving the adjusted value in Memory A or B. For more information, see [Adjusting the White Balance] (page 50).

8 DISP/MODE CHK button

- Press this button to turn off the LCD monitor and viewfinder display. (The time code indication stays on.)
- A second press of the button turns the display back on and holding it down displays shooting conditions and functions assigned to USER switches.
- It also serves to turn off the alarm sound.

9 MODE button

- This button toggles between the CAMERA mode and MCR mode at each press.
- Holding down this button for 2 seconds or longer in the MCR mode will engage the PC mode. Since this button does not work in the PC mode, power off the camera to exit the PC mode and switch to another mode. The camera will start up in the CAMERA mode when powered up next time.
- Use the mode LED to check current mode.

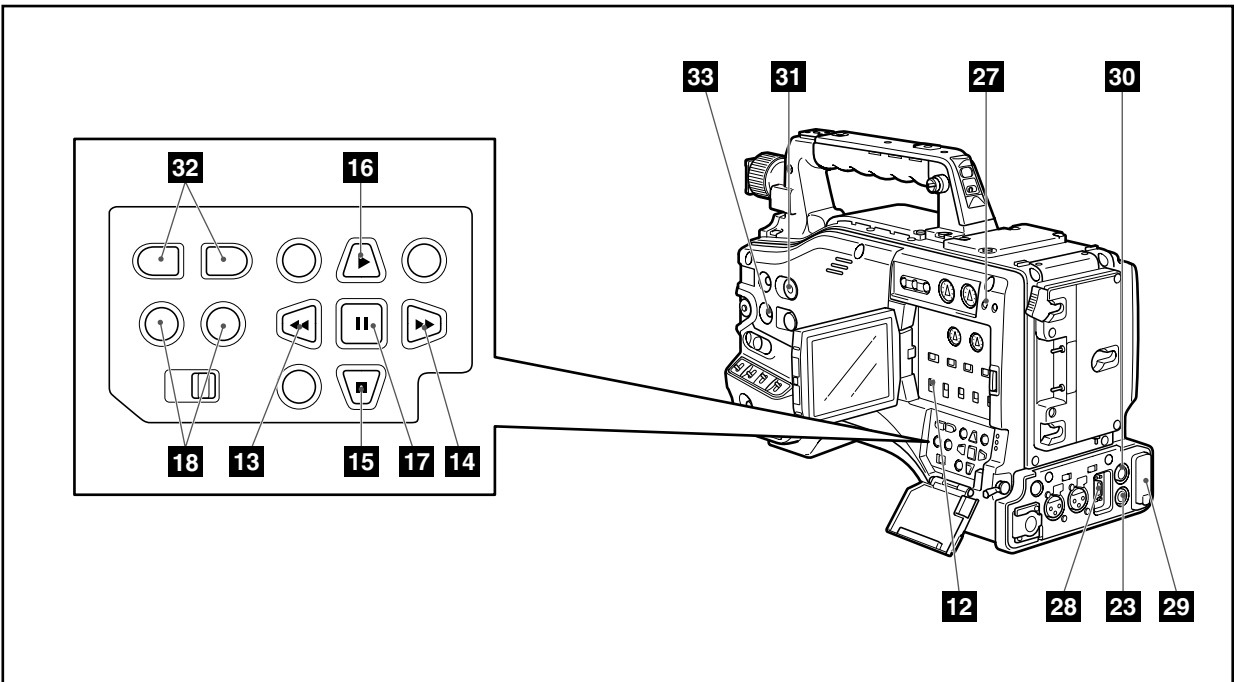
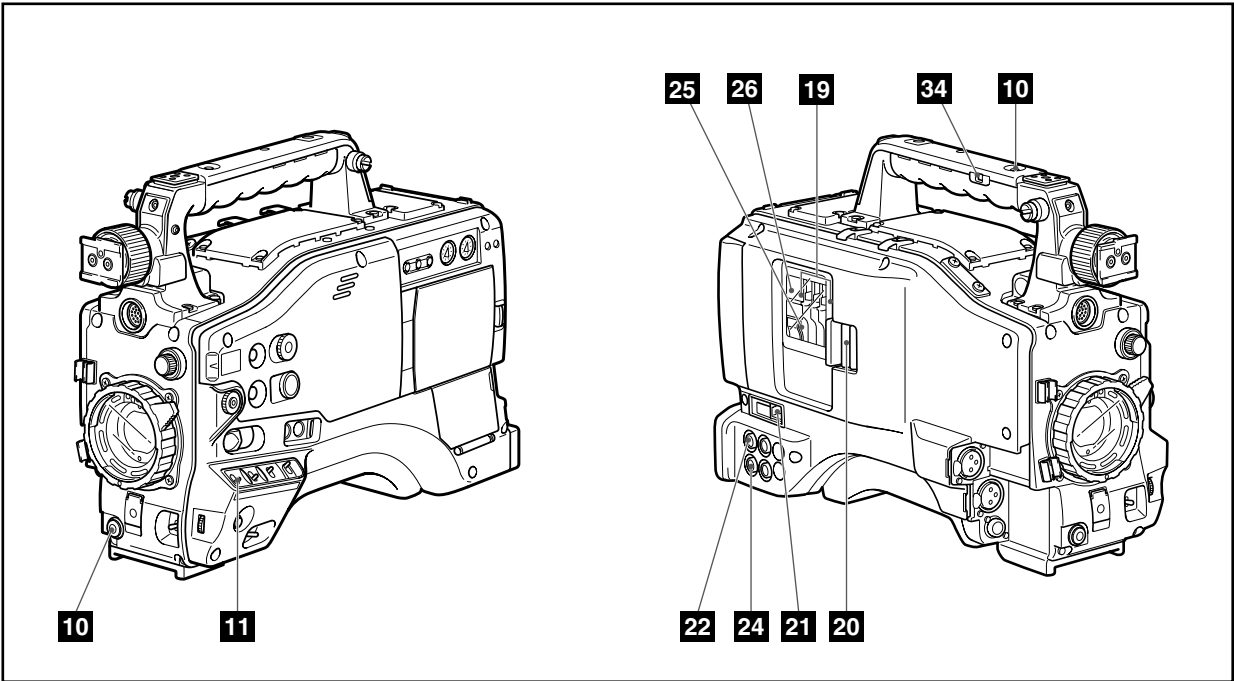

Shooting and Recording/Playback Function Section (recording)

10 REC START/STOP button

Pressing this button starts recording, pressing again stops recording.

This button has the same function as the VTR button at the lens.

When pressed in the MCR mode, the camera automatically switches to the CAMERA mode and starts recording.

11 SAVE switch

This switch selects the power saving mode.

ON: Forcibly turns off the LCD.

OFF: LCD is on.

The operating status display in the viewfinder goes off when the SAVE switch is set to ON. But it remains on during special recording.

12 OUTPUT CHARACTER switch

This switch controls the superimposition of characters onto the video output (VIDEO OUT, COMPONENT OUT and SDI OUT) to indicate status or menus.

ON: Superimposes characters.

OFF: Does not superimpose characters.

13 ◀ REW (fast-reverse) button

During pause, this button performs fast-reverse playback.

During playback, it fast-reverses playback at about 4× normal speed.

If this button is pressed when playback is paused, the beginning of the clip being played is located in pause mode (cue-up mode).

14 ▶▶ FF (fast forward) button

During pause, this button performs fast playback.

During playback, it performs fast playback at about 4× normal speed.

If this button is pressed when playback is paused, the beginning of the next clip is located in pause mode (cue-up mode).

15 ■ STOP button

This button stops playback.

The menu cursor moves in the thumbnail display.

16 ▶ PLAY button

This button is used to view playback using the viewfinder screen or a color video monitor.

17 || STILL (pause) button

Press to pause playback.

18 REC buttons (red and white)

Press the red and white buttons simultaneously to start recording the 1394 input signal and press the STOP button to stop recording.

<Note>

To record 1394 input signals, be sure to set the MCR format to the input signal format before starting recording. Do not change the format or terminate signal input during recording.

19 P2 CARD ACCESS LED

This LED indicates the recording and playback status of each card.

For details, refer to [P2 CARD ACCESS LED and status of P2 cards] (page 32).

20 Slide lock button

Used to open the slide-out door for inserting P2 cards. While depressing this button, slide the door to the left.

21 USB 2.0 connector

Connect a USB 2.0 cable to this connector.

Select USB DEVICE under the menu option PC MODE in the <OTHER FUNCTIONS> screen to send data via the USB 2.0 connector. The camera cannot be used for recording, playback or clip operations when this function is used.

For details, refer to [Connecting to External Devices Using USB2.0 Port (PC mode)] (page 131).

22 GENLOCK IN connector

This connector inputs a reference signal when the camera unit is gen-locked, or when the time code is externally locked.

<Note>

- The reference signal must be a Y signal (1080/60i, 720/60P, 1080/50i or 720/50P) (HD) or a composite signal (480/60i or 576/50i).

- The subcarriers for the down-converter (composite signal) output from the camera-recorder cannot be externally locked.

- GENLOCK cannot be engaged during playback.

23 REMOTE (remote control) connector

By connecting the extension control unit AJ-RC10G (optional accessory), some functions of the camera can be remote-controlled.

For details, refer to [Connecting the AJ-RC10G Extension Controller] (page 102).

24 VIDEO OUT (video signal output) connector

This connector outputs video signals.

- In HD mode, down-converted composite video signals are output.

- Use the DOWNCON MODE in the setup menu DISPLAY SETUP screen to change output. (The factory setting is LETTER BOX.)

<Note>

13 to 18 work only in MCR mode.

25 SD memory card insertion slot

Insert an SD memory card (optional accessory) in this slot. It is used for uploading meta data as well as for reading and writing USER files and SCENE files.

<Note>

■SD memory card precautions

- Use only cards that conform to the SD card standard or the SDHC standard in this camera.

- Multimedia cards (MMC) cannot be used. (Use of such cards may prevent recording.)

- Be sure to use mini SD card adapter only when using mini SD cards. (Note that this camera will not operate normally when a mini SD adapter is installed without also inserting a card. Be sure to insert a card when an adapter is installed.)

- Use of Panasonic SD/SDHC memory cards and mini SD cards is recommended. Be sure to format such cards in this camera.

- This camera supports 8 MB, 16 MB, 32 MB, 64 MB, 128 MB, 256 MB, 512 MB, 1 GB and 2 GB SD memory cards and 4 GB SDHC memory cards.

- For the latest information not available in the Operating Instructions, visit the P2 Support site at the above Web site.

■ About SD and SDHC memory cards

- SD logo is a trademark.
- The SDHC (SD High Capacity) card is a new standard, established by the SD Card Association in 2006, for large-scale memory cards with capacities above 2 GB.
- Multi Media Card (MMC) is a registered trademark of Infineon Technologies AG.

26 **BUSY (operation mode display) lamp**

This lamp indicates the active status of the SD memory card.

It stays illuminated when the card is active.

<Note>

While the lamp is on, do not insert or remove the card.

27 **R-SIDE P2 card access LED**

This LED indicates access status for all four P2 card slots. It blinks when any of the inserted P2 cards is accessed and lights when a card is inserted.

For details, refer to [P2 CARD ACCESS LED and status of P2 cards] (page 32).

28 **COMPONENT OUT connector (D4 connector)**

- This connector outputs component video signals.
- Use the menu option CMPNT/SDI SEL in the setting menu <OUTPUT SEL> screen to select AUTO, 1080i, 480i, or 576i. This connector does not support up-conversion.

29 **1394 connector**

- Connect an IEEE1394 cable to this connector.
- Select 1394 DEVICE or 1394 HOST under the menu option PC MODE in the <OTHER FUNCTIONS> screen to send data via the 1394 connector.

For details, refer to [Connecting to External Devices Using the IEEE1394 Connector (PC mode)] (page 132).

30 **SDI OUT connector**

- This connector outputs SDI signals.
- Use the menu option CMPNT/SDI SEL in the setting menu <OUTPUT SEL> screen to select AUTO, 1080i, 480i, or 576i. This connector does not support up-conversion.

31 **SCENE FILE dial**

This dial allows you to load and set the shooting conditions for a scene file already recorded with the conditions corresponding to the dial position.

<Note>

During recording, selecting a position with a different frame rate will not change the frame rate until the camera is set to recording standby mode.

For details, refer to [How to Use Scene File Data] (page 79).

32 **PAGE/VAR button**

- In the thumbnail display, press this button to turn pages.
- During variable speed playback press this button to change playback speed and in still mode, press to start frame-by-frame playback.

33 **FOCUS ASSIST button**

This button turns focus assist on and off.

Turning on the focus assist function displays a frequency distribution graph in the top right corner of the viewfinder and LCD display.

Turn the focus ring on the lens to place the graph further to the right.

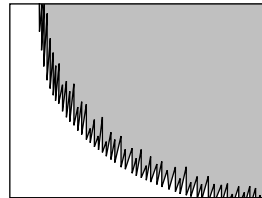

When the image is out of focus

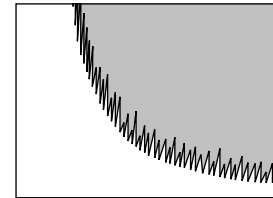

The white area moves to the right as the image comes into focus.

34 **Recording enable/disable switch**

This switch enables/disables the REC START/STOP button on the handle.

ON: Enables the REC START/STOP button.

OFF: Disables the REC START/STOP button.

Menu/Thumbnail Operation Section

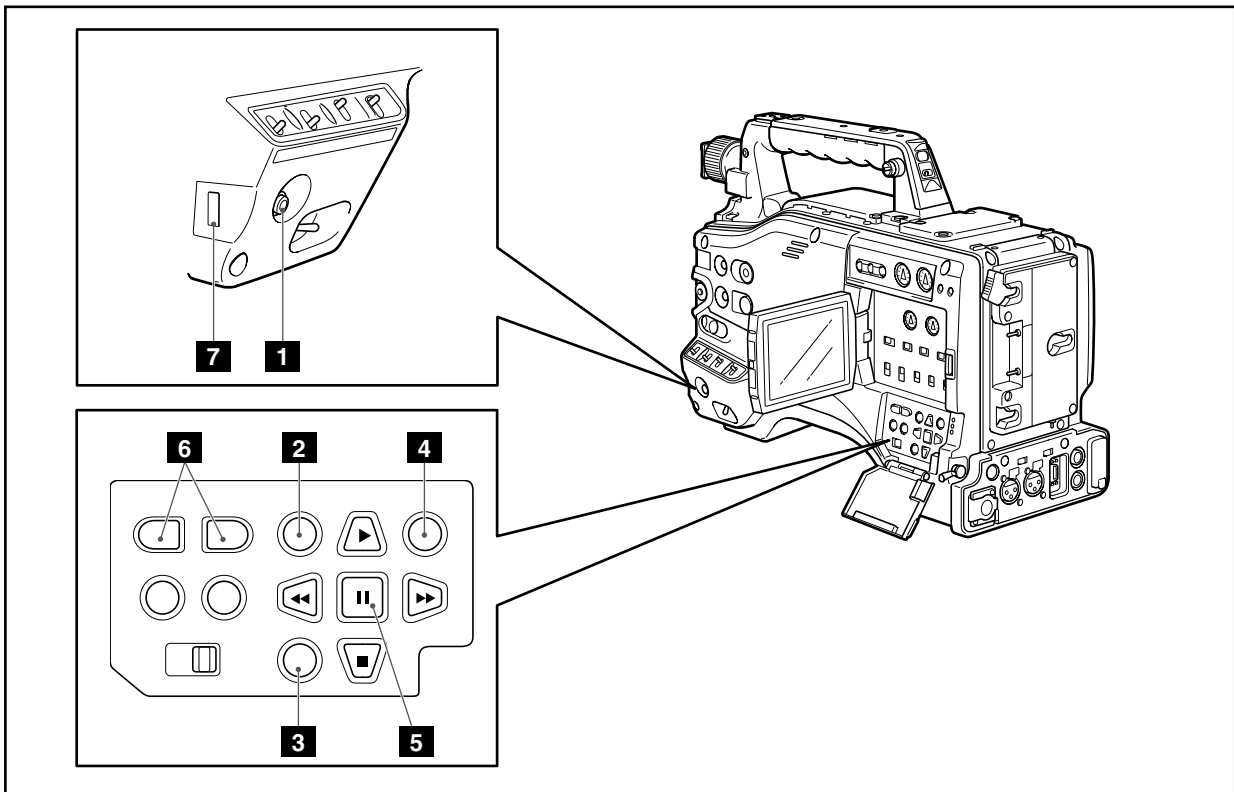

1 MENU button

- Press and hold this button to display the setting menu and press it again to return to the previous image.
- This button is not available in the thumbnail display.

<NOTE>

Use the **SET** button or the **JOG dial** button to go between menus and select items. For details, see section [Viewfinder and LCD menus] (page 116).

2 Thumbnail button

In MCR mode, press this button to switch between the thumbnail screen and 1394 input mode. Note that this switchover is not performed during recording or playback.

3 Thumbnail menu button

In thumbnail display mode, use this button to access thumbnail menu functions to delete clips, for example.

<Note>

Use the **CURSOR** and **SET** buttons to select thumbnails and access menu functions. For details, see [Manipulating Clips with Thumbnails] (page 103).

4 MODE button

This button toggles between the CAMERA mode and MCR mode. For details, see [Shooting and Recording/Playback Function Section] (page 19).

5 CURSOR and SET buttons

Use these buttons to manipulate menus, the menu bar and thumbnails.

The four triangular buttons are CURSOR buttons and the square center button is the SET button.

6 PAGE/VAR button

Pressing this button during thumbnail display scrolls thumbnail pages forwards and backwards in page units.

7 JOG dial button

- Use this button to go between menu pages and to select and set items in open setting menus (camera menu or MCR menu).
- In a setting menu, turning the JOG dial downwards moves the menu cursor downwards and turning it upwards moves the menu cursor upwards.
Press the JOG dial button to confirm made settings.

Time Code Section

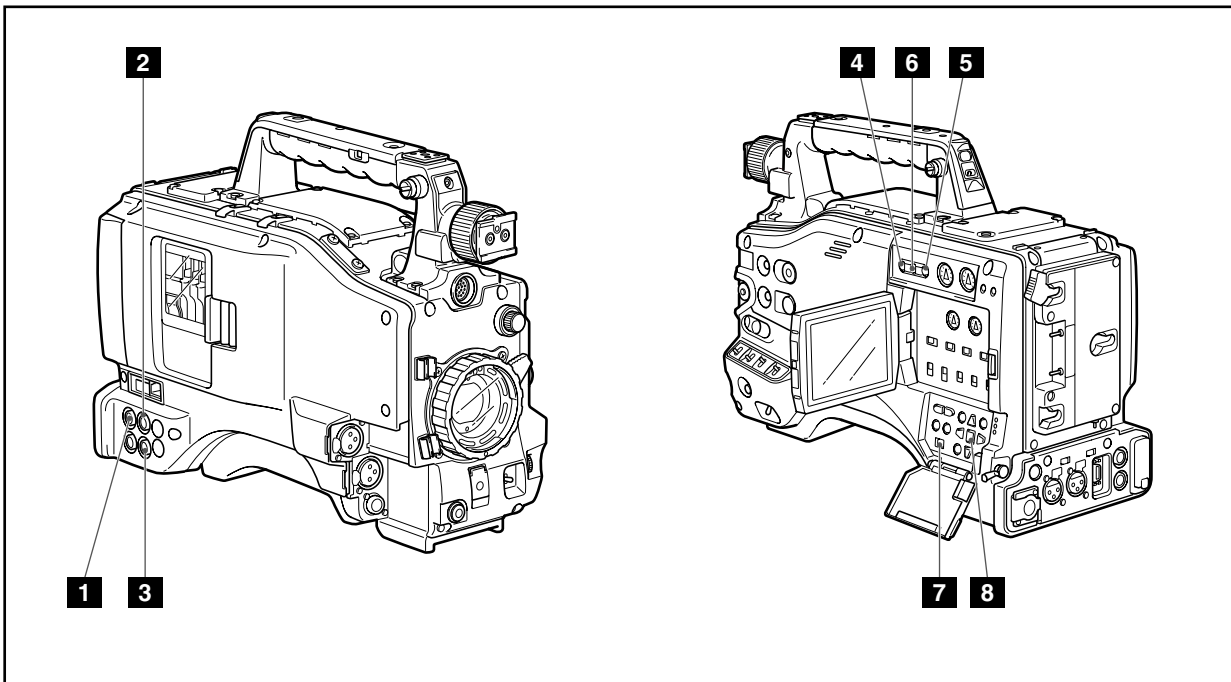

1 GENLOCK IN connector (BNC)

This connector is used to input a reference signal before the camera unit is gen-locked, or before the time code is externally locked. For details, refer to [Externally Locking the Time Code] (page 64).

2 TC IN connector (BNC)

This connector is used to input a reference time code when you externally lock the time code. For details, refer to [Externally Locking the Time Code] (page 64).

3 TC OUT connector (BNC)

When you inter-lock the time code of the AG-HPX500P/E with that of an external device this must be connected with the time code input (TC IN) connector of the external device. For details, refer to [Outputting the time code externally] (page 65).

4 HOLD button

Pressing this button freezes the time data indication on the counter. Note that time code generation continues. Pressing the button again reactivates the counter. This function is used to ascertain the time code or CTL count of a particular recorded scene.

5 RESET button

Use this button to reset the counter value on the time code display to 0:00:00. When the TCG switch is positioned at [SET] and the setting menus TC PRESET screen and UB PRESET screen are open, press this button to reset all set values to 0 and press the SET button to preset.

6 COUNTER (counter display selector) button

The LCD monitor and the viewfinder show the counter value, time code, user bit and frame rate data.

7 TCG (time code selector) switch

This switch is used to specify the stepping mode for the built-in time code generator.

F-RUN	Select this position to continuously advance the time code independently of the P2 card recording status. Use this mode to synchronise the time code with the time of day, or to externally lock the time code.
SET	Select this position to set the time code and/or user bits.
R-RUN	Select this position to advance the time code only during recording. The time code is continuously recorded during normal recording. But deleting clips and continuing recording of clips at a frame rate of 24P or 24PA that have been recorded at any other frame rate may break the sequence of time code recording.

<Note>

Always use the CURSOR and SET buttons to set the time code and user bits. The JOG dial button cannot be used for this purpose.

8 CURSOR and SET buttons

Use these buttons to set the time code and user bits.

The four triangular buttons are the CURSOR buttons, and the center rectangular one is the SET button.

For guidance in setting the time code and user bits, see [Setting Time Data] (page 58).

Warning and Status Display Functions

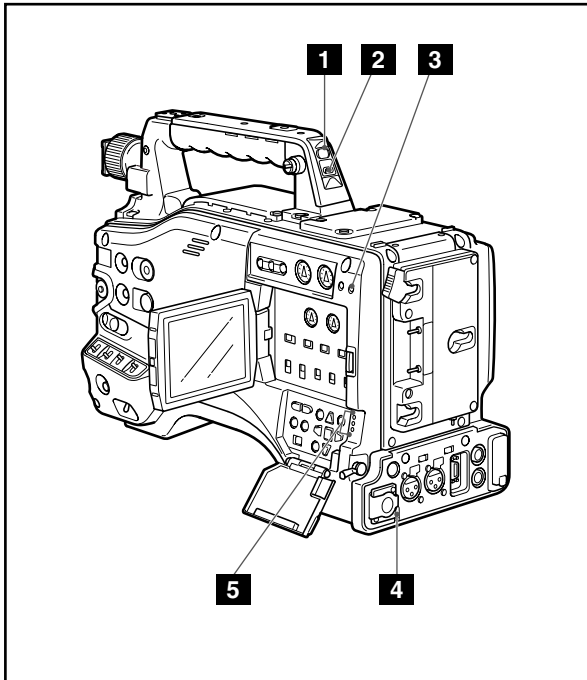

1 Back tally lamp

When the BACK TALLY switch is set to [ON], the lamp behaves in the same way as the front tally lamp at the viewfinder.

2 BACK TALLY switch

This switch controls the action of the back and rear tally lamps.

ON: Back and rear tally lamps enabled.

OFF: Back and rear tally lamps disabled.

3 WARNING lamp

This lamp starts blinking or lights up if something unusual occurs in the memory.

4 Rear tally lamp

When the BACK TALLY switch is set on [ON], the rear tally lamp behaves in the same way as the back tally lamp.

5 Mode LED

Shows the camera unit mode.

CAM: Lights red in CAMERA mode.

MCR: Lights green in MCR mode.

PC: Lights orange in PC mode.

LCD Monitor

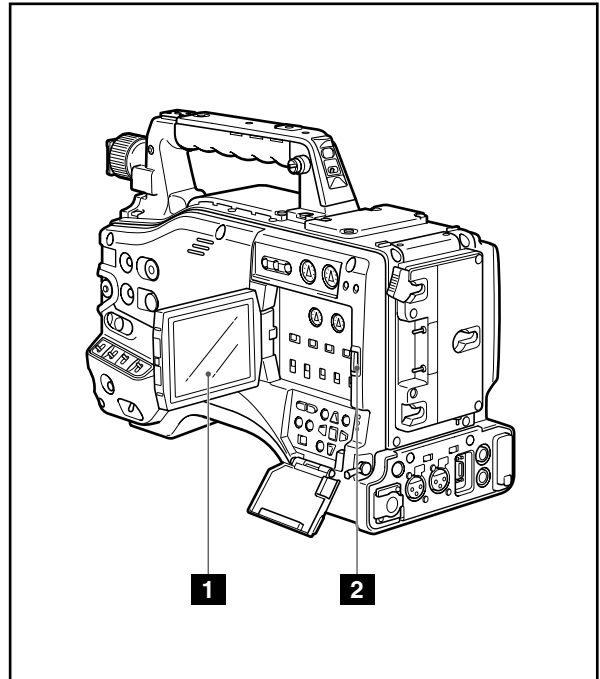

1 LCD monitor

The LCD monitor displays the video in the viewfinder.

Alternatively, it can show clips on the P2 card in a thumbnail format.

In thumbnail display mode, you can use the thumbnail menu buttons, CURSOR and SET buttons to manipulate or delete clips, or format P2 cards.

For details, refer to [Adjusting and setting the LCD monitor] (page 75).

2 OPEN button

Used to open the LCD monitor.

Viewfinder

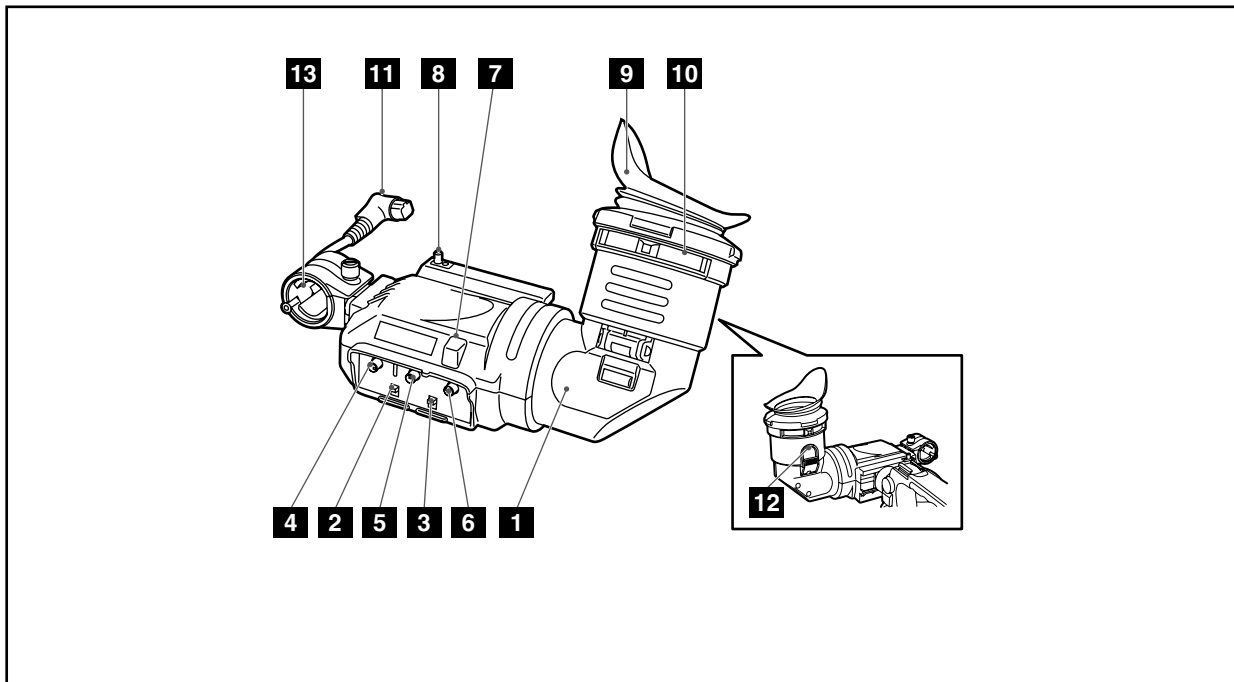

1 Viewfinder (supplied accessory)

During recording or playback, the viewfinder displays the video image in monochrome. It also displays warnings, messages, zebra patterns, markers (safety zone and center markers), etc.

2 ZEBRA (zebra pattern) switch

This switch is used to display the zebra pattern in the viewfinder.

ON: Zebra pattern displayed.

OFF: No zebra pattern displayed.

3 TALLY switch

Used to control the front tally lamp.

ON: Tally lamp goes on.

OFF: Tally lamp goes out.

4 PEAKING control

Used to adjust the outlines of the video image in the viewfinder for easier focusing. Recorded video and output camera signals are not affected.

5 CONTRAST control

Used to adjust the contrast of the video image in the viewfinder. Recorded video and output camera signals are not affected.

6 BRIGHT control

Used to adjust the brightness of the video image in the viewfinder. Recorded video and output camera signals are not affected.

7 Front tally lamp

This lamp goes on during recording when the TALLY switch is set to [ON]. It also blinks in synchronisation with the REC lamp in the viewfinder, and provides alerts.

8 Viewfinder securing screw

Used to attach or remove the viewfinder.

9 Eyepiece

10 Diopter adjustment ring

Use this to make adjustments in line with your diopter, in order to obtain optimum clarity in the viewfinder image.

11 Connecting plug

12 Locking button

13 Microphone holder

Setting Date and Time of Internal Clock

The CLOCK SET value is recorded in the contents (clip), and affects the sequence of playback of the thumbnails. Before carrying out recording, be sure to check and set CLOCK SET and TIME ZONE.

- This shows you how to adjust the calendar to 5:20 PM on December 25, 2007.

- 1** Set the POWER switch to ON.
- 2** Press the MENU button.
- 3** Use the JOG dial button to select setting menu OTHER FUNCTIONS, then press the JOG dial button to open the OTHER FUNCTIONS screen.
For details on menu operation, refer to [Using the menus] (page 116).
- 4** Use the JOG dial button to select TIME ZONE, then press the JOG dial button.
- 5** Turn the JOG dial button to set the time difference from Greenwich Mean Time.
 - Check what time zone you are in and set accordingly.

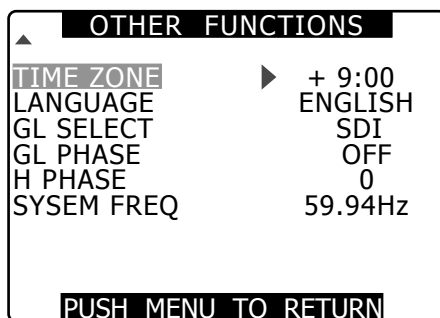

Time zone

Time difference	Area	Time difference	Area
00:00	Greenwich	-00:30	
-01:00	Azores Islands	-01:30	
-02:00	Mid-Atlantic	-02:30	
-03:00	Buenos Aires	-03:30	Newfoundland Island
-04:00	Halifax	-04:30	
-05:00	New York	-05:30	
-06:00	Chicago	-06:30	
-07:00	Denver	-07:30	
-08:00	Los Angeles	-08:30	
-09:00	Alaska	-09:30	Marquesas Islands
-10:00	Hawaii	-10:30	
-11:00	Midway Island	-11:30	
-12:00	Kwajalein	+11:30	Norfolk Island
+13:00		+10:30	Lord Howe Island
+12:00	New Zealand	+09:30	Darwin
+11:00	Solomon Islands	+08:30	
+10:00	Guam	+07:30	
+09:00	Tokyo	+06:30	Rangoon
+08:00	Beijing	+05:30	Bombay
+07:00	Bangkok	+04:30	Kabul
+06:00	Dacca	+03:30	Tehran
+05:00	Islamabad	+02:30	
+04:00	Abu Dhabi	+01:30	
+03:00	Moscow	+00:30	
+02:00	Eastern Europe	+12:45	Chatham Islands
+01:00	Central Europe		

<NOTE>

- The clock is accurate to within about ±30 seconds a month with the power turned off.
- Check and set the time when accurate time is required. After setting the time, change the setting menu TIME ZONE item and the display and the recorded local time will be reset accordingly.

- 6** Select YES at the CLOCK SET item in OTHER FUNCTIONS, then press the JOG dial button.

- The CLOCK SET screen appears.

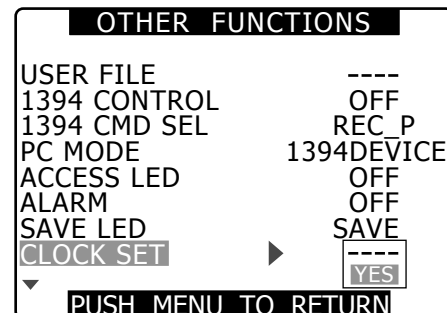

- 7** Turn the JOG dial button to select **YEAR**, then press the JOG dial button.

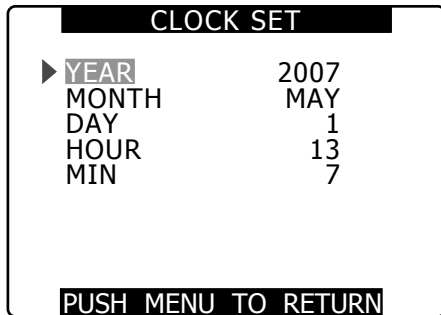

- 8** Turn the JOG dial button to set **YEAR** to **2007**, then press the JOG dial button.
- A year between 2000 to 2030 can be set.

- 9** Turn the JOG dial button to select **MONTH**, then press the JOG dial button.

- 10** Turn the JOG dial button to set **MONTH** to **DEC**, then press the JOG dial button.

- 11** Set **DAY**, **HOUR** and **MIN** in the same way as setting **YEAR** and **MONTH**.
- This is a 24-hour clock.

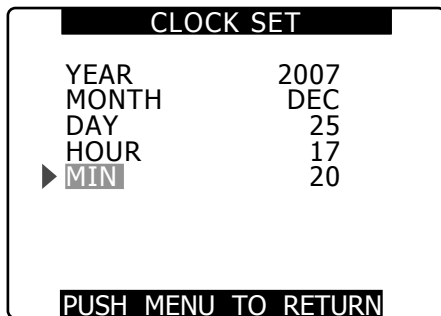

P2 Cards

Inserting P2 Cards

<Note>

When using the camera recorder for the first time, be sure to set the time data beforehand. On how the time data is set, see [Setting Date and Time of Internal Clock] (page 28).

- 1 Turn on the POWER switch.
- 2 While pressing the slide lock button, move the slide-out door to the left.
 - The door opens.

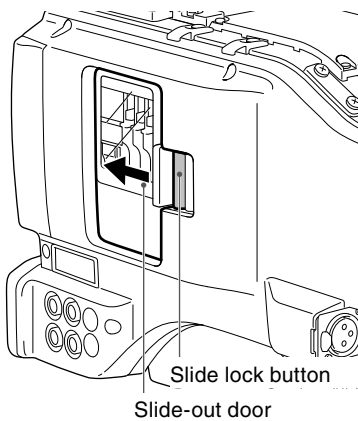

- 3 Insert a P2 card in a P2 card slot.
 - Press in the card until the eject button pops up.

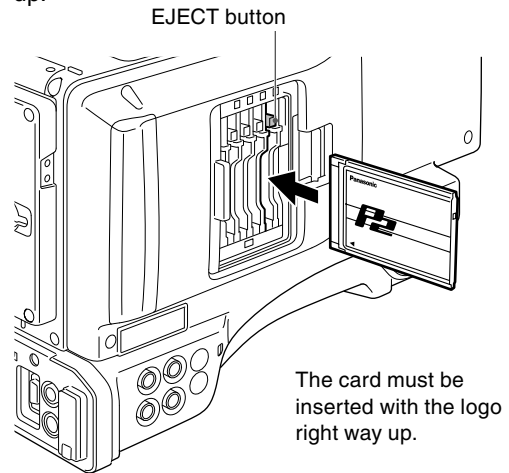

- 4 Tilt up the popped-up EJECT button.

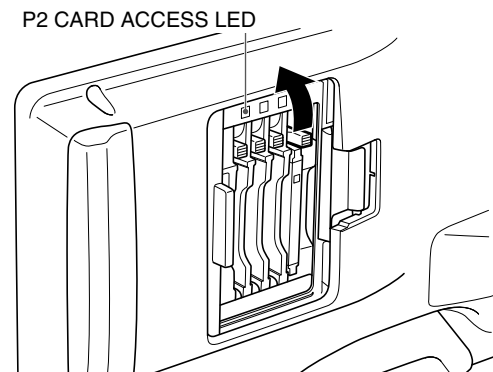

- Insert a P2 card into the AG-HPX500P/E. The P2 CARD ACCESS LED for the appropriate slot indicates the status of the P2 card. For how the P2 card status is indicated, see [P2 CARD ACCESS LED and status of P2 cards] (page 32).

5 Close the slide-out door.

<Note>

- To prevent cards from falling out, dust from entering and reduce the risk of exposure to static electricity, do not move the AG-HPX500P/E with the slide-out door open.
- Format P2 cards on a P2 device or on a PC using P2 Viewer software.

Removing P2 Cards

1 While pressing the slide lock button, move the slide-out door to the left.

2 Tilt down the EJECT button.

3 Then depress the eject button to release the P2 card.

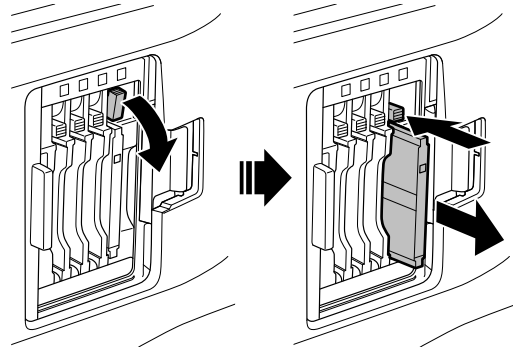

Tilt down the EJECT button.

Depress the tilted-down EJECT button to release the P2 card.

<Note>

- When a P2 card is being accessed or it is being recognised after insertion (P2 CARD ACCESS LED blinks in orange), do not remove the P2 card. Removing a P2 card during access could damage it.
- If a P2 card being accessed is removed, the viewfinder displays “TURN POWER OFF” and the AG-HPX500P/E gives a warning using an alarm and the WARNING LED. In addition, all P2 CARD ACCESS LEDs blink rapidly in orange. If this is the case, turn the power off. For more information on warning indications, see [Warning System] (page 142).
- Removing a P2 card during access may corrupt clip data. Check the clips and restore them if required. For more information about how to restore clips, see [Restoring Clips] (page 108).
- If a P2 card being formatted is removed, it may not be formatted properly. In this case, the viewfinder displays “TURN POWER OFF”. If this message appears, turn off the power, then restart the AG-HPX500P/E to reformat the card.
- If a P2 card is inserted while another P2 card is being played back, the inserted P2 card is not recognised and the P2 CARD ACCESS LED for that card does not come on. Card recognition starts when the playback ends.
- A P2 card inserted in an empty slot during recording may not be immediately recognized during the following events.
 - Immediately following PRE REC operation
 - Immediately before or after a recording that bridges P2 cards in two slots (hot swap recording, etc.)
- The P2 CARD ACCESS LED can be set to stay off in the setup menus, OTHER FUNCTIONS screen, ACCESS LED. When the camera is used in this way, remove cards when the camera has been powered down or a sufficiently long time after terminating recording, playback and other operating modes.
- Removing a P2 card during thumbnail display terminates the thumbnail display.
- A P2 card inserted in an empty slot during interval recording or one-shot recording is not recognized and cannot be used in the recording. The card will be recognized when the recording is completed.

To Prevent Accidental Erasure of P2 Card Content

To prevent the content of a P2 card being accidentally erased, position the write-protect switch on the P2 card at [Protect].

<Note>

Write-protect switchover can be performed while the card is being accessed (during recording or playback), but does not take effect until access to the card ceases.

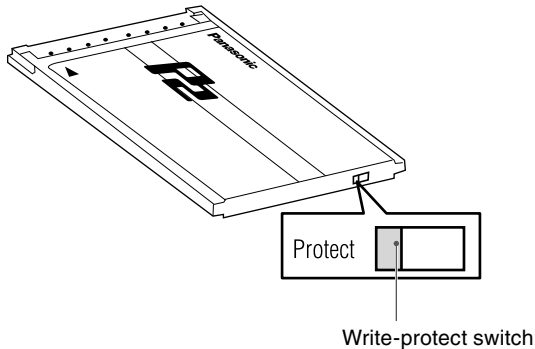

P2 CARD ACCESS LED and status of P2 cards

P2 CARD ACCESS LED	Status of P2 Card	
Stays on in green	Recording enabled	Writing and reading enabled.
Stays on in orange	Selected for recording	Writing and reading enabled for current recording mode (loop, interval or one-shot recording).
Blinks in orange	Being accessed	Writing or reading being performed.
Quickly blinks in orange	Being recognized	The P2 card is being recognised.
Blinks in green	Card full	The P2 card has no free space. Only reading is enabled.
	Write-protected	The write-protect switch on the P2 card is positioned at [PROTECT]. Only reading is enabled.
Stays off	Card not supported	The card is not supported by your AG-HPX500P/E. Replace the card.
	Incorrect format	The P2 card is not properly formatted. Reformat the card.
	Card not inserted	No P2 card is inserted. Card recognition standby.

<Note>

The ACCESS LED in the LCD monitor blinks when any of the cards in slots 1 to 4 is being recorded or read, and lights to indicate that the camera is ready to record. The ACCESS LED is off when none of the inserted P2 cards is available for recording.

P2 card recording times

Model number	AJ-P2 C004HG	AJ-P2 C008HG	AJ-P2 C016RG
Capacity	4GB	8GB	16GB
DVCPRO HD*	Approx. 4 min.	Approx. 8 min.	Approx. 16 min.
DVCPRO HD 720P/24PN	Approx. 10 min.	Approx. 20 min.	Approx. 40 min.
DVCPRO HD 720P/30PN 720P/25PN	Approx. 8 min.	Approx. 16 min.	Approx. 32 min.
DVCPRO50 Audio 4CH	Approx. 8 min.	Approx. 16 min.	Approx. 32 min.
DVCPRO/DV Audio 2CH	Approx. 16 min.	Approx. 32 min.	Approx. 64 min.

* DVCPRO HD excludes 720P/30PN, 720P/24PN and 720P/25PN.

- This camera cannot use AJ-P2C002SG (2 GB) cards.
- The indicated capacities include a management area so the total area available for recording is somewhat smaller.

Splitting clips recorded on P2 cards

This camera will automatically generate additional clips for a continuous recording on an 8 GB or higher capacity P2 card when the recording exceeds the durations given below. Even so, a P2 device will handle such clips as a single clip in thumbnail operations (display, delete, recover, copy, etc.). Such recordings may be handled as separate clips by nonlinear editing software or a PC.

Recording format	Recording time
DVCPRO HD*	Approx. 5 min.
DVCPRO50	Approx. 10 min.
DVCPRO/DV	Approx. 20 min.

* DVCPRO HD excludes 720P/30PN, 720P/24PN and 720P/25PN.

- Use of cards other than the above may require updating the camera driver. For details, see [Updating Camera Drivers] (page 144).
- For the latest information not available in the Operating Instructions, visit the P2 Support Desk at the following Web site.
<http://pro-av.panasonic.net/>

Handling P2 Card Recording

The P2 card is a semiconductor memory card designed for the DVCPRO P2 series, Panasonic's line of professional video and broadcast equipment.

- The DVCPRO P2 format records data as files, making it ideal for computer processing and compatibility. A proprietary format is used for the structure of these files, where in addition to video and audio data recorded in MXF format, various relevant metadata is recorded in the folder structure shown below.

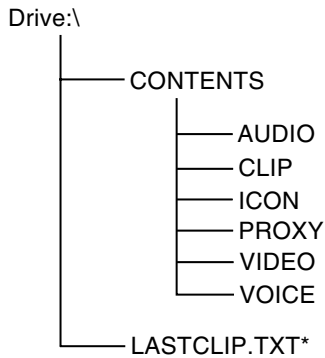

All these folders are required.

* This file contains the last clip data recorded on a P2 device.

<Note>

If any of this data is changed or lost, it will not be recognized as P2 data or the P2 card may no longer be possible to use in a P2 device.

- In order to prevent any of the information from being lost when transferring the data on a P2 card to a personal computer or writing the data stored in a personal computer onto a P2 card, be absolutely sure to download the dedicated software, “P2 viewer” or “P2 content management software” from the following web site and use it for this purpose. (For supporting OS, refer to the following web site as well.)
<http://pro-av.panasonic.net/>
- Follow the steps below to use general software such as Microsoft Windows Explorer or Apple Finder to transfer the data to a PC. Be sure to use P2 Viewer to write data back to a P2 card.
 - Treat the CONTENTS folder and the LASTCLIP.TXT file as a unit.
 - Do not modify the data below the CONTENTS folder.
 - In copying, be sure to copy both the CONTENTS folder and the LASTCLIP.TXT file together.
 - When transferring data from multiple P2 cards, create separate folders for each P2 card to prevent overwriting clips with identical names.
 - Do not delete data on a P2 card.
 - Format P2 cards only on a P2 card device.

Basic Procedures

This section describes the basic procedure for shooting and recording. Before you embark on a shoot, pre-inspect your system to ensure that it works properly. For directions on inspecting your memory card camera-recorder, see [Inspections Before Shooting] (page 137).

Battery Set-up to P2 card Insertion

1 Insert a charged battery pack.

2 Turn the **POWER** switch to **ON** to check the battery remaining level in the **viewfinder**.

- When battery capacity is low, replace it with a fully charged battery.

<Note>

When low battery capacity is indicated after replacing a battery with a fully charged battery, check battery installation.

3 Insert a P2 card and ensure that the **P2 CARD ACCESS LED** stays on in orange or green. Then, close the slide-out door.

- When more than one P2 card slot contains a P2 card, the card in the slot with the lowest number is used first. However, regardless of slot number, a P2 card inserted later will not be accessed until the other cards have been used.

Example: If all four slots contain P2 cards, the cards are used in order of slot numbers 1→2→3→4. However, if the P2 card in Slot 1 is removed and then re-inserted, the cards will be used in the following order: 2→3→4→1.

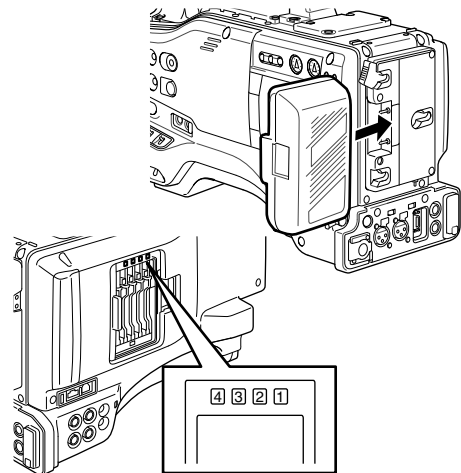

Note that the recording order is retained even if the power is turned off. When the power is next turned on, the last card written before powering-down will be the target card.

Setting the switches before shooting and recording

When a battery and P2 cards are installed, set the switches as detailed below, before starting to use your AG-HPX500P/E.

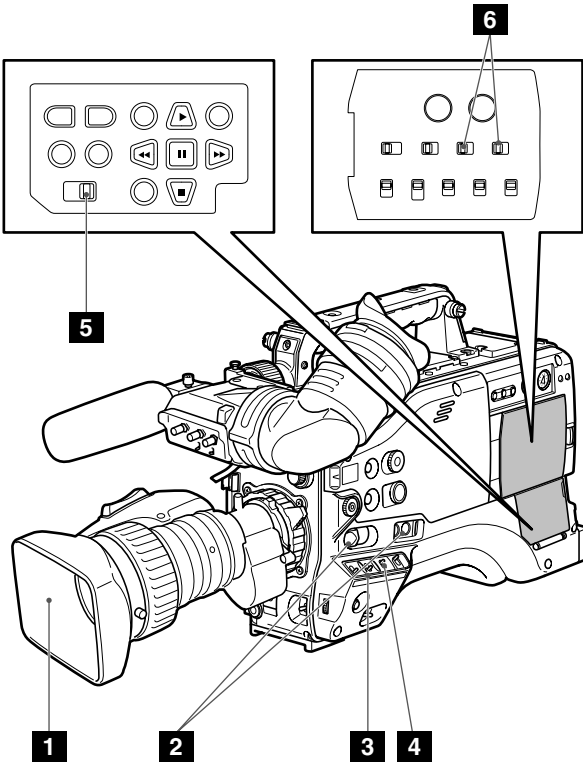

- 1 Iris**
The iris is automatically adjusted when the lens is set to the auto iris mode.
- 2 USER MAIN/USER1/USER2**
Assigning the SLOT SEL function to a USER button allows you to select a P2 card among multiple P2 cards for recording. The P2 card selected for recording switches with each press of the USER button, and the P2 CARD ACCESS LED of the selected P2 card lights orange. The slot number of the card to be recorded appears in green in the LCD monitor and the viewfinder.
For more information on viewfinder displays, see [Viewfinder Status Indication Layout] (page 67).
- 3 GAIN switch**
Normally, this should be set to L (0 dB). If conditions are too dark, an appropriate gain level should be set.
- 4 AUTO KNEE selector switch**
Set to ON or OFF. Turning OFF the AUTO KNEE selector switch allows you to select one of three settings in the setting menu SCENE FILE.
- 5 TCG**
Set to F-RUN or R-RUN.
- 6 AUDIO SELECT CH 1/CH 2**
Set to AUTO.

<Note>

- The slot selected for recording cannot be changed when recording has started.
- Use the USER MAIN/USER1/USER2 item in setting menu SW MODE screen to assign functions to the USER MAIN/USER1/USER2 button.

Shooting

White/Black Balance Adjustment to Recording Completion

For shooting, follow the steps below.

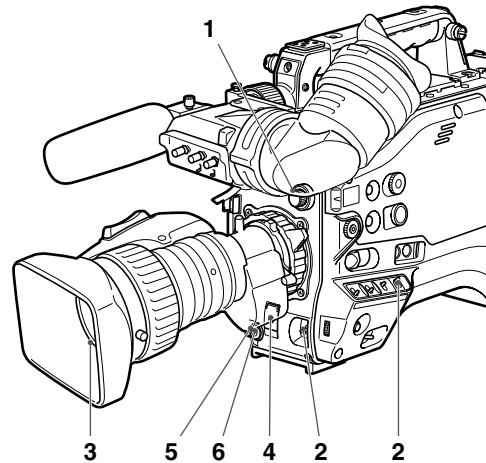

- 1 Use the ND FILTER control to select a filter according to light conditions.**
- 2**
 - **When the white balance is saved:**
 - Position the WHITE BAL switch to [A] or [B].
 - **When the white or black balance is not saved and you have no time to adjust the white balance:**
 - Position the WHITE BAL switch to [PRST].
 - The color temperature can be set to 3200K or 5600K.
 - **If the white balance is adjusted on the spot:**
 - Select a filter according to light conditions. Then, position the WHITE BAL switch to [A] or [B] and shoot a white test subject so that it appears at the center of the screen. Then, follow the steps below to adjust the white balance.
 1. Turn the AUTO W/B BAL switch toward [AWB] to adjust the white balance.
 2. Turn the AUTO W/B BAL switch toward [ABB] to adjust the black balance.
 3. Turn the AUTO W/B BAL switch toward [AWB] to adjust the white balance again.
 For directions on making adjustments, see [Adjusting the White Balance] (page 50) and [Adjusting the Black Balance] (page 51).
- 3 Point the camera at your subject to adjust the focus, and zoom.**

4 To use the electronic shutter, set the shutter speed and shutter mode.

For more information, see [Setting the Electronic Shutter] (page 53).

5 Press the REC START/STOP button to start recording.

- During recording, the REC lamp in the viewfinder stays illuminated.

6 To stop recording, press the REC START/STOP button.

- The REC lamp in the viewfinder goes out.

<Note>

■ Operation Buttons

In CAMERA mode, all operation buttons (REW, FF, PLAY, STILL, STOP) are disabled.

Normal Recording

- Pressing the REC START/STOP button starts recording of video and sound on the P2 card.
- The video and audio (including additional information) recorded in one session is referred to as a clip.

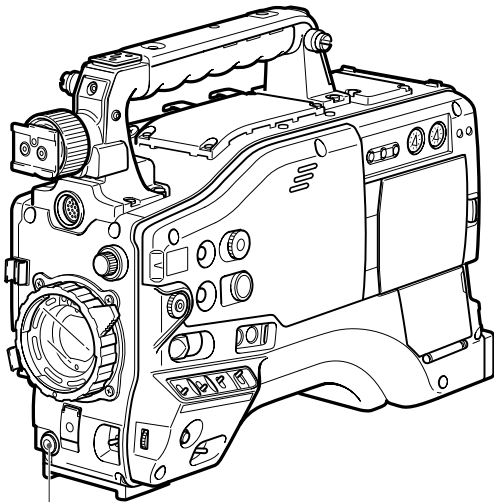

REC START/STOP button

<Note>

Pressing the REC START/STOP button will not immediately stop data write operations to a P2 card in the following situations. And the REC START/STOP button operation is not recognized.

- When terminating a short recording
- When terminating a recording that has just continued onto a second P2 card

Variable Frame Rate (VFR) Recording

This camera takes full advantage of P2 card characteristics by providing frame skipping (undercranking) recording and high-speed (overcranking) recording without the use of a frame rate converter. (The camera must be set to 30PN, 25PN or 24PN to use these functions.) Since the camera records only the effective frames (native recording), recording time is 2 to 2.5 times longer than in the 24P, 30P and 60P modes (25P or 50P at 50 Hz) (standard recording). Like VARICAM (the AJ-HDC27 series), it also provides a recording format that can accommodate the frame rate conversion required for nonlinear editing. (The camera must be set to 30P, 25P or 24P).

<Note>

Variable frame rate (VFR) recording is available only in the 720P mode.

24PN mode:

The camera recorder shoots in the 24 fps native mode. The video signals delivering images at a rate of 24 fps are recorded in 24 frames. The signals are recorded only in the effective frames so recording is possible for 2.5 times as long.

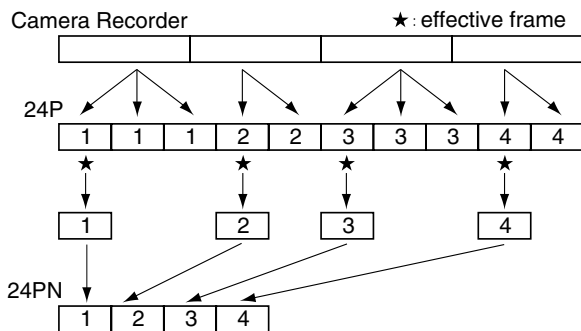

- Before Variable Frame Rate (VFR) shooting, you must set the recording frame rate and the recording format.
- You cannot change the frame rates while recording.

- You can select any of 11 recording frame rates ranging from 12 frames per second (fps) to 60 fps. See [Video and Recording Formats] (page 45).
- There may be slight discrepancies between the recording frame rate displayed and the frame rate at which the images are actually recorded. Refer to the table below.

59.94 Hz		50 Hz	
Recording frame rate displayed	Frame rate at which images are actually recorded	Recording frame rate displayed	Frame rate at which images are actually recorded
60	59.94	50	50.00
48	48.17	48	48.08
36	35.68	37	36.75
32	32.11	32	32.14
30	29.97	30	29.76
26	26.44	27	27.17
24	23.98	25	25.00
22	22.48	23	23.15
20	19.55	20	19.74
18	17.98	18	17.86
12	12.26	12	12.50

Native recording

- 1 Select the 720P/30PN or 720P/24PN (720P/25PN at 50 Hz) recording format in the REC FORMAT item in the RECORDING SETUP screen.**
For details on menu operation, refer to [Using the menus] (page 116).

- 2 Select the appropriate scene file using the SCENE FILE dial.**
 - If necessary, before doing this, perform the camera settings from the setting menu, and register the scene file.
See [Saving scene files and other settings on SD memory cards] (page 82).

- 3 Using the OPERATION TYPE function on the SCENE FILE screen, select FILM CAM, and set the desired recording frame rate using the FRAME RATE function.**
For details on menu operation, refer to [Using the menus] (page 116).

- 4 Press the REC START/STOP button.**
- Pressing the REC START/STOP button starts native recording in the VFR mode.

- No signals are output from the 1394 terminal during recording or recording standby in the native mode.
- Sound is not recorded. However, sound will be recorded when the same frame rate is used for both recording and playback.
- When a recorded clip lasting a long time is to be played back and imported using a nonlinear editing system that supports Varicams, the UB MODE option on the RECORDING SETUP screen must be set to FRM.RATE.

Standard recording

- 1 Select the 720P/60P, 720P/30P, or 720P/24P (720P/50P, or 720P/25P at 50 Hz) recording format in the REC FORMAT item in the RECORDING SETUP screen.**

For details on menu operation, refer to [Using the menus] (page 116).

- 2 Select the appropriate scene file using the SCENE FILE dial.**

- If necessary, before doing this, perform the camera settings from the setting menu, and register the scene file.

- 3 Using the OPERATION TYPE function on the SCENE FILE screen, select FILM CAM, and set the desired recording frame rate using the FRAME RATE function.**

For details on menu operation, refer to [Using the menus] (page 116).

- When the 720P/30P, 720P/24P, or 720P/25P recording is selected, the following indications appear depending on the settings made in the FRAME RATE item in the SCENE FILE screen.

- ① PULL DOWN information displayed in PROPERTY-CLIP PROPERTY-VIDEO
- With the default setting: 2:2 or 2:3
 - With any other settings: other

- ② Format information in the bottom left of the screen when thumbnails are displayed

- With the default setting: 720P/30P, 720P/24P, 720P/25P
- With any other settings: 720P/60P or 720P/50P

(The default setting is 30FRAME at a recording frame rate of 30P and 24FRAME (25FRAME at 25P) at a recording frame rate of 24P.)

- 4 Press the REC START/STOP button.**
- Pressing the REC START/STOP button starts standard recording in the VFR mode, the sound is also recorded.

<Note>

- In the case of a nonlinear editing system that supports Varicams equipped with an effective frame extraction function, you can upload even undercrank or overcrank shooting materials as is. (The UB MODE option on the RECORDING SETUP screen must be set to FRM.RATE.)
- The 24P format is used for 2:3 pull-down recording and the 30P (25P at 50 Hz) is used for 2:2 pull-down recording.

Using variable frame rates (VFR)

Standard speed shooting for making commercials and dramas

When producing commercials and dramas to be shown on a TV screen, as in the case of HDTV/ SDTV and other broadcasts, a frame rate of 24 fps (frames per second) is the norm (1x speed).

If you use the settings below, the same kind of playback as when the programs are broadcast can be obtained. 720P progressive mode and cine-like gamma produce video that looks like it was shot on a film camera.

Recording format (REC FORMAT)	Recording frame rate (FRAME RATE)
720P/24P (2:3 pull-down)	24 fps
720P/24PN (native recording)	

Shooting at standard speed for producing commercials and TV programs

Production aimed at HDTV and SDTV broadcasts for TV audiences must use the full frame rate (x1) of 30 fps (30 frames/sec.) (25 fps at 50 Hz). Use the following settings to obtain the playback speed used for broadcasts. This permits film-like video recording of commercials and music clips that also provide a frame rate suitable for broadcasting.

Recording format (REC FORMAT)	Recording frame rate (FRAME RATE)
59.94 Hz	30 fps
720P/30P (2:2 pull-down)	
	25 fps
720P/30PN (native recording)	
50 Hz	25 fps
720P/25P (2:2 pull-down)	
	25 fps
720P/25PN (native recording)	

Undercrank shooting

This way of shooting provides quick motion effects used to present such scenes as the movement of clouds, someone standing among crowd of people, and moves made by martial artists. If, for instance, you have shot scenes using the 24P recording format for specifying the playback frames, you can double the speed of the quick motion effects by setting the VFR recording frame rate to 12 fps.

Recording format (REC FORMAT)	Recording frame rate (FRAME RATE)
720P/24P, 720P/24PN	Set to 22 fps or lower.
720P/30P, 720P/30PN	Set to 26 fps or lower.
720P/25P, 720P/25PN	Set to 23 fps or lower.

- The 720P/24P, 720P/30P and 720P/25P formats provide a quick motion effect when processed using a nonlinear editing system.

Overcrank shooting

This way of shooting provides slow motion effects used to show car chases as well as action scenes, climax scenes and other dramatic presentations. If, for instance, you have shot scenes using the 30P recording format for specifying the playback frames, you can obtain slow motion effects with the speed halved by setting the recording frame rate to 60 fps. Images in the 720P progressive format will create smoothly flowing slow motion sequences with a high picture quality.

Recording format (REC FORMAT)	Recording frame rate (FRAME RATE)
720P/24P, 720P/24PN	Set to 26 fps or higher.
720P/30P, 720P/30PN	Set to 32 fps or higher.
720P/25P, 720P/25PN	Set to 27 fps or higher.

- The 720P/24P, 720P/30P and 720P/25P formats provide a slow motion effect when processed using a nonlinear editing system.

Shooting in the 1080i/480i Progressive Mode

Selecting 30P, 24P or 24PA (1080i or 480i mode) in the REC FORMAT in the setting menu RECORDING SETUP screen enables shooting in the progressive mode.

■30P mode

This mode enables shooting 30 fps video in the progressive mode. The 30 fps video signal is converted to a 60-field interlaced signal for output and recording.

- This guarantees high-quality video output.

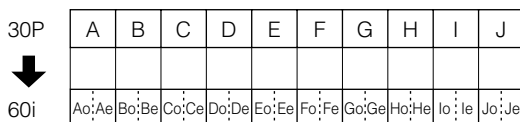

■24P mode

This mode enables shooting 24 fps video in the progressive mode. A 2:3 conversion format is used to convert the 24 fps video signal to a 60-field interlaced signal for output and recording.

- This guarantees a cine-like video output.

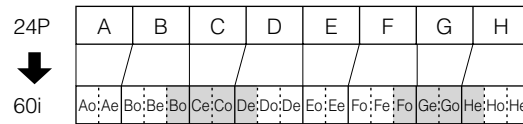

■24P advance mode

This mode enables shooting 24 fps video in the progressive mode.

- The advance mode converts a 24 fps video signal to a 60-field interlaced signal for output and recording.

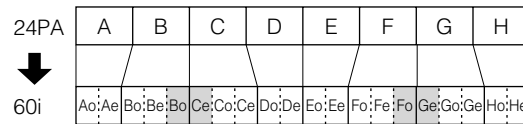

- As shown in the illustration, the conventional 24P (2:3) conversion system for editing extends the BoCe, CoDe, FoGe and GoHe frames into adjacent frames, which causes a drop in picture quality.
- By contrast, the 24P advance conversion system drops the BoCe and FoGe fields to produce video of higher quality. Using an editing system that is compatible with advanced conversion will help to produce better video quality than the normal 24P mode.
- Use the normal 24P mode when working with other editing systems.

<Note>

The following applies to shooting in the progressive mode.

- A gain of 18 dB cannot be used.
- Set the shutter speed to 1/50 (OFF) or to 1/60.
- There may be a slight delay at the start of recording when shooting in the 24P or 24P advance mode because 5 frames are recorded at a time.

Special Recording Modes

During P2 card recording, setting items in the menu option RECORDING SETUP screen provides the following special recording modes: pre-recording, interval recording, one-shot recording, and loop recording.

These recording modes are available only with the following settings.

- OPERATION TYPE item:
 - VIDEO CAM
- Recording format:
 - They are available at 1080i/60i (50i), 1080i/30P (25P), 720P/60P (50P), 720P/30P (25P), or in SD at 60i (50i), 30P (25P).

Pre-recording (PRE REC)

This function is used to start recording a certain number of seconds (approx. 3 seconds for HD recordings or approx. 7 seconds for SD recordings) before actual recording starts.

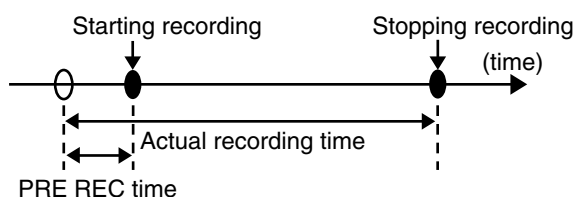

- 1 Check that the OPERATION TYPE item in the menu option SCENE FILE screen and REC FORMAT item in the menu option RECORDING SETUP screen are set as described below.

For details on menu operation, refer to [Using the menus] (page 116).

- OPERATION TYPE item:
 - VIDEO CAM
- Recording format:
 - They are available at 1080i/60i (50i), 1080i/30P (25P), 720P/60P (50P), 720P/30P (25P), or in SD at 60i (50i), 30P (25P).

- 2 Select ON in the PREREC MODE item in the menu option RECORDING SETUP screen.

- 3 Press the REC START/STOP button.

This setting will record audio and video a time period prior to start of recording.

- The following recording modes will disable the pre-recording function and start respective recording function when selected.
 - Recording of video input via the IEEE1394 connector
 - When changing recording formats
 - After a change from playback to recording
 - During interval recording
 - During one-shot recording
 - During loop recording
- Audio and video recording for the pre-recording time interval stated above may not be possible when recording is started immediately after the following changes in operating mode: after a changeover from MCR mode to CAMERA mode, after power-on, and after a change in the PREREC MODE item.

Interval recording (INTERVAL REC)

This function is used to record 1 frame (1/30 s) at the time interval set in the INTERVAL TIME item.

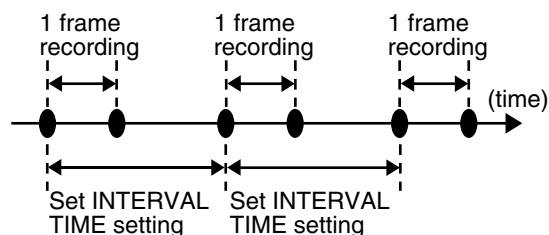

- 1 Check that the OPERATION TYPE item in the menu option SCENE FILE screen and REC FORMAT item in the menu option RECORDING SETUP screen are set as described below.

For details on menu operation, refer to [Using the menus] (page 116).

- OPERATION TYPE item:
 - VIDEO CAM
- Recording format:
 - They are available at 1080i/60i (50i), 1080i/30P (25P), 720P/60P (50P), 720P/30P (25P), or in SD at 60i (50i), 30P (25P).

2 Select **INTERVAL** in the **REC FUNCTION** item in the menu option **RECORDING SETUP** screen.

3 Set the time in the **INTERVAL TIME** item in the menu option **RECORDING SETUP** screen.

4 Press the **REC START/STOP** button.

- The camera will repeat 1-frame recording for the time interval set in the **INTERVAL TIME** item.
- Press the **STOP** button to stop recording.
- To cancel this function, turn the camera off or select **NORMAL** in the **REC FUNCTION** item.
- The following indications appear to the left of the operation status display.
 - During recording: "I-REC" stays lit.
 - During a pause: "I-PAUSE" stays lit.
- When a setting of less than 2 seconds is made in step 3, "I-REC" blinks according to time setting during recording.
- When stopped: "I-" in "I-PAUSE" blinks.

<Note>

- The pre-recording function is not available.
- Sound is not recorded.
- Data recorded (until the **STOP** button is pressed) in this mode is recorded as a single file.
- The 1394 connector does not output any signals.
- This function is not available if a **DIR ENTRY NG CARD** is inserted.
- A card inserted during recording is recognized after recording stops. Insert a card after the recording ends.

One-shot recording (ONE-SHOT REC)

This function records a single shot at each unit of time which has been set.

1 Check that the **OPERATION TYPE** item in the menu option **SCENE FILE** screen and **REC FORMAT** item in the menu option **RECORDING SETUP** screen are set as described below.

For details on menu operation, refer to [Using the menus] (page 116).

- **OPERATION TYPE** item:
VIDEO CAM
- Recording format:
They are available at 1080i/60i (50i), 1080i/30P (25P), 720P/60P (50P), 720P/30P (25P), or in SD at 60i (50i), 30P (25P).

2 Select **ONE SHOT** in the **REC FUNCTION** item in the menu option **RECORDING SETUP** screen.

3 Set the time in the **ONE SHOT TIME** item in the menu option **RECORDING SETUP** screen.

4 Press the **REC START/STOP** button.

- The camera will pause recording after making a recording that lasts the duration set in step 3.
- Press the **STOP** button to stop recording.
- To cancel this function, turn the camera off or select **NORMAL** in the **REC FUNCTION** item.
- The following indications appear to the left of the operation status display.
 - During recording: "I-REC" stays lit.
 - During a pause: "I-PAUSE" stays lit.
 - When stopped: "I-" in "I-PAUSE" blinks.

<Note>

- No other functions are available during operation.
- The pre-recording function is not available.
- Sound is not recorded.
- Data recorded (until the **STOP** button is pressed) in this mode is recorded as a single file.
- The 1394 connector does not output any signals.
- This function is not available if a **DIR ENTRY NG CARD** is inserted.
- During continuous one-shot recording, recording operation speed may be decreased.
- A card inserted during recording is recognized after recording stops. Insert a card after the recording ends.

Loop recording (LOOP REC)

- When two or more P2 cards are inserted in the P2 card slots, each card is recorded in succession.
- When there is no longer any space left on the cards, recording starts over from the first card by recording new clips over saved old clips.
For the clip recording time, see [Splitting clips recorded on P2 cards] (page 32).

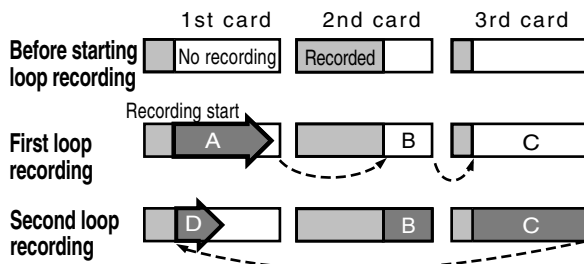

Recording will be made on the areas with no recording consecutively (A, B, then C). When all areas on all cards are recorded, new recording (D) will be made by overwriting the area A.

- 1 Check that the OPERATION TYPE item in the menu option SCENE FILE screen and REC FORMAT item in the menu option RECORDING SETUP screen are set as described below.

For details on menu operation, refer to [Using the menus] (page 116).

- OPERATION TYPE item: VIDEO CAM
- Recording format:
They are available at 1080i/60i (50i), 1080i/30P (25P), 720P/60P (50P), 720P/30P (25P), or in SD at 60i (50i), 30P (25P).

- 2 Select LOOP in the REC FUNCTION item in the menu option RECORDING SETUP screen.

- 3 Press the REC START/STOP button.

- Recording starts.
- Press the REC START/STOP button to stop recording.
- To cancel this function, turn the camera off or select NORMAL in the REC FUNCTION item.
- The following indications appear to the left of the operation status display.
 - During recording: "L-REC" stays lit.
 - During a pause: "L-PAUSE" stays lit.
 - When remaining memory is low: "P2 LACK L-" blinks.

<Note>

- Use a P2 card with at least one minute of remaining recording time.
- Switching to the mode check screen displays the minimum guaranteed recording time.
- This function is not available during IEEE1394 input.
- The pre-recording function is not available.
- This function is not available if a DIR ENTRY NG CARD is inserted.
- Canceling this function may take some time. The succeeding operations are not available until the P2 CARD ACCESS LED goes from blinking to steady lighting.
- A card inserted during recording is not used for recording.

Hot Swap Recording

With a P2 card in each card slot it is possible to make one continuous recording that spans all four cards. And by removing any card other than that being recorded, you can make continuous recording on 5 or more cards (hot swap recording).

Note that recognition of a P2 card may be delayed depending on when it is inserted in an empty card slot (for example, immediately after pre-recording or when a recording continues from one card to the next). P2 cards should be inserted when there is still 1 minute or more time left on the card that is being recorded.

- USER MAIN/USER1/USER2 in the setting menu SW MODE screen allows you to assign the SLOT SEL function to a USER button to enable selection of a recording slot with pushbutton ease.

<Note>

- Select the recording slot during standby as selecting is not available during recording.
- This function is not compatible with hot-swap playback.

Recording Check Function

- Pressing the RET button on the lens in the CAMERA mode will automatically play back the last two seconds or so of latest clip.
- Use this function to check that recording is performed normally. The camera returns to recording standby mode after playback. Playback may start from the beginning of a short clip.
- You can use the USER MAIN, USER1 and USER2 items to assign the RET button function to a USER button. Select these items from the setting menu SW MODE screen.

<Note>

Note that the playback during recording check will be recorded on a backup device connected to the IEEE1394 or SDI OUT connector.

Shot Marker (SHOT MARK) Recording Function

This function can be used to distinguish a clip from other clips by adding a thumbnail to each clip. This also makes possible to display or play back the marked clips only.

To add shot marks

- 1 In the setting menu SW MODE screen, assign SHOT MARK to a USER button (USER MAIN, USER1 or USER2).**

For details on menu operation, refer to [Using the menus] (page 116).

- 2 During recording, press the USER button to which the SHOT MARK function has been assigned.**

- “MARK ON” is displayed as a shot mark is inserted in the currently recorded clip.
- Pressing this key a second time displays “MARK OFF” and the shot mark is deleted.

<Note>

- Shot marks can be added also in the thumbnail display.
- The shot marker function is not available during loop recording. When this function is not available, pressing this button displays “INVALID”.
- Shot marks cannot be set or deleted during playback.
- Shot marks for video data created in a single hot-swap recording session consisting of multiple clips cannot be set or deleted unless all the P2 cards that contain the video data for the entire session are inserted.

Text Memo Recording Function

Text memo allows the user to insert a text memo with time code at any point during clip recording and playback.

This makes it possible to display only the thumbnails of the clips with text memos, or to display thumbnails and time codes of the text memo positions in order.

To add text memos

- 1 Use the setting menu SW MODE screen to assign the TEXT MEMO function to a USER button.**

For details on menu operation, refer to [Using the menus] (page 116).

- 2 During recording or playback, press the USER button to which the TEXT MEMO has been assigned.**

- “TEXT MEMO” is displayed and a text memo is inserted at the point the button is pressed.

<Note>

- You can insert up to 100 text memos per clip.
- The text memo function is not available during loop recording, interval recording and one-shot recording. When this function is not available, pressing this button displays “INVALID”.

Normal and Variable Speed Playback

■ Normal speed playback

Clips can be played back in the MCR mode. The PLAY button provides monochrome playback through the viewfinder and color playback on the LCD monitor. Connecting a color video monitor to the VIDEO OUT connector, SDI OUT connector and COMPONENT OUT connector at the same time will enable viewing of the playback video in color.

■ Fast-forward/fast-reverse playback

The FF and REW buttons provide 32× and 4× fast playbacks and fast reverse playbacks. In stop mode, this function will play back video at 32× speed and in playback mode, it will play back video at 4× speed.

■ Clip cue up

When playback is paused, the FF button locates the beginning of the next clip while maintaining the pause mode.

When playback is paused, the REW button locates the beginning of the current clip while maintaining the pause mode.

<Note>

- When a P2 card has just been removed or inserted or the MCR mode has just been engaged after turning on the power, it may take some time for the camera to read clip information. If this is the case, the thumbnail screen displays “UPDATING”.
- If a P2 card is inserted while another P2 card is being played back, the clips on the inserted P2 card will not be played back. A P2 card inserted during playback will be recognised after playback ends.
- If you perform variable speed playback on a clip split across more than one P2 card, sound may disappear for a moment. This is not a fault.
- To play back a clip in a format that differs from REC FORMAT, set MCR FORMAT on the setting menu RECORDING SETUP screen to the format of the clip to be played back.
- Playback of the audio channels CH5 to CH8 recorded on another device is not possible.

■ Variable speed search

Pressing the PLAY button during playback starts variable playback search at 1× speed.

In this mode, the PAGE/VAR button provides the following playback speeds:

- -24×, -12×, -4×, -2×, -1×, -1/5×, 1/5×, 1×, 2×, 4×, 12×, 24×

Pressing the PLAY button returns the camera to normal playback.

■ Frame-by-frame playback

In playback pause mode, the PAGE/VAR button provides frame-by-frame playback.

Frame-by-frame playback is performed at the following increments:

- 720P: 1/60 or 1/50 increments
- 720P/24PN, 30PN, 25PN: 1/24, 1/30, 1/25 increments
- 1080i, 480i, 576i: 1/30 or 1/25 increments

Video and recording formats

Multiple HD/SD formats

This unit supports recordings in 20 HD and SD video formats. 1080i/720p HD recording uses the DVCPRO HD codec, while SD recording is performed in DVCPRO50 / DVCPRO/DV multi-codec.

Video formats and codecs supported by this camera

Video format *1		Recording time *3	Recording codec
HD 59.94 Hz	1080/60i	64 minutes	DVCPRO HD
	1080/30P (over 60i)		
	1080/24P (over 60i)		
	1080/24PA (over 60i)		
	720/60P		
	720/30P (over 60P)		
	720/24P (over 60P)		
HD 50 Hz	720/30PN (Native)*2	128 minutes	DVCPRO HD
	720/24PN (Native)*2	160 minutes	
	1080/50i	64 minutes	
1080/25P (over 50i)			
720/50P			
720/25P (over 50P)			
SD 59.94 Hz	720/25PN (Native)*2	128 minutes	DVCPRO HD
	480/60i	128 minutes (DVCPRO 50) 256 minutes (DVCPRO/DV)	
	480/30P (over 60i)		
480/24P (over 60i)			
SD 50 Hz	480/24PA (over 60i)	256 minutes (DVCPRO/DV)	DVCPRO 50 / DVCPRO/DV
	576/50i		
	576/25P (over 50i)		

*1 24P and 30P indicate recording at 23.98P and 29.97P, respectively, while 60P and 60i indicate recording at 59.94P and 59.94i, respectively.

*2 Native mode is a mode that records only effective frames.

*3 The listed recording times are for four 16 GB P2 cards. Using only one 16 GB card will reduce the recording time to 1/4. In addition to the video format and codec, function setup and the number of cuts will affect the recording time.

Selecting recording signals in CAMERA MODE

CAMERA MODE allows you to record video shot with the camera.

Use the setting menus listed below to select recording signals.

Setting menu	Setting
SYSTEM FREQ (OTHER FUNCTIONS screen)	Set system frequency (59.94 Hz, 50 Hz). When this setting is changed, wait for the "TURN POWER OFF" message to appear to turn the power off and then turn it back on again.
REC FORMAT (RECORDING SETUP screen)	<ul style="list-style-type: none"> Select formats and frame rates for recording and capture. Select combinations of recording formats (1080i, 720P, 480i/576i) and frame rates (60P/50P, 60i/50i, 30P/25P, 24P, 24PA). 720P/30PN, 24PN and 25PN are native recording formats.
FRAME RATE (SCENE FILE screen)	Setting FILM CAM in the setting menu OPERATION TYPE (SCENE FILE screen) makes it possible to select the 720P mode capture frame rate. For details, see [Variable Frame Rate (VFR) Recording] (page 37).
480i (576i) REC MODE (RECORDING SETUP screen)	In SD mode (480i, 576i) you can select DVCPRO50 or DVCPRO/DV recording mode.
ASPECT CONV (CAMERA SETUP screen)	In SD mode (480i, 576i), select the aspect ratio for video.

Selecting MCR mode recording and playback signals

MCR mode allows you to record signals from the 1394 connector and play back P2 card clips.

Use the setting menus listed below to select recording or playback signals.

Setting menu	Setting
SYSTEM FREQ (OTHER FUNCTIONS screen)	Set system frequency. (59.94 Hz, 50 Hz) When this setting is changed, wait for the "TURN POWER OFF" message to appear to turn the power off and then turn it back on again.
MCR FORMAT (RECORDING SETUP screen)	<ul style="list-style-type: none"> ● Select the format for recording signals input to the 1394 connector or format for playing back P2 card clips. ● Recording and playback of 1080i, 720P and 480i/576i are possible. ● 720P/30PN, 720P/24PN and 720P/25PN enable playback of clips recorded at respective native frame rate. ● In a change from CAMERA MODE to MCR mode, the REC FORMAT recording format is retained.
480i (576i) MCR MODE (RECORDING SETUP screen)	<ul style="list-style-type: none"> ● In SD mode (480i, 576i), you can select DVCPRO50 or DVCPRO/DV for recording 1394 connector signals or as playback mode to play back P2 card clips. ● In a change from CAMERA mode to MCR mode, the 480i (576i) REC MODE is retained.

Selecting video output

CAMERA MODE and MCR mode allow you to select video output format.

Use the setting menus listed below to select video output.

Setting menu	Setting
CMPNT/SDI SEL (OUTPUT SEL screen)	Select the signal format (AUTO, 1080i, 480i/576i) to be output from the COMPONENT OUT connector and SDI OUT connector.
SETUP (CAMERA SETUP screen) • 59.94 Hz system	Select the setup level for the 480i video signal. <ul style="list-style-type: none"> ● 0%: Setup 0% also for output and recording ● 7.5%A: 7.5% setup level for output only (0% for recording) The SETUP menu setting is enabled also during playback.
DOWNCON MODE (DISPLAY SETUP screen)	Select the screen type to be output (COMPONENT OUT, SDI OUT when VIDEO OUT and CMPNT/SDI SEL is down converted to 480i or 576i) and down-converted in HD mode (1080i, 720P).

<Note>

The audio and video may be disturbed when the REC FORMAT and MCR FORMAT is changed in the setting menu SYSTEM FREQ, but this is not a camera malfunction.

List of recording, playback and output formats

CAMERA mode (recording)

■SYSTEM FREQ (setting menu): 59.94 Hz

Format setting	Recording status			Output setting	Output status				
REC FORMAT	Capture and recording frame rate	Recording format	Audio recording channels	CMPNT/SDI SEL	SDI OUT	SDI OUT AUDIO	COMPONENT OUT	VIDEO OUT	1394 output
1080i/60i	60i	DVCPRO HD 1080i/59.94i	4ch	AUTO	1080i/59.94i	4ch	1080i/59.94i	525i/59.94i	DVCPRO HD 1080i/59.94i
1080i/30P	30P over 60i			1080i	1080i/59.94i		1080i/59.94i		
1080i/24P	24P over 60i			480i	525i/59.94i		525i/59.94i		
1080i/24PA	24PA over 60i								
720P/60P	60P*1	DVCPRO HD 720P/59.94P	4ch	AUTO	720P/59.94P*1	4ch	720P/59.94P*1	525i/59.94i	DVCPRO HD 720P/59.94P*1
720P/30P	30P over 60i*1			1080i	1080i/59.94i		1080i/59.94i		
720P/24P	24P over 60i*1			480i	525i/59.94i		525i/59.94i		
720P/30PN	30P native recording at 30P capture*2	DVCPRO HD 720P/29.97P	4ch*5	AUTO	720P/59.94P*1	4ch*5	720P/59.94P*1	525i/59.94i	No output
720P/24PN	24P native recording at 24P capture*3			1080i	1080i/59.94i		1080i/59.94i		
				480i	525i/59.94i		525i/59.94i		
480i/60i	60i	DVCPRO50, DVCPRO/DV*4 480i/59.94i	4CH or 2CH*6	Disabled	525i/59.94i	4CH or 2CH*6	525i/59.94i	525i/59.94i	DVCPRO50, DVCPRO/DV*4 525i/59.94i
480i/30P	30P over 60i								
480i/24P	24P over 60i								
480i/24PA	24PA over 60i								

*1 In FILM CAM mode, this means 12P to 60P capture over 60P depending on FRAME RATE menu setting.

*2 In FILM CAM mode, this means VFR recording at 12P to 60P capture depending on FRAME RATE menu setting. (playback at 30P over 60P)

*3 In FILM CAM mode, this means VFR recording at 12P to 60P capture depending on FRAME RATE menu setting. (Playback at 24P over 60P)

*4 Select DVCPRO50 or DVCPRO/DV according to 480i (576i) REC MODE.

*5 Audio is not recorded or output unless the FRAME RATE is set to DEFAULT or 30FRAME in 720P/30P. Audio is not recorded or output unless the FRAME RATE is set to DEFAULT or 24FRAME in 720P/24P.

*6 In the 25M REC CH SEL menu, select 4CH for DVCPRO50 mode and 2H/4CH in DVCPRO/DV mode.

■ SYSTEM FREQ (setting menu): 50 Hz

Format setting	Recording status			Output setting	Output status				
REC FORMAT	Capture and recording frame rate	Recording format	Audio recording channels	CMPNT/SDI SEL	SDI OUT	SDI OUT AUDIO	COMPONENT OUT	VIDEO OUT	1394 output
1080i/50i	50i	DVCPRO HD 1080i/50i	4ch	AUTO	1080i/50i	4ch	1080i/50i	625i/50i	DVCPRO HD 1080i/50i
1080i/25P	25P over 50i			1080i	1080i/50i		1080i/50i		
				576i	625i/50i		625i/50i		
720P/50P	50P* ⁷	DVCPRO HD 720P/50P	4ch	AUTO	720P/50P* ⁷	4ch	720P/50P* ⁷	625i/50i	DVCPRO HD 720P/50P* ⁷
720P/25P	25P over 50P* ⁷			1080i	1080i/50i		1080i/50i		
				576i	625i/50i		625i/50i		
720P/25PN	25P native recording at 25P capture* ⁸	DVCPRO HD 720P/25P	4ch* ⁹	AUTO	720P/50P* ⁷	4ch* ⁹	720P/50P* ⁷	625i/50i	No output
				1080i	1080i/50i		1080i/50i		
				576i	625i/50i		625i/50i		
576i/50i	60i	DVCPRO50, DVCPRO/DV* ⁴ 625i/50i	4CH or 2CH* ⁶	Disabled	625i/50i	4CH or 2CH* ⁶	625i/50i	625i/50i	DVCPRO50, DVCPRO/DV* ⁴ 625i/50i
576i/25P	25P over 50i								

*⁴ Select DVCPRO50 or DVCPRO/DV according to 480i (576i) REC MODE.

*⁶ In the 25M REC CH SEL menu, select 4CH for DVCPRO50 mode and 2H/4CH in DVCPRO/DV mode.

*⁷ In FILM CAM mode, this means 12P to 50P capture depending on FRAME RATE menu setting.

*⁸ In FILM CAM mode, this means VFR recording at 12P to 50P capture depending on FRAME RATE menu setting. (Playback at 25P over 50P)

*⁹ Audio is not recorded or output unless the FRAME RATE is set to DEFAULT or 25FRAME in 720P/25PN.

MCR mode (playback and recording of 1394 input)

■SYSTEM FREQ (setting menu): 59.94 Hz

Format setting	Recording status		Output setting	Output status				
MCR FORMAT	1394 recording and playback format	Recording and playback audio channel	CMPNT/SDI SEL	SDI OUT	SDI OUT AUDIO	COMPONENT OUT	VIDEO OUT	Playback of 1394 output
1080i/60i	DVCPRO HD 1080i/59.94i	4ch	AUTO	1080i/ 59.94i	4ch	1080i/59.94i	525i/ 59.94i	DVCPRO HD 1080i/59.94i
			1080i	1080i/ 59.94i		1080i/59.94i		
			480i	525i/ 59.94i		525i/59.94i		
720P/60P	DVCPRO HD 720P/59.94P	4ch	AUTO	720P/ 59.94P	4ch	720P/59.94P	525i/ 59.94i	DVCPRO HD 720P/59.94P
			1080i	1080i/ 59.94i		1080i/59.94i		
			480i	525i/ 59.94i		525i/59.94i		
720P/30PN	DVCPRO HD 720P/59.94P* ₁ * ₂	4ch* ₅	AUTO	720P/ 59.94P* ₁ * ₂	4ch* ₅	720P/59.94P* ₁ * ₂	525i/ 59.94i* ₁	DVCPRO HD 720P/59.94P* ₂
			1080i	1080i/ 59.94i* ₁		1080i/59.94i* ₁		
			480i	525i/ 59.94i* ₁		525i/59.94i* ₁		
720P/24PN	DVCPRO HD 720P/59.94P* ₁ * ₃	4ch* ₅	AUTO	720P/ 59.94P* ₁ * ₃	4ch* ₅	720P/59.94P* ₁ * ₃	525i/ 59.94i* ₁	DVCPRO HD 720P/59.94P* ₂
			1080i	1080i/ 59.94i* ₁		1080i/59.94i* ₁		
			480i	525i/ 59.94i* ₁		525i/59.94i* ₁		
480i/60i	DVCPRO50, DVCPRO/DV* ₆ 525i/59.94i	4CH, or 2CH * ₇	Disabled	525i/ 59.94i	4CH, or 2CH * ₇	525i/59.94i	525i/ 59.94i	DVCPRO50, DVCPRO/DV* ₆ 525i/59.94i

■SYSTEM FREQ (setting menu): 50 Hz

Format setting	Recording status		Output setting	Output status				
MCR FORMAT	1394 recording and playback format	Recording and playback audio channel	CMPNT/SDI SEL	SDI OUT	SDI OUT AUDIO	COMPONENT OUT	VIDEO OUT	Playback of 1394 output
1080i/50i	DVCPRO HD 1080i/50i	4ch	AUTO	1080i/50i	4ch	1080i/50i	625i/ 50i	DVCPRO HD 1080i/50i
			1080i	1080i/50i		1080i/50i		
			576i	625i/50i		625i/50i		
720P/50P	DVCPRO HD 720P/50P	4ch	AUTO	720P/50P	4ch	720P/50P	625i/ 50i	DVCPRO HD 720P/50P
			1080i	1080i/50i		1080i/50i		
			576i	625i/50i		625i/50i		
720P/25PN	DVCPRO HD 720P/25P* ₁ * ₄	4ch* ₅	AUTO	720P/50P* ₁ * ₄	4ch* ₅	720P/50P* ₁ * ₄	625i/ 50i* ₁	DVCPRO HD 720P/50P* ₄
			1080i	1080i/50i* ₁		1080i/50i* ₁		
			576i	625i/50i* ₁		625i/50i* ₁		
576i/50i	DVCPRO50, DVCPRO/DV* ₆ 625i/50i	4CH, or 2CH* ₇	Disabled	625i/50i	4CH, or 2CH* ₇	625i/50i	625i/ 50i	DVCPRO50, DVCPRO/DV* ₆ 625i/50i

*₁ 1394 input cannot be recorded and the output produces a black screen.

*₂ Playback is converted to over 60P using a 2:2 pulldown.

*₃ Playback is converted to over 60P using a 2:3 pulldown.

*₄ Playback is converted to over 50P using a 2:2 pulldown.

*₅ Clips recorded without sound are played back without sound.

*₆ Format will be any of DVCPRO50 or DVCPRO/DV, depending on 480i (576i) MCR mode.

*₇ 4CH for DVCPRO50, and 2CH or 4CH for DVCPRO/DV.

Adjusting the White balance and Black Balance

To record high-quality video with the AG-HPX500P/E, the black and white balances must be adjusted according to conditions.

For higher quality, it is recommended that the adjustments should be made in this order AWB (white balance adjustment) → ABB (black balance adjustment) → AWB (white balance adjustment).

Adjusting the White Balance

Whenever light conditions change, the white balance must be readjusted.

To adjust the white balance, follow the steps below.

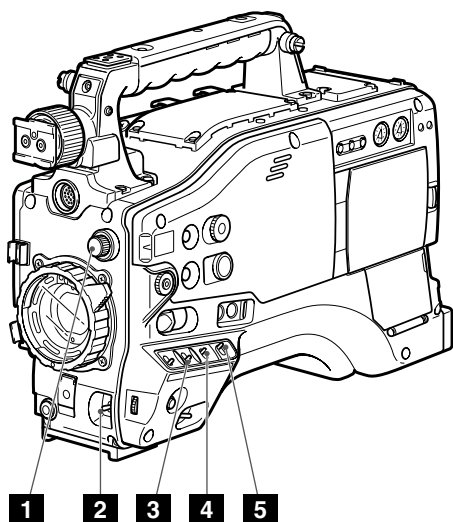

- 1 ND FILTER control**
This control adjusts the amount of light entering the CCD.
- 2 AUTO W/B BAL switch**
Use for automatic control of white balance.
- 3 GAIN selector switch**
Normally set to 0 dB. If this is too dark, adjust gain as necessary.
- 4 OUTPUT selector switch**
Set to CAM.
- 5 WHITE BAL switch**
Set to A or B.

1 Set the GAIN, OUTPUT and WHITE BAL switches.

2 Adjust the ND FILTER control according to the light conditions.

For examples of ND FILTER adjustments, see [Shooting and Recording/Playback Functions Section] (page 19).

3 Place a white pattern at a point where the light conditions match those for the light source of the subject. Then zoom-in on the white pattern so that white colour appears in the screen.

- A white object (cloth or wall) may be used instead of a white pattern. The illustration below shows the required size for the white space.

<Note>

- Do not include a high-intensity spot in the screen.
- The white object must appear at the center of the screen.

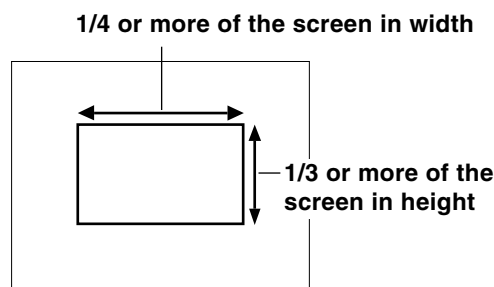

4 Adjust the lens iris.

- Display the center marker and adjust the iris to obtain a 70% indication.

5 Turn the AUTO W/B BAL switch toward [AWB] and release it.

- The switch returns to the central position with the white balance automatically adjusted.

6 During an adjustment, the viewfinder displays the following message:

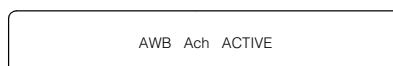

7 The adjustment will take effect in a few seconds, and the following message will appear:

- The adjusted value is automatically stored in the selected memory (A or B).



- “C TEMP+7” to “C TEMP-7” will appear when COLOR TEMP of the scene file is set to the value other than 0.

8 If the subject’s colour temperature is lower than 2300K or higher than 9900K the following message appears:

- If the arrow points down (↓) the actual colour temperature is lower than the temperature indicated. If the arrow points up (↑) the actual temperature is higher than the temperature indicated.



When you have no time to adjust the white balance

- Position the WHITE BAL switch at [PRST].
- Turning the AUTO W/B BAL switch to AWB toggles the color temperature between 3200K and 5600K.

When the white balance has not been automatically adjusted

When the white balance has not been successfully adjusted, the viewfinder displays an error message.

Error message	Description
AWB NG	The color temperature is too high or too low.
LOW LIGHT	There is insufficient light.
LEVEL OVER	There is too much light.

Viewfinder displays related to white balance

See [Viewfinder Screen Status Displays] (page 67).

Adjusting the Black Balance

The black balance must be adjusted when:

- You use your AG-HPX500P/E the first time.
- Your AG-HPX500P/E has not been used for some time.
- The ambient temperature has changed substantially.
- The gain switchover value has been changed.

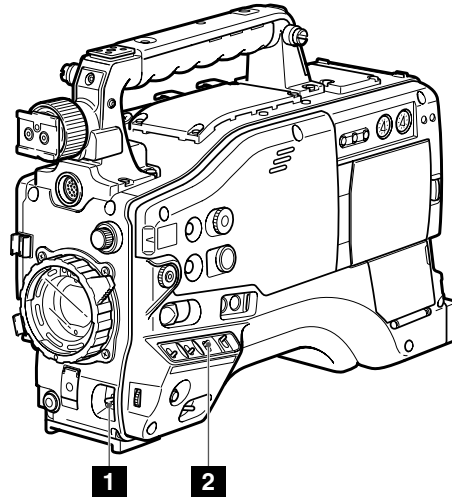

- 1 AUTO W/B BAL switch**
Use for automatic control of white balance.
- 2 OUTPUT selector switch**
Set to CAM.

1 Tilt the AUTO W/B BAL switch so that it is positioned at [ABB], then release it.

- The switch returns to the central position with the black balance automatically adjusted.

2 During adjustment, the viewfinder displays the following message:

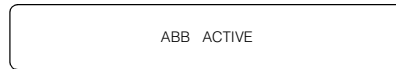

<Note>
During adjustment, the lens iris automatically becomes CLOSE.

3 The adjustment will take effect in a few seconds and the following message will appear:

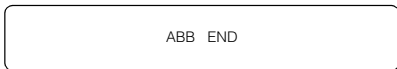

- The adjusted value is automatically stored in the memory.

<Note>

- Ensure that the lens connector is connected and the lens iris is CLOSE.
- During a black balance adjustment, light is automatically cut off.

.....
Retaining black balances

Each value in memory is retained even if the video camera-recorder is turned off.

Setting the Electronic Shutter

Setting the Shutter Mode and Speed

- 1 Press the SHUTTER switch positioned at OFF towards ON.

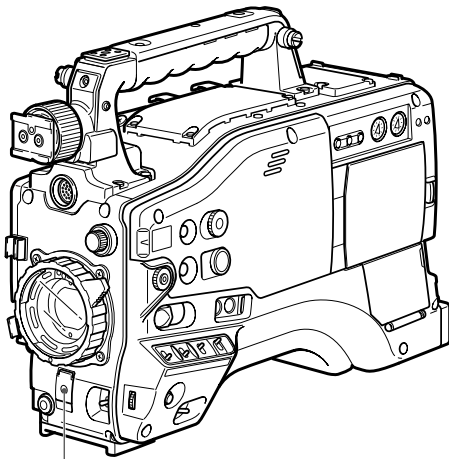

SHUTTER switch

- 2 Press the SHUTTER switch towards [SEL]. Repeat this switchover until the desired mode or speed appears in the viewfinder screen.

- If all modes and speeds are available, the display changes in the following order:

60 Hz mode

For 60i and 60P recording

S/S → (1/15) → (1/30) → 1/100 → 1/120 → 1/250
→ 1/500 → 1/1000 → 1/2000

For 30P recording

S/S → (1/15) → 1/50 → 1/60 → 1/120 → 1/250
→ 1/500 → 1/1000

For 24P recording (excluding 720P/24P and 720P/24PN)

S/S → 1/50 → 1/60 → 1/120 → 1/250 → 1/500
→ 1/1000

For 24P recording (at 720P/24P or 720P/24PN)

S/S → (1/12) → 1/50 → 1/60 → 1/120 → 1/250
→ 1/500 → 1/1000

50 Hz mode

For 50i and 50P recording

S/S → (1/12) → (1/25) → 1/60 → 1/120 → 1/250
→ 1/500 → 1/1000 → 1/2000

For 25P recording

S/S → (1/12) → 1/50 → 1/60 → 1/120
→ 1/250 → 1/500 → 1/1000

<Note>

- In any electronic shutter mode, a slower shutter speed will reduce camera sensitivity.
- In auto iris mode, a faster shutter speed will increase the aperture and lower the depth of field.
- When OPERATION TYPE on the setting menu SCENE FILE screen is set to FILM CAM, the shutter speed indication in () does not change.

Viewfinder displays relating to the shutter

See [Viewfinder Screen Status Displays] (page 67).

Placing the Camera-recorder in SYNCHRO SCAN Mode

To place the camera-recorder in SYNCHRO SCAN mode, follow the steps below.

- 1 Press the **SHUTTER** switch positioned at [ON] towards [SEL], to place the camera-recorder in SYNCHRO SCAN (S/S) mode.

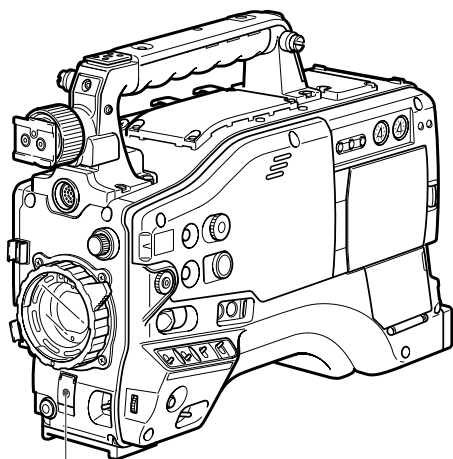

SHUTTER switch

- 2 In SYNCHRO SCAN mode, the speed can be switched seamlessly between 1/60.0 and 1/249.8 seconds, using the JOG dial button. (Speed switchover is enabled in 60i mode.)

Range of variation in each mode

■59.94 Hz mode

- 60P/60i mode: 1/60.0 to 1/249.8
- 30P/30PN mode: 1/30.0 to 1/249.8
- 24P/24PA/24PN mode: 1/24.0 to 1/249.8
- FILM CAM mode*: 10.0d to 360.0d

■50 Hz mode

- 50P/50i mode: 1/50.0 to 1/248.9
- 25P/25PN mode: 1/25.0 to 1/248.9
- FILM CAM mode*: 10.0d to 360.0d

* Setting FILM CAM in the OPERATION TYPE item in the setting menu SCENE FILE screen enables setting and display in opening.

Assigning functions to USER buttons

The USER MAIN, USER1, and USER2 buttons can be assigned user-selected functions. Use the menu options USER MAIN, USER1, and USER2 to assign functions to respective button. Select these items from the setting menu SW MODE screen.

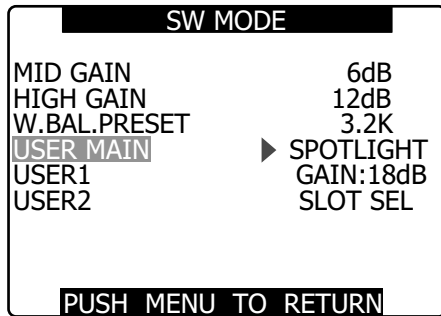

Selectable Functions

- **REC CHECK:** Assigns recording check.
- **SPOTLIGHT:** Assigns auto iris control on/off for spotlight.
- **BACKLIGHT:** Assigns auto iris control for backlight compensation.
- **BLACKFADE:** Assigns blackfade.
- **WHITEFADE:** Assigns whitefade.
- **GAIN 18dB:** Assigns a gain increase of 18 dB.
- **TEXT MEMO:** Assigns text memo recording.
- **SLOT SEL:** Assigns P2 card slot selection.
- **SHOT MARK:** Assigns shot marker function.
- **LVL METER:** Assigns channel level indicator function.
- **MARKER:** Assigns the center marker indicator function.
- **LCD REV:** Assigns the function that flips the LCD image vertically and horizontally.

<Note>

The default settings are listed below.

USER MAIN: SHOT MARK

USER1: BACK LIGHT

USER2: LVL METER

Selecting Audio Input Signals and Adjusting Recording Levels

This AG-HPX500P/E supports independent four-channel audio recording in any format (HD or SD). When the AUDIO SELECT CH1/CH2 switch is positioned at [AUTO], the recording levels for Audio Channels 1 and 2 are automatically adjusted. To manually adjust the recording levels, position the switch at [MAN].

Note that the recording levels for Audio Channels 3 and 4 are selected through a menu option.

Selecting Audio Input Signals

The input signals to be recorded on Audio Channels 1, 2, 3, and 4 are selected with the AUDIO IN switch. For more information, see [Audio (input) Function Section] (page 16).

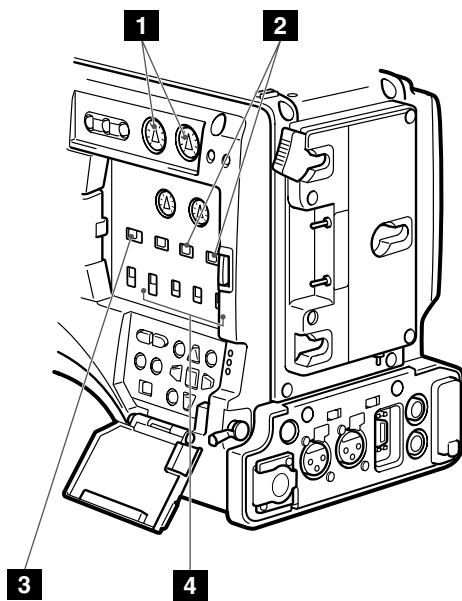

- 1 AUDIO LEVEL CH1/CH2 controls
- 2 AUDIO SELECT CH1/CH2 switch
- 3 MONITOR SELECT CH1/3 / ST / CH2/4 selector switch
- 4 AUDIO IN switch

Your AG-HPX500P/E is factory-set to perform no recording on Audio Channels 3 and 4 in the DVCPRO and DV formats. To enable four-channel recording, the menu option 25M REC CH SEL on the AUDIO SETUP screen must be set to 4CH.

For details on switch settings and the input system, see [AUDIO IN switch] (page 16).

<Note>

- The audio signals recorded on the four channels are output as is (SDI).
- With a front microphone (such as AG-MC200G) connected, setting CH1 of the AUDIO IN switch to FRONT2, setting CH2-CH4 to FRONT and setting the MONITOR SELECT CH1/2 / CH3/4 selector switch to CH3 or CH4 will result in no sound output to CH3.

Use the AUDIO SETUP screen in the setting menu to make detailed audio settings.

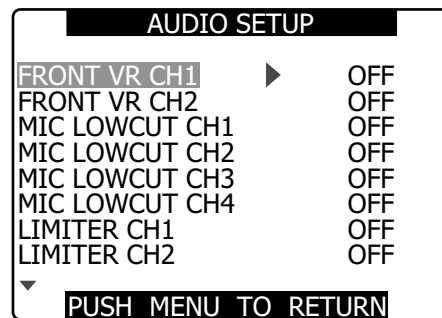

Adjusting Recording Levels

To adjust the recording levels for Audio Channels 1 and 2, follow the steps below.

- 1 Position the MONITOR SELECT CH1/2 / CH3/4-selector switch at CH1/2 so that the audio level meter on the display window will provide CH1 and CH2 indications. Ensure that the channel indications displayed in the window are 1 and 2.
- 2 Position the AUDIO SELECT CH1/CH2 switch at [MAN].

3 While checking the audio channel level meter in the display window or the audio level meter in the viewfinder, adjust the AUDIO LEVEL CH1/CH2 control.

- Note that if the level exceeds the top bar (0 dB), the word OVER illuminates to show that the input level is excessive. The adjustment made in such a way that the maximum level will not reach the 0 dB bar.



When operating the AG-HPX500P/E without a sound recordist, it is recommended that the FRONT AUDIO LEVEL control should be used to adjust the audio level.

In advance, check the level meter in the viewfinder screen and use the FRONT AUDIO LEVEL control to adjust the appropriate audio channel so that no excessive audio signals will be admitted.

Selecting Function for the FRONT AUDIO LEVEL Control

Use the menu options FRONT VR CH1 and FRONT VR CH2 to determine whether or not to enable control of selected input signals using the FRONT AUDIO LEVEL control. Selecting the ON setting enables FRONT AUDIO LEVEL control operation. Select these items from the setting menu AUDIO SETUP screen.

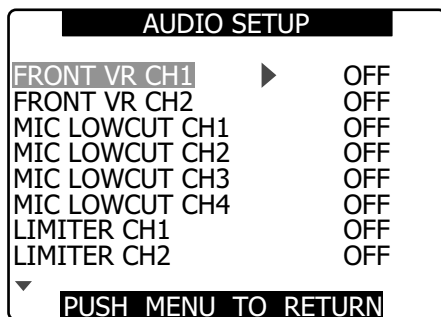

CH3 and CH4 Recording Levels

Set the menu options AUTO LEVEL CH3 and AUTO LEVEL CH4 in the AUDIO SETUP screen of the setting menu to OFF to adjust the recording level with the AUDIO LEVEL CH3 and CH4 controls.

Setting Time Data

This camera records time data such as the time code, user bits, date and time (real time) data in the subcode area, VIDEO AUX area and in clip meta data files.

Time data overview

Time code

Use the TCG switch to select Rec Run or Free Run mode.

- Free Run: The time code advances constantly whether the camera is on or not just like time itself. Recording using a slave-locked time code input to the TC IN or 1394 connectors is also possible.
- Rec Run: The time code advances only during recording. This will enable continuation of time codes in previously recorded clips and when the power is turned off or new P2 cards are inserted to continue recording.

<Note>

The following events will disrupt time code continuity.

- When clips are deleted
- When a 24P or 24PA frame rate is selected
- When 24PN, 30PN or 25PN is selected
- When a recording is interrupted by a REC WARNING or other abnormality

User bits

- There are two types of user bits. The user bits (UB) that are recorded in the subcode area and the user bits (VITC UB) that are recorded in the VIDEO AUX area.
- The subcode user bits enable the recording of user settings, time, date, time code and similar values, the frame rate data for camera capture, external input values (via TC IN or 1394 connector input).
- VITC user bits record the frame rate data of camera capture.
- The clip meta data user bit records the user bit values in the subcode area at start of recording.

■Date (real time)

- The built-in clock calculates the year, month, day and time from the internal clock to display on video in the LCD, viewfinder and VIDEO OUT and other video output.
- The internal clock is not only used to calculate the free run time code when the power is off and to set the user bit year, date and time, but also to set file creation dates when clips are recorded that determine the order of thumbnails and playback order.
- It is also used to generate clip meta data and UMID in the VIDEO AUX area.
For details, see [Setting Date and Time of Internal Clock] (page 28).

Recording time codes and user bits

These values are recorded as listed below depending on system frequency and recording format.

MODE. SYSTEM FREQ	REC MODE/ MCR MODE	FRAME RATE (FILM CAM)	Subcode area time code	VIDEO AUX area time code (VITC)	Recorded time code frames	Output time code frames	Displayed time code frames	Subcode area user bits	VIDEO AUX area user bits (VITC UB)
59.94 Hz CAMERA mode	1080i/60i 1080i/30P	Not related	Depends on time code mode*1	Depends on time code mode*1	30	30	30/24 switchable*7	Depends on user bits mode*4	Locked to frame rate data
	1080i/24P 1080i/24PA	Not related	Locked to non-drop frame rate*2	Locked to non-drop frame rate*2	30	30	30/24 switchable*7	Depends on user bits mode*4	Locked to frame rate data
	720P/60P 720P/30P 720P/24P	12P to 60P (except at 24P)	Depends on time code mode*1	Depends on time code mode*1	30	30	30/24 switchable*7	Depends on user bits mode*4	Locked to frame rate data
		24P	Locked to non-drop frame rate*2	Locked to non-drop frame rate*2	30	30	30/24 switchable*7	Depends on user bits mode*4	Locked to frame rate data
	720P/30PN	12P to 60P	Depends on time code mode*1+6	Depends on time code mode*1+6	30	30	Locked at 30	Depends on user bits mode*4	Locked to frame rate data
	720P/24PN	12P to 60P	Locked to non-drop frame rate*2+6	Locked to non-drop frame rate*2+6	24	30	Locked at 24	Depends on user bits mode*4	Locked to frame rate data
	480i/60i 480i/30P	Not related	Depends on time code mode*1	Depends on time code mode*1	30	30	30/24 switchable*7	Depends on user bits mode*4	Locked to frame rate data
480i/24P 480i/24PA	Not related	Locked to non-drop frame rate*2	Locked to non-drop frame rate*2	30	30	30/24 switchable*7	Depends on user bits mode*4	Locked to frame rate data	
59.94 Hz MCR mode (recording of 1394 input)	1080i/60i 720P/60P 480i/60i	Not related	Depends on time code mode*3	Records VIDEO AUX area time code input via 1394 regardless of setting	30	30	30/24 switchable*7	Depends on user bits mode*5	Records VIDEO AUX area user bits input via 1394 regardless of setting
	720P/30PN	Not related	Not recorded (Playback 30: frame)	Not recorded (Playback 30: frame)	—	— (Playback: 30)	— (Playback: locked at 30)	Not recorded	Not recorded (playback: frame rate data is converted and generated in synch with video pull-down)
	720P/24PN	Not related	Not recorded (playback 30: frame)	Not recorded (playback 30: frame)	—	— (Playback: 30)	— (Playback*8: 30/24 switchable)	Not recorded	Not recorded (playback: frame rate data is converted and generated in synch with video pull-down)
50 Hz CAMERA mode	1080i/50i 1080i/25P	Not related	*1	*1	25	25	Locked at 25	Depends on user bits mode*4	Locked to frame rate data
	720P/50P 720P/25P	12P to 50P							
	720P/25PN	12P to 50P	*1*6	*1*6					
	576i/50i 576i/25P	Not related	*1	*1					
50 Hz MCR mode (recording of 1394 input)	1080i/50i 720P/50P 576i/50i	Not related	*3	Records VIDEO AUX area time code input via 1394 regardless of setting	25	25	Locked at 25	Depends on user bits mode*5	Records VIDEO AUX area user bits input via 1394 regardless of setting
	720P25PN	Not related	Not recorded	Not recorded	—	— (Playback: 25)	— (Playback: 25)	Not recorded	Not recorded (playback: frame rate data is converted and generated in synch with video pull-down)

*1 In Free Run mode, slaved to time code input to the TC IN connector.

*2 In Free Run mode, slaved to non-drop frame time code input to the TC IN connector.

*3 Setting F-RUN TC SAVE to 1394 in Free Run mode slaves it to the input from the 1394 connector, not to the TC IN connector input.

*4 Setting TC IN UB REGEN to ON in the setting menu slaves it to user bits input to the TC IN connector.

*5 Setting 1394 UB REGEN to ON in the setting menu slaves it to user bits input to the 1394 connector.

*6 Should the set capture frame rate differ from the recording frame rate, it is locked to Rec Run (not slaved)

*7 Only in FILM CAM mode. In VIDEO CAM mode, it is locked at 30 frames.

*8 Only in FILM CAM mode. In VIDEO CAM mode, it is locked at 24 frames.

Setting user bits

Use the setting menu UB MODE on the RECORDING SETUP screen to select the user bits to record in the subcode area.

• USER

Records internal user values.

To set user values, set the TCG switch to SET to open the setting menu TC PRESET screen.

Set values are retained after the power is turned off.

See also [Entering the User Bits] (page 60).

• TIME

Records the time calculated by the internal clock.

• DATE

Records the year, month and day time digits from the internal clock.

• TCG

Records the time code value.

• FRM. RATE

Records the frame rate information of camera capture.

A natively recorded clip is output at the same frame rate as the user bit in the VIDEO AUX area regardless of recorded values. Use this setting when a PC or other editing device is to use the user bit frame rate.

For details, see [Frame Rate Information Recorded in User Bits] (page 61).

- To slave lock to user bit input to the TC IN connector, set the setting menu TC IN UB REGEN on the RECORDING SETUP screen to ON.

- To slave lock to user bit input to the 1394 connector during recording of input from the 1394 connector in MCR MODE, set the setting menu 1394 UB REGEN to ON.

- In slave mode, the UB indicator is highlighted. In this status, the UB MODE setting is disabled.

- A slave relationship, once started, continues even after input from the TC IN or 1394 connector ends. However, the following events release a user bit slave status.

- When the setting menu TC IN UB REGEN or 1394 UB REGEN is set to OFF.

- UB PRESET is performed
- CAMERA/MCR mode switching
- The power is turned off

The internal user value retains the slave values even after slave release.

Entering the User Bits

The user bits allow information, including memos that use up to eight-digit hexadecimal numbers (date and time), to be recorded in the Subcode area.

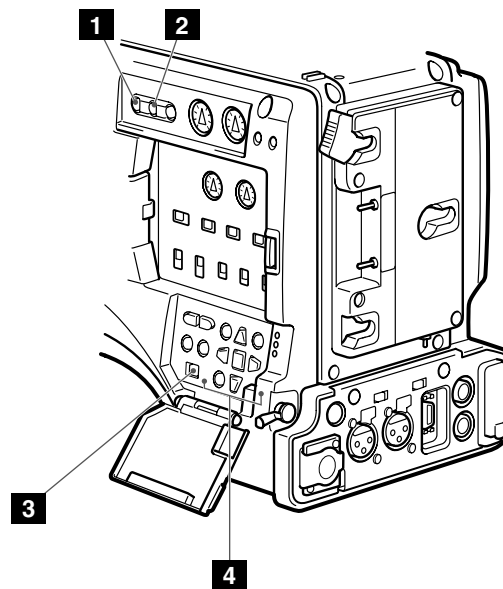

- 1** HOLD button
- 2** COUNTER button
- 3** TCG switch
- 4** CURSOR and SET buttons

- 1** Set the COUNTER button to UB.

- 2** Position the TCG switch at [SET].
 - When the left digit starts blinking you can change the value.

3 Use CURSOR buttons to set the user bits.

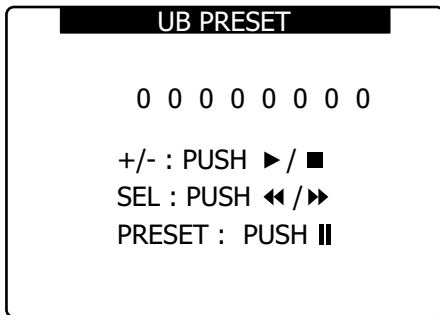

- ▶ button: Shifts the target (highlighted) digit to the right.
- ◀ button: Shifts the target (highlighted) digit to the left.
- ▲ button: Increases the highlighted number by one.
- ▼ button: Decreases the highlighted number by one.
- || (SET) button: Confirms the set user bits.
 - Pressing the RESET button while setting the user bits will reset any user bit setting to 0.

4 Press the SET button to confirm the user bit value, and position the TCG switch at F-RUN or R-RUN.

<Note>
Changing the TCG switch setting without pressing the SET button disables the set value.

5 Open the setting menu RECORDING SETUP screen and set the menu option UB MODE to USER.

Retaining the user bits

The data set for the user bits are automatically saved and retained even if the video camera-recorder is turned off.

Frame rate information recorded in user bits

Video is captured at the frame rate set in the setting menu REC FORMAT (setting menu FRAME RATE in FILM CAM 720P) and the recorded video information is recorded in the user bits to allow use in an editing device (PC editing software). In CAMERA mode recording, this information is always recorded in the VIDEO AUX area user bits. Setting the setting menu UB MODE to FRM. RATE, records the information also to the user bits in the subcode area. In playback of clips recorded at 720P native, the same frame rate information as that obtained in playing back the user bits in the VIDEO AUX area is also output to the user bits in the subcode area.

Frame rate information

Frame rate, video pull-down and time code user bits are related as described below.

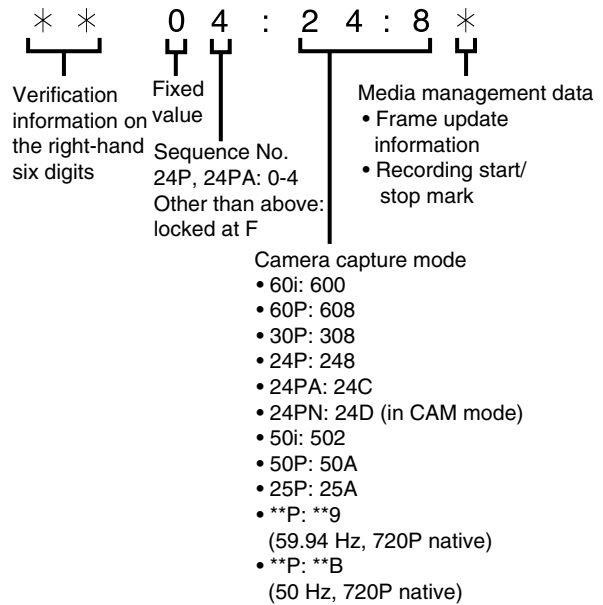

When 1080i, 480i or 576i

Frame rate: 24P over 60i (2:3)

First field of updated frame rate

Time code digit

00	01	02	03	04	05	06	...	23	24	25	26	27	28	29
----	----	----	----	----	----	----	-----	----	----	----	----	----	----	----

Video

A0	Ae	B0	Be	Bc	C0	Co	De	Do	De	A0	Ae	B0	Be	...	C0	Co	De	Do	De	A0	Ae	B0	Be	Bc	C0	Co	De	Do	De
----	----	----	----	----	----	----	----	----	----	----	----	----	----	-----	----	----	----	----	----	----	----	----	----	----	----	----	----	----	----

Sequence No.

0	1	2	3	4	0	1	...	3	4	0	1	2	3	4
---	---	---	---	---	---	---	-----	---	---	---	---	---	---	---

Updated frame information

10	10	01	01	00	10	10	...	01	00	10	10	01	01	00
----	----	----	----	----	----	----	-----	----	----	----	----	----	----	----

Frame rate: 24PA over 60i (2:3:3:2)

Time code digit

00	01	02	03	04	05	06	...	23	24	25	26	27	28	29
----	----	----	----	----	----	----	-----	----	----	----	----	----	----	----

Video

A0	Ae	B0	Be	Bc	C0	Co	De	Do	De	A0	Ae	B0	Be	Bc	C0	Co	De	Do	De	A0	Ae	B0	Be	Bc	C0	Co	De	Do	De
----	----	----	----	----	----	----	----	----	----	----	----	----	----	----	----	----	----	----	----	----	----	----	----	----	----	----	----	----	----

Sequence No.

0	1	2	3	4	0	1	...	3	4	0	1	2	3	4
---	---	---	---	---	---	---	-----	---	---	---	---	---	---	---

Updated frame information

10	10	01	00	10	10	10	...	00	10	10	10	01	00	10
----	----	----	----	----	----	----	-----	----	----	----	----	----	----	----

Frame rate: 30P over 60i (2:2) 25P over 50i (2:2)

Time code digit

00	01	02	...
----	----	----	-----

Video

A0	Ae	B0	Be	C0	Co	...
----	----	----	----	----	----	-----

Updated frame information

10	10	10	...
----	----	----	-----

720P mode**Frame rate: 24P over 60P (2:3)** Updated frame

Time code digit

00 01 02 03 04 05 06 ... 23 24 25 26 27 28 29

Video

A A B B B C C D D D A A B B ... C D D D A A B B B C C D D D

Updated frame information

10 10 01 01 00 10 10 ... 01 00 10 10 01 01 00

**Frame rate: 30PA over 60P (2:2)
25PA over 50P (2:2)**

Time code digit

00 01 02 ...

Video

A A B B C C ...

Updated frame information

10 10 10 ...

Setting the Time Code

- 1 Switch the menu option TC MODE on the RECORDING SETUP screen to DF or NDF using the menus. (In 59.94 Hz mode)**

For details on menu operation, refer to [Using the menus] (page 116).

- Select DF to advance time code in drop frame mode and NDF in non-drop frame mode. Note that 24P, 24PA and 24PN are always recorded in NDF mode.

- 2 Use the COUNTER button to switch to time code display**

- 3 Position the TCG switch at [SET].**

- 4 Use the CURSOR buttons to set the time code.**

- The time code setting range extends from 00:00:00:00 to 23:59:59:29.

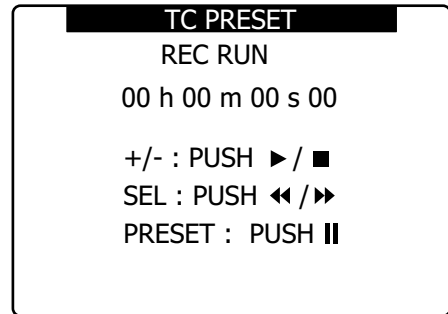

- ▶ button: Shifts the target (highlighted) digit to the right.
- ◀ button: Shifts the target (highlighted) digit to the left.
- ▲ button: Increases the highlighted number by one.
- ▼ button: Decreases the highlighted number by one.
- || (SET) button: Use to confirm set time code value.
- Pressing the RESET button will reset any time code setting to 0.

- 5 Press the SET button to confirm the time code setting, and use the TCG switch to select a time code.**

- [F-RUN] steps the time code in free run mode, and [R-RUN] set it in recording run mode.

<Note>

- When 24P or 24PA is used, the time code is adjusted every 5 frames. Adjust a multiple of four for 24PN, an even number for 30PN and make sure that the seconds plus the frame value makes an even number. The time code cannot be set during recording.
- The set value is not valid if you change the TCG switch position without pressing the SET button.

Time code function during battery replacement

Even during battery replacement the backup mechanism keeps the time code generator functioning.

<Note>

When the POWER switch has been switched ON → OFF → ON, the backup accuracy of the time code in free run mode is about ±2 frames.

Time code in 720P native mode

- At 24PN, recording is performed at 24 frames and output uses a 2:3 pull-down scheme to produce 30 frames.
- At a frame rate (capture frame rate) of 24P the speed of recording and the output time code matches actual time, but not at any speed other than 24P. (Example: at 60P recording progresses at 60/24 speed)
- Then the camera operates in Rec Run mode and the time code output at start of recording matches the recording time code.
- This is also the case for other than 30P capture at 30PN and other than 25P capture at 25PN.

24PN recording at 60P capture

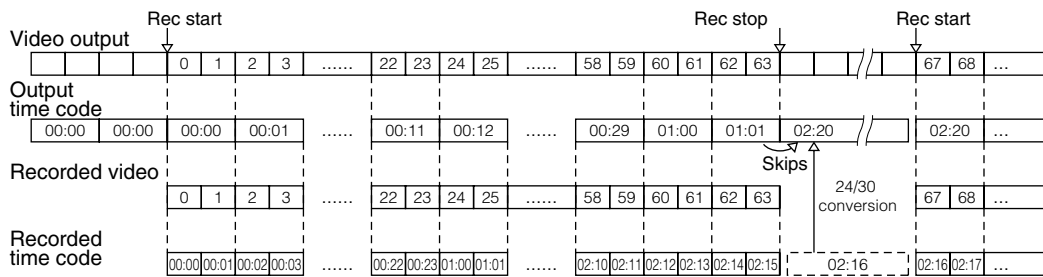

30PN recording at 15P capture

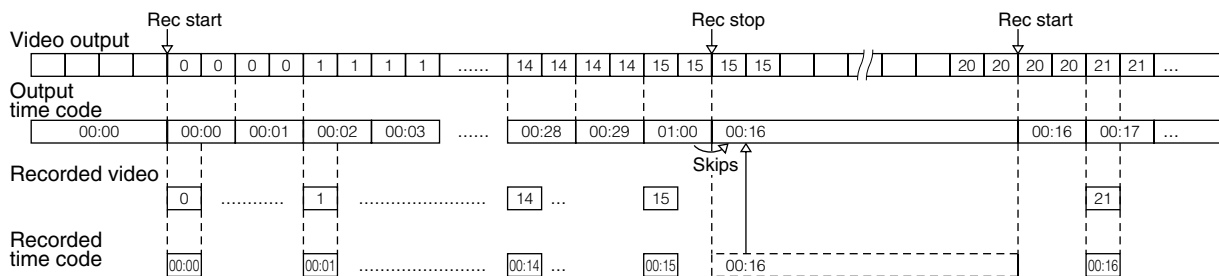

Externally Locking the Time Code

The time code generator built into your AG-HPX500P/E may be locked with an external generator. It is also possible to lock an external time code generator with the internal generator.

Connections for externally locking the time code (examples)

As illustrated, both the reference video signals and the time code must be input.

■ Example 1: Locking the time code with external signals

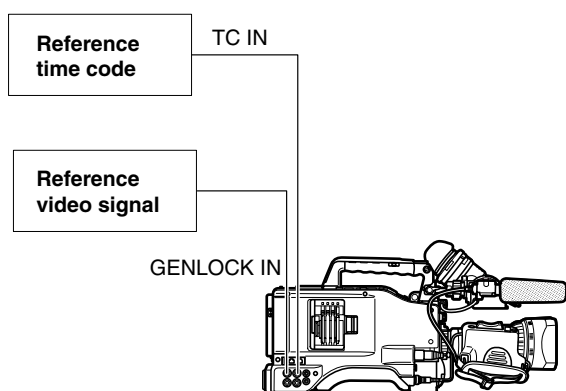

<Note>

- In addition to an HD Y reference signal, a composite video signal can also be input as reference signal.

■ Example 2: Connecting two or more AG-HPX500P/Es with one another, with one being used as the reference device.

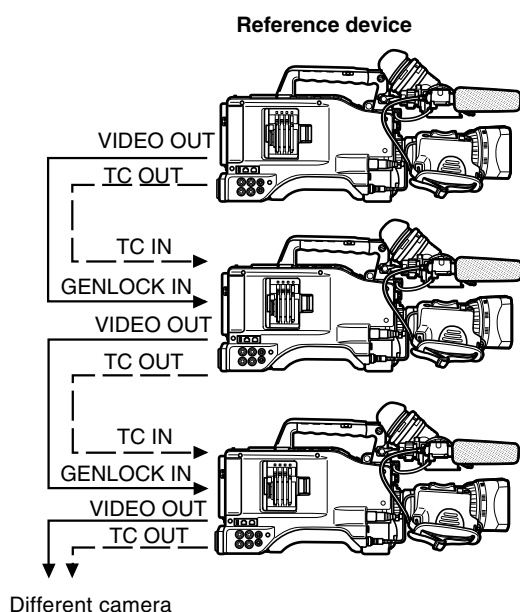

<Note>

- On all connected devices, set the setting menu TC VIDEO SYNCRO (OUTPUT SEL screen) to TC IN, GL SELECT (OTHER FUNCTIONS screen) to COMPOSITE and CMPNT/SDI SEL (OUTPUT SEL screen) to AUTO.
- Setting the setting menu TC VIDEO SYNCRO to TC IN will supply the time code via TC IN to the next slave device without delay.

To externally lock the time code

Follow the steps below.

- 1 Turn on the POWER switch.
- 2 Position the TCG switch at [F-RUN].
- 3 Set the COUNTER button to TC.
- 4 Supply a phase-relationship reference time code (that conforms to the time code requirements) and reference video signals to the TC IN and GENLOCK IN connectors, respectively.

- Now the built-in time code generator is locked with the reference time code.
- When locked to an external time code generator, the time code is at all times locked to the external time code, which is displayed as a highlighted value on the counter indicator. Do not engage the recording mode during the few seconds it takes for the sync generator to stabilize.
- Once a slave relationship is established, the TC IN and GENLOCK IN connectors stay in slave status. Note that the following events release slave status.
 - When TC PRESET is performed
 - When CAMERA mode and MCR mode are switched
 - The power is turned off
 - The time code mode is switched
 - The TCG switch is set to R-RUN
- * The slave function locks the time code to the TC IN input and the device will use this time code even if time code input should subsequently cease.

Setting the user bits when the time code is externally locked

To externally lock user bits, set the setting menu TC IN UB REGEN (RECORDING SETUP screen) to ON. Regardless of an F-RUN or R-RUN setting of the TCG switch, the time code is slaved to user bit values input to the TC IN connector.

For details, refer to [Setting Time Data] (page 58) and [Setting user bits] (page 60).

To unlock the externally locked time code

Discontinue external time code supply, then position the TCG switch at [R-RUN].

Cautions in switching the power source from battery to external power supply

Connect the DC IN socket with the external power supply before removing the battery pack, in order to keep the time code generator energized. If the battery pack is removed first, there is no guarantee that the time code will stay externally locked.

External synchronisation of the camera when the time code is externally locked

When the time code is externally locked, the reference video signals input through the GENLOCK IN connector gen-lock the camera.

<Notes>

- To externally lock the AG-HPX500P/E, as the master device, with more than one unit, the mode must be the same as that of the camera. Note that in a system using both interlaced and progressive scanning, there may be breaks in the video and time code.
- Note that switching to MCR mode will disrupt GENLOCK synchronization resulting in loss of image stability.
- When the 24P or 24PA is selected and the time code is externally locked, be sure to input a non-drop frame time code. The time code cannot be externally locked when drop frame mode is selected. When the time code is externally locked, the video may be distorted, but this is because of the 5-frame adjustment and not a malfunction.

Outputting the time code externally

To output time code from the camera's TC OUT connector to a VTR or other recording device in sync with camera picture or playback picture, set the setting menu TC VIDEO SYNCRO (OUTPUT SEL) to VIDEO OUT.

Set also the setting menu GL SELECT (OTHER FUNCTIONS) to SDI or COMPOSITE to suit video output.

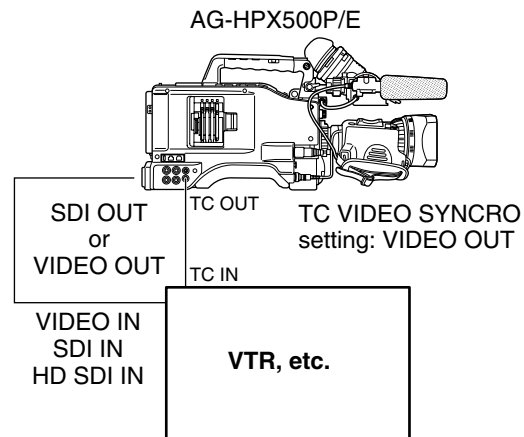

<Note>

When the setting menu TC VIDEO SYNCRO is set to VIDEO OUT, the time code is output via TC OUT in tune with VIDEO OUT delay.

GENLOCK and time code input/output connection and setup

Camera operating conditions			Camera setup		GENLOCK input and camera output phase (In phase: ○ Out of phase: ×)			Connection diagram
Recording format	Video and reference signal to be output externally	GENLOCK input	GL SELECT	GL PHASE	SDI OUT	VIDEO OUT	TC OUT	
1080i	SDI OUT (1080i)	1080i	SDI	Disabled	○	×	○	(1)
	VIDEO OUT		COMPOSITE	OFF	×	○	○	—
			ON		×	▲ 90H delay	▲ 90H delay	
	SDI OUT (1080i)	SD (480i, 576i)	SDI	OFF	○	×	○	(1)
VIDEO OUT	COMPOSITE		ON	▲ 90H advance	×	▲ 90H advance	(2)	
720P	SDI OUT (720P)	SD (480i, 576i)	SDI	Disabled	○	×	○	(1)
	VIDEO OUT		COMPOSITE	ON	▲ 120H advance	×	▲ 120H advance	(2)
	SDI OUT (720P)		SDI	Disabled	○	×	○	(1)
480i, 576i	SDI OUT (480i, 576i)	SD (480i, 576i)	SDI	Disabled	○	×	○	(1)
	VIDEO OUT		COMPOSITE	Disabled	×	○	○	

■ Connection diagram (1)

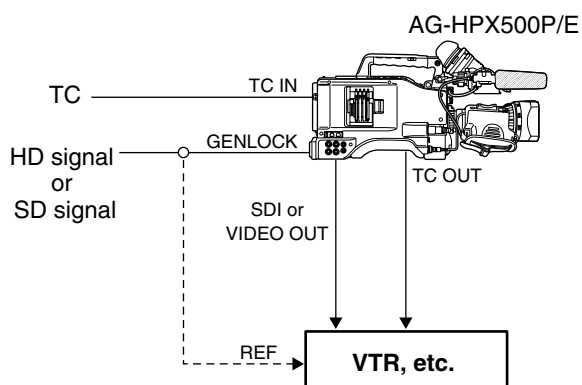

■ Connection diagram (2)

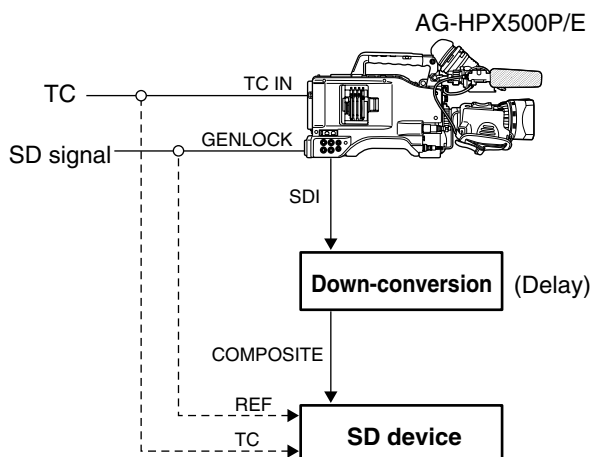

Counter Setting and Display

Pressing the COUNTER button to view the counter displays the counter value on the time code indicator in the LCD and in the viewfinder. The counter value is indicated in “Hour : Minute : Second” format. The counter can display the total recording time but is not displayed during playback. The recording CTL counter value is retained also when P2 cards are replaced and after a power down. At next power up, the counter starts from the value reached at the previous power down.

<Note>

- Pressing the RESET button when the counter value is displayed resets the counter to 0.
- The counter value indicates values in the range between 0:00:00 and 9:59:59 at 1-second step.

Viewfinder Screen Status Displays

In addition to video images, the viewfinder displays lamps and text that indicate the settings and operating status of the AG-HPX500P/E, together with messages, a center marker, a safety zone marker and the camera ID.

Lamps in the Viewfinder Screen

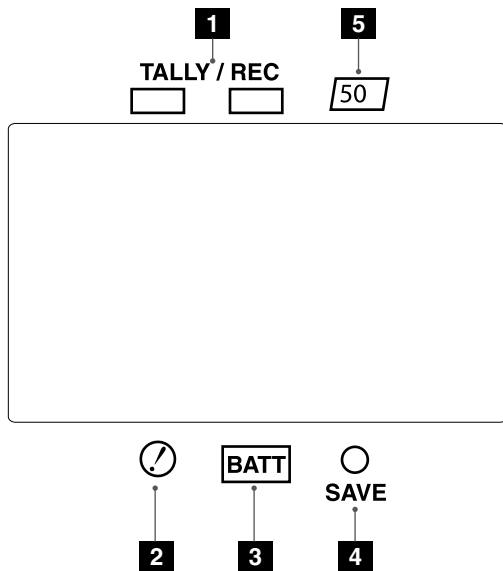

The illustration above shows the supplied viewfinder and the optional AG-VF11G viewfinder, which is equivalent to the supplied one. When using a viewfinder other than these two viewfinders, see the Operating Instructions provided with that viewfinder.

- 1 TALLY/REC (recording) Lamp**
This lamp stays illuminated during recording, and starts blinking if any abnormal action occurs. For more information, see [Warning System] (page 142).
- 2 Abnormal Operating Status Warning Lamp**
This lamp comes on when this unit is in any of the abnormal operating statuses specified through the menu options in the VF ! LED screen. For statuses that activate the lamp, see the option in the section [VF ! LED screen] (page 126).

- 3 BATT (battery) Lamp**
This lamp starts blinking a few minutes before the battery charge starts to run out, and stays illuminated after the battery is completely flat. The battery should be replaced before it is nearly flat, so that operation will not be interrupted. For more information, see [Warning System] (page 142).
- 4 SAVE Lamp**
This lamp lights when the SAVE switch is set to ON and the LCD is off.
- 5 50M indication lamp**
Not used on this camera.

Viewfinder Status Indication Layout

The indications are arranged as illustrated below.

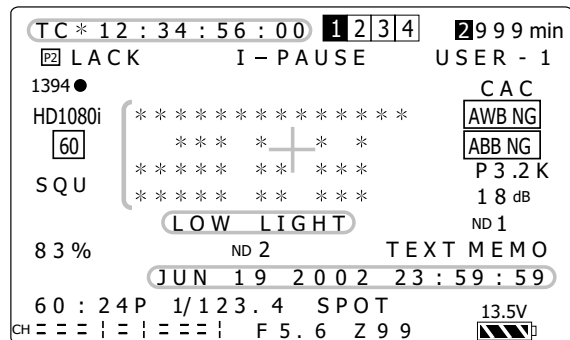

For more information, see the following pages:

Selecting Viewfinder Display Information

To select items in the viewfinder screen, open the DISPLAY SETUP screen and turn on or off each item or type. Refer to the section [Using the menus] (page 116).

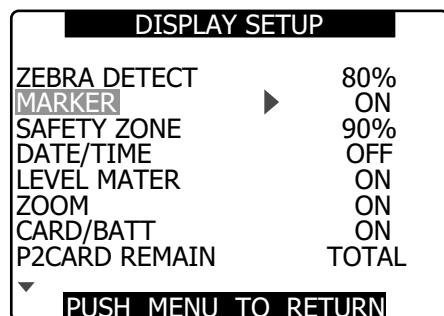

Screen displays

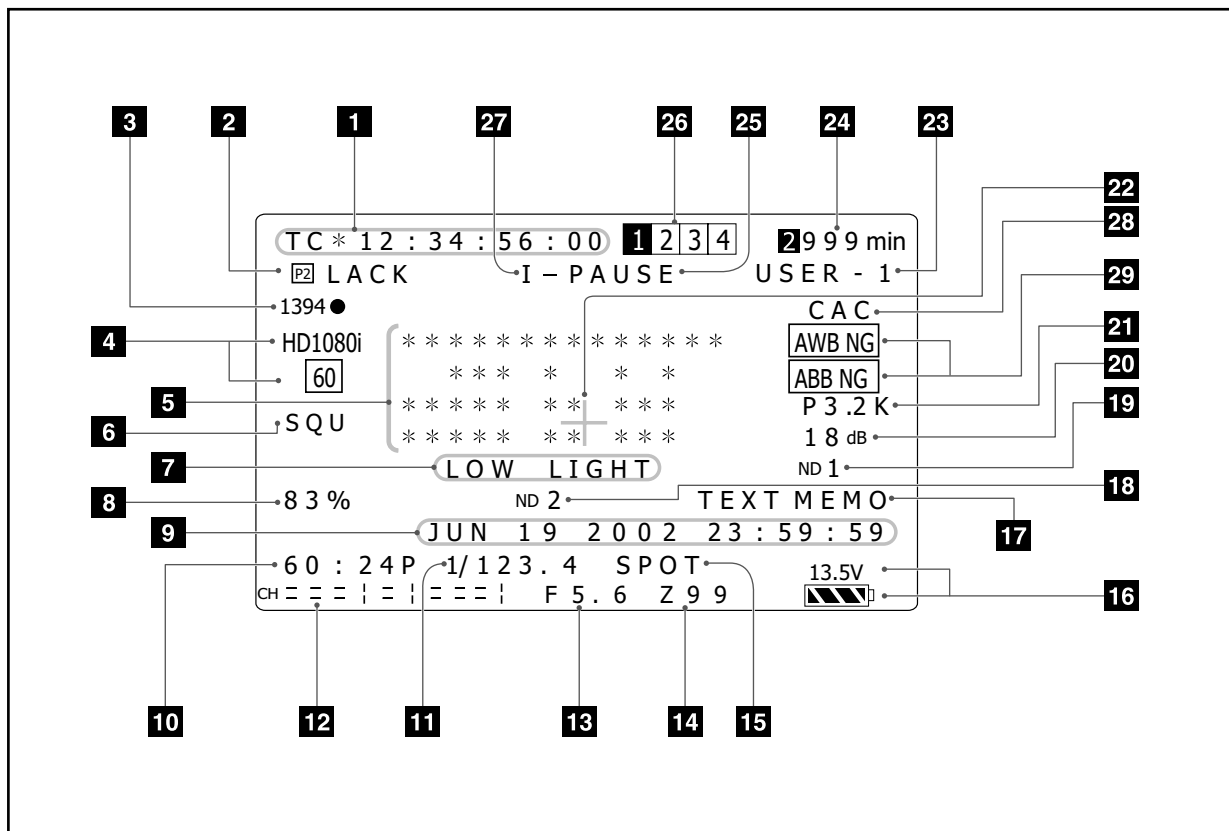

1 Time code displays

Each time you press the COUNTER button, the display switches over to the following data (or no indication).

- **No indication**
- **Counter:** Counter value (only in recording mode)
- **TC:** Time code value
“TC*” is displayed when the time code value cannot be correctly read from 1394 connector input.
The colon (:) between the seconds and the frames changes to a period (.) in drop frame mode.
- **tc:** Time code value (frame digits are indicated in 24/30 frame conversion: 59.94 Hz FILM CAM only)
“tc*” is indicated when the time code value cannot be correctly read from 1394 connector input.
The colon (:) between the seconds and the frames changes to a period (.) in drop frame mode.
- **UB:** User bit value
“UB*” is indicated when the user bit value cannot be correctly read from 1394 connector input.
- **FR:** Frame rate information for recording
 - FR 60I: 60i interlace mode (60 fields/sec.)
 - FR 60P: 60P progressive mode (60 frames/sec.)
 - FR 30P: 30P progressive mode (30 frames/sec.)

- FR 24P: 24P progressive mode (24 frames/sec.)
- FR24PA: 24P advanced mode (24 frames/sec.)
- FR50I: 50i interlace mode (50 fields/sec.)
- FR50P: 50P progressive mode (50 frames/sec.)
- FR25P: 25P progressive mode (25 frames/sec.)

In FR24P and FR24PA modes, the last digit indicates the frame conversion sequence information.

<Note>



When TC, tc and UB are locked to the TC IN input, white characters over a background (TC → TC) appear.

When the HOLD button is used to temporarily stop the indication, the HOLD indication blinks.

2 Warnings

- Flashes when no P2 card is inserted or the card is write protected.
- **FULL:** Blinks when there is no remaining capacity in the P2 card.
- **LACK:** Blinks in the loop rec mode when the remaining capacity of the P2 card is insufficient.
- Lights when the battery for the internal clock is depleted.

16 Remaining battery charge

As the remaining battery charge drops, the display changes as follows:  When the battery has completely discharged,  () blinks.

(When the AC adapter is being used, a display other than  may appear: this is not a sign of malfunctioning.)

- **13.5V:** Battery voltage indication
Indicates the current voltage for analog batteries.
- **XX%:** 10% to 99%
Indicates the remaining battery level in % for digital batteries.
This value is not indicated on the meter.
- **MAX:** Indicates that a digital battery is fully charged.
- **EMP:** Indicates that a digital battery has a remaining charge of less than 10%.
- Battery type indication
Holding down the DISP/MODE CHK button will show the value currently set for battery remaining level indication.
“AC ADPT” is shown when the AC adapter is used.

17 Text memo and shot mark indicator

- This indicator lights when text memos are inserted during recording or playback by pressing the USER button to which the TEXT MEMO function has been assigned.
- “MARK ON” appears when shot marks are inserted during recording by pressing the USER button to which the SHOT MARK function has been assigned.
A second press will delete the shot mark and MARK OFF appears.
- “INVALID” appears when a text memo could not be entered or a shot mark could not be recorded or deleted.

18 Recommended ND filter

The recommended ND filter under the current shooting conditions is displayed here.

19 ND filter display

- ND filter selected is displayed.
- An “ND –” indication means that the ND FILTER switch is incorrectly set (a position other than ND1 to ND4). Check ND FILTER switch position.

20 Gain display

Displays the gain value of the image amplifier configured.

21 WHITE BAL switch position indication

Indicates the switch position currently selected. Also indicates white balance operation when AWB is set to “preset”.

22 Center marker display

Markers are displayed when the MARKER item in the setting menu DISPLAY SETUP screen is set to ON.

23 Scene file name display

Indicates name of SCENE FILE (F1 to F6).

24 Media remaining memory display

- Setting the setting menu P2 CARD REMAIN (DISPLAY SETUP) to ONE-CARD displays the remaining time on the P2 card that is currently being recorded and the number of the slot it resides in. Setting P2 CARD REMAIN to TOTAL displays the remaining time on all four cards.
- In a mode check, “ONE-CARD” and “TOTAL” are alternately displayed.
- There is no display while the remaining memory is being calculated. “LOOP” is displayed during Loop recording (LOOP REC).
- In a mode check during loop recording, the minimum guaranteed available recording time is displayed.
- Indicates remaining time in 1-minute increments from 0 to 999 minutes.
- The display blinks when 2 minutes or less time is left.

25 Operational state display

- **REC:** Recording
- **PAUSE:** Recording pause
- **II:** Play pause
- **▶ (◀):** Play (reverse play)
- **▶▶ (◀◀):** Fast-forward/Fast-forward play (Rewind/Fast-backward play)
- **▶▶ (◀◀):** Slow play (Reverse slow play)
- **CHK:** Rec check
- **III (III▶):** Frame-by-frame (Reverse Frame-by-frame)
- **x ▶ / x ▶▶ (x ◀ / x ◀◀):** Variable-speed search (Reverse variable-speed search)
- **CLIP III▶ (CLIP III ◀):** Clip forward (Clip reverse)
Cue up of single clips

Not displayed when the LCD is off in CAMERA mode. (But displayed when pre-recording, interval recording or one-shot recording is set.)

26 Media information display

The card slot where the P2 card was inserted and the basic information of the media are displayed here.

- **1 lights:** P2 card on which data can be recorded.
- **1 lights green:** P2 card on which data is to be recorded.
- **1 Flashes:** Card recognition underway, or a card other than that on which data is to be recorded in special recording mode
-  : No card inserted.
- **P** : Write-protected
- **F** : Full memory
- **X** : Cannot recognize
- **E** : a P2 card in an invalid format (Returns to normal if formatted.)

27 Special recording display

This display appears when the REC FUNCTION option of the setting menu RECORDING SETUP screen is set to INTERVAL, ONE SHOT or LOOP, and when PRE REC is set to ON.

A P2 card inserted in a free slot after start of a special recording mode is not used for recording. Insert P2 cards before start of recording. Stop special recording and insert the P2 card again.

28 Lens chromatic aberration compensation (CAC) indicator

During a mode check, it indicates that lens chromatic aberration compensation (CAC) operates normally.

29 AWB, ABB error indication

In a mode check, the status of AWB and ABB that do not operate normally is shown.

■ Safety zone

The range of the zone is indicated by the SAFETY ZONE item on the DISPLAY SETUP screen.

• 4:3: 

This indicates the position which is cropped to 4:3.

• 90%: 

This indicates the range (90%) in which signals can be displayed by an ordinary home-use TV set.

Warnings**• COPY INHIBITED**

Input of DV formats via the 1394 connector in MCR mode cannot be recorded normally since the contents are copyright protected.

• EXTERNAL 1394 DISCONNECT

When the 1394 CONTROL item of the OTHER FUNCTIONS screen of the setup menu is set to EXT and recording without connecting external units with 1394 terminal, this display appears.

• INCOMPATIBLE CARD

The card cannot be used since it does not comply with the specified standard.

• DIR ENTRY NG CARD

The directory structure on the P2 card is not supported.

Operation continues. However, recording or playback may not operate correctly.

The P2 card cannot be used for the special recording functions (interval recording, one-shot recording, and loop recording).

Back up data on the P2 card as soon as possible, and format the card before using it again.

• RUN DOWN CARD

The maximum number of overwrites on the P2 card has been exceeded.

Operation continues. However, recording or playback may not operate correctly. It is recommended that you replace the P2 card with another one.

• FORMAT ERR !

Indicates a P2 card that does not meet the P2 card standard.

<Thumbnail operations>**• CANNOT ACCESS**

Cannot access clips.

• CANNOT DELETE

Cannot delete clips.

• CANNOT FORMAT

Cannot format P2 cards or SD memory cards.

• CANNOT REPAIR

Cannot repair clips.

• CARD FULL

The P2 card does not have enough free space for recording.

• WRITE PROTECTED

The P2 card or SD memory card is writeprotected.

• NO CARD

A P2 card or SD memory card has not been inserted.

• NO FILE

There are no files (version upgrade files, etc.).

P2 card playback data indication

• **EOS:** End of stream. No more data is available in the forward playback direction.

• **BOS:** Beginning of stream. No more data is available in the rearward playback direction.

• **P2 SLOT:** Appears when pressing the USER button to which SLOT SEL is assigned.

Errors

These are displayed when an error occurs in the unit, P2 card, tape, or other component. If the problem is not fixed by turning the power off and then on again, either replace the card or tape based on the error information, or consult with your dealer as to which one is to be purchased.

- **CANNOT REC**

This is displayed during a recording error.

- **CANNOT PLAY**

This is displayed when trouble has occurred during playback.

- **CARD ERR (1) (2) (3) (4) (1/2/3/4):**

Trouble has occurred in the P2 card found in the slot indicated by the number.

- **CLIP ERROR:** clip trouble

- **UPDATING:** Reading card data

- **ERROR:** other type of trouble

- **SYSTEM ERROR**

This is displayed when trouble has occurred in the system. Switch ON the power again.

- **P2 MICON ERROR:** No P2 microcomputer response

- **P2 CONTROL ERROR:** Trouble in P2 control

- **REC RAM OVERFLOW:** Recording RAM overflow

- **TURN POWER OFF**

This message indicates that an abnormal event has occurred, for example, that a card has been removed during access or that a change in system frequency has been made. Turn the power off and then turn it back on again.

- **REC WARNING**

This is displayed when trouble has occurred during recording. Carry out recording once again. If the warning persists, consult your dealer.

- **CARD ERR (1) (2) (3) (4) (1/2/3/4):**

Trouble has occurred in the P2 card found in the slot indicated by the number.

- If the warning continues, turn off the power.

- If the warning appears even when recording is carried out again, replace the card with another one.

- **ERROR:** Other type of trouble

- **1394**

This is displayed when trouble has occurred in the 1394 connections or signals.

- **1394 INITIAL ERROR:** Connection error

- **1394 INPUT ERROR:** Input error

- **1394 INPUT ERROR (OTHER FORMAT):**

(Wrong input format)

- **LOW BATTERY:**

Indicates that the battery is exhausted.

Camera status display

- **AWB:** AWB indicator

- **ABB:** ABB indicator

- **AWB P3.2 K/AWB P5.6K:** Displays the color temperature assigned to PRST when the WHITE BAL switch is set to PRST. Also displayed when AWB is performed in the PRST position.

- **GAIN **dB:** Displayed when GAIN is switched.

- **BACK LIGHT (OFF):** Displayed during iris control when back light status is changed by pressing the user button to which BACK LIGHT is assigned.

- **SPOT LIGHT (OFF):** Displayed during iris control when back light status is changed by pressing the user button to which SPOT LIGHT is assigned.

- **SHUTTER 1/**** (OFF):** Displayed when the shutter speed is changed.

- **SCENE *****:** Displays the name of a scene file selected by turning the SCENE FILE dial.

- **ND NG:** Displayed when the ND filter is not working normally.

- **AUTO KNEE (ON/OFF):** Displayed when changing the AUTO KNEE switch position.

USER buttons assignment information (at mode check)

Displays the function assigned to each USER button. For details, see [Assigning Functions to USER buttons] (page 55).

! LED light indication (at mode check)

Indicates why an ! LED is lit according to setting menu VF! LED screen settings.

- **GAIN:** Indicates the camera is using a gain value other than 0 dB.

- **AWB:** Indicates that the WHITE BAL switch is set to PRST.

- **SHUT:** Indicates the electronic shutter is operating.

- **FILT:** Appears when the filter set by menu is met.

- **EXT:** Indicates when the lens extender is inserted.

Checking and displaying shooting status

- Hold down the DISP/MODE CHK button in recording standby or during recording to display the settings of each shooting function, the list of functions assigned to USER buttons and all other information. Press again to return to the regular screen.
- Press the DISP/MODE CHK button during recording standby or recording clears all displays. Press again to return to the regular display.
- These settings are maintained when the unit is turned off and also when switching media and operating mode.
- Display the following items on the viewfinder and LCD monitor screen by pressing the DISP/MODE CHK button or by configuring OTHER DISPLAY of the DISPLAY SETUP screen of the setup menus.

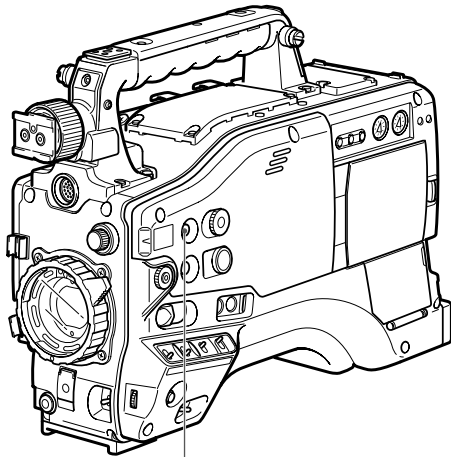

DISP/MODE CHK button

	Displays	MODE CHECK	DISPLAY	Audio dubbing mode		
				ALL	PARTIAL	OFF
1	Time code display	○	—	—	—	—
3	Backup unit display	—	×	○	○	○
4	Recording format and system frequency indication	○	○	○	×	×
5	Information display	○	—	—	—	—
6	Squeeze information	○	○	○	○	×
8	Marker luminance display	○	○	—	—	—
9	Calendar	○	○	—	—	—
10	Recording/playback frame rate display	○	○	○* ₁	×	×
11	Shutter speed	○	○	○	○	×
12	Audio level meter display	○	○	—	—	—
13	IRIS display	○	○	○	○	×
14	Zoom position display	○	○	—	—	—
15	Auto-iris control display	○	○	○	○	×
16	Remaining battery charge	○	○* ₄	—	—	—
18	Recommended ND filter	○	○	○	○	×
19	ND filter display	○	○	○	×	×
20	Gain display	○	○	○	○* ₂	×
21	WHITE BAL switch position indication	○	○	○	○* ₃	×
22	Center marker display	○	×	—	—	—
23	Scene file name display	○	○	○	×	×
24	Media remaining memory display	○	○* ₄	—	—	—
25	Operating status display	○	○	—	—	—
26	Media information display	○	○	—	—	—
27	Special recording display	○	○	—	—	—
28	Lens chromatic aberration compensation (CAC) indicator	○	—	×	×	×
29	AWB, ABB error indication	○	×	×	×	×
	Safety zone display	—	×	—	—	—

○: Displayed

×: Not displayed

—: Displayed depending on other settings

The item in ○ in the MODE CHECK space appears when you press and hold the DISP/MODE CHK button.

The item in ○ in the DISPLAY space disappears when you press the DISP/MODE CHK button.

*₁ Not displayed when FRAME RATE is set to 60i or 50i.

*₂ 0 dB is not displayed.

*₃ Only preset 3.2K and 5.6K are displayed.

*₄ Blinks when there is little remaining time left.

Setting the Marker Displays

Turn marker display on or off.
Select the display mode from the setting menu
DISPLAY SETUP screen.
For directions on navigating the menu, see [Using the
menus] (page 116).

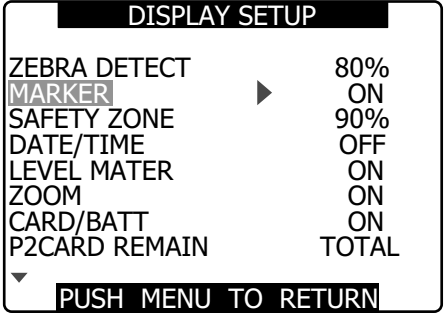

You can also press the USER button to which the
MARKER function has been assigned to turn the
marker on and off.

Adjusting and setting the LCD monitor

Using the LCD Monitor

- 1** Turn on the POWER switch of the AG-HPX500P/E.
- 2** Slide the OPEN button in the arrow ① direction to open the LCD monitor.

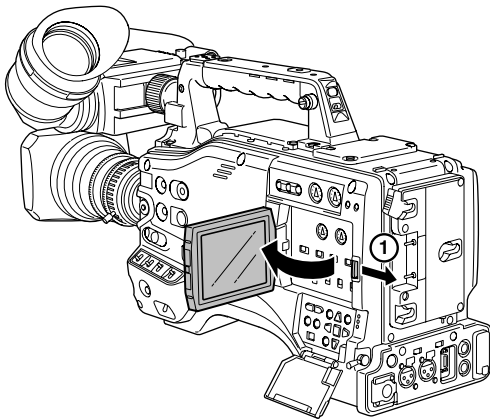

<Note>
The LCD monitor opens to an angle of 120 degrees. Attempts to open it further will damage the monitor.

- 3** Adjust the angle of the LCD monitor for most convenient viewing.

- The monitor can turn up to 180 degrees towards the lens and up to 90 degrees towards you.

<Note>
To prevent camera-recorder failure, do not allow undue force to be applied to the monitor (when it is open).

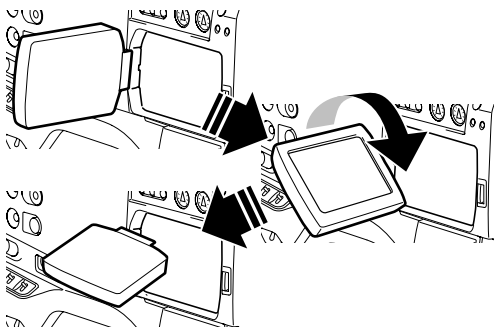

- 4** Use the menu option LCD SET (DISPLAY SETUP) to adjust the brightness, color level and contrast of the screen.

For details on menu operation, refer to [Using the menus] (page 116).

- At LCD SET of the DISPLAY SETUP screen, select YES.

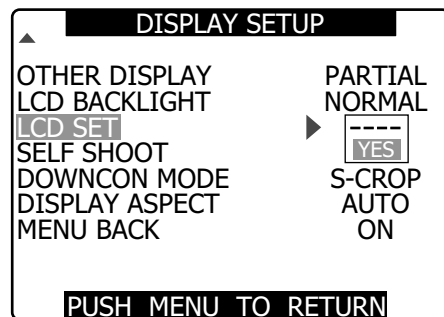

- 5** Use the JOG dial button to select an item.

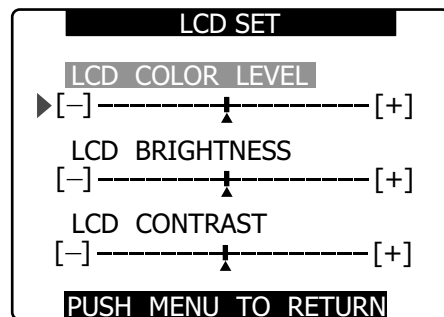

- 6** Press the JOG dial button, and turn the JOG dial button to adjust the selected item.

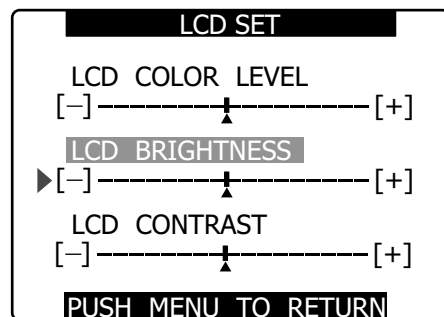

<Note>

- Pressing the RESET button when a value that can be adjusted is selected in the setting menu LCD SET will return the setting to its factory default.
- When closing the LCD monitor make sure that it is shut tight.
- In an environment with sudden temperature changes, condensation may form on the liquid crystal surface of the monitor. If this happens, wipe off the moisture with a soft, dry cloth.
- When the camera-recorder is very cold, the video image in the LCD monitor will appear slightly darker immediately after the power is turned on. Once the interior of the camera-recorder warms up, the LCD monitor delivers normal brightness.
- When the SAVE switch is set to ON, the LCD monitor is forcibly disabled.

Self-portrait Shooting

When shooting with the LCD display angled 180 degrees towards the lens, you can set the menu option SELF SHOOT to MIRROR, to horizontally flip the video image on the LCD display, and allow you to view a mirror image while shooting.

Note that only the video image on the LCD monitor is horizontally flipped, not the actual video being recorded.

The menu option SELF SHOOT can be found in the DISPLAY SETUP screen.

Handling setup data

Configuration of setup data files

This camera makes it possible to save a scene file to each of the F1 to F6 positions on the SCENE FILE dial. Use of an SD memory card makes it possible to save up to four of the F1 to F6 files on an SD card for later retrieval.

The setting menu values can be stored as a user file in the camera and up to four files can be stored on the SD memory card.

The setting data files are configured as shown below.

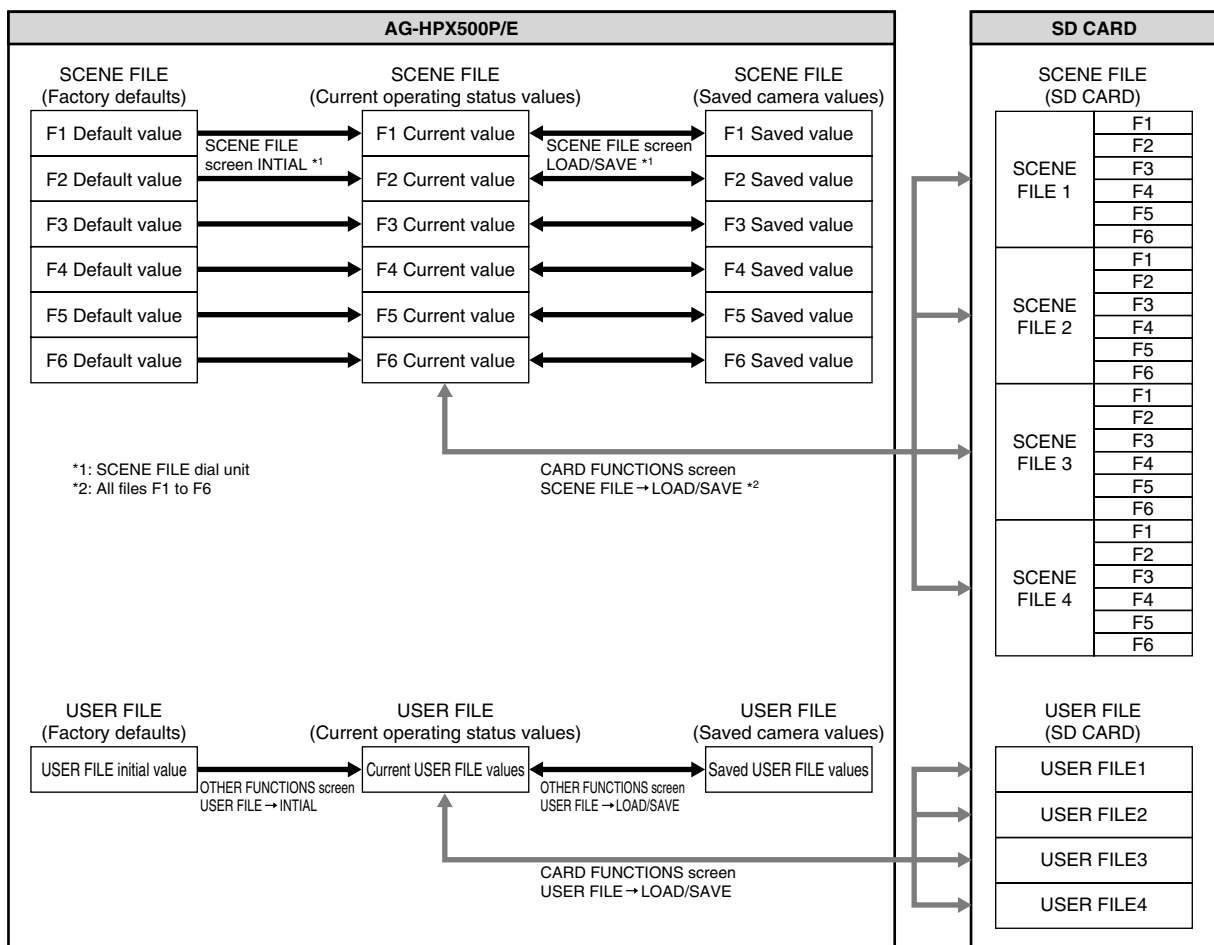

Setting Data Using an SD memory card

An SD or SDHC memory card (optional accessory) can be used as a setup card that stores up to four files of settings menu specifications.

This data allows you to quickly reproduce an optimum state.

See [Memory Card Usage] (page 83).

Handling SD memory cards

An SD memory card may be inserted or removed, either before or after the power is turned on.

To insert an SD memory card

Open the lid of the switch cover, and insert an SD memory card (optional accessory) into the SD memory card slot with the notch upward. Close the lid.

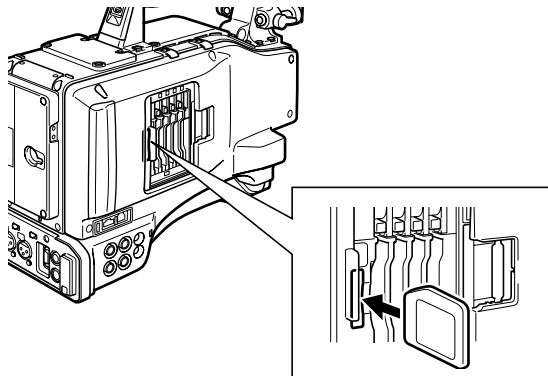

<Note>

An SD memory card must be inserted with the right side facing the slot. If the card is hard to insert, it may be reversed or upside down. Do not force it into the slot. Check the card before reinserting it.

To remove the SD memory card

Open the lid of the switch cover, and ensure that the BUSY lamp is not illuminated. Then, further depress the SD memory card towards the main unit. This releases the SD memory card from the insertion slot. Take hold of the SD memory card and remove it. Close the lid.

SD memory cards must not be used or stored in an environment where they may be

- Exposed to high temperatures/humidities;
- Exposed to water droplets; or
- Electrically charged.

For storage, the SD memory card must be kept inserted into the AG-HPX500P/E with the lid closed.

Formatting, Writing and Reading an SD memory card

Open the CARD FUNCTIONS screen from the setting menu to format SD memory cards, write setting data to SD memory cards and to read data stored on an SD memory card.

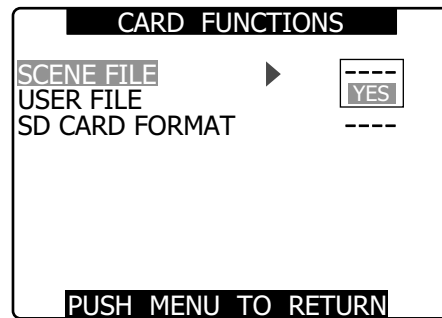

For an SD memory card formatted with a device that does not support SD/SDHC standards, the message "FORMAT ERROR" appears at the upper right of the screen. In this case, reformat the card as follows. See [To format an SD memory card] (page 78).

To format an SD memory card

<Note>

SD memory cards may be formatted via the thumbnail screen. For more information, see [Formatting SD memory cards] (page 112).

- 1 Navigate the menu to the <CARD FUNCTIONS> screen.
For details on menu operation, refer to [Using the menus] (page 116).
- 2 Turn the JOG dial button to move the cursor to the menu option SD CARD FORMAT.
- 3 Press the JOG dial button.

4 To format the SD memory card, turn the **JOG dial button** to move the cursor to **YES**. Then, press the dial button.

- “SD CARD FORMAT OK” appears and the SD memory card is formatted.

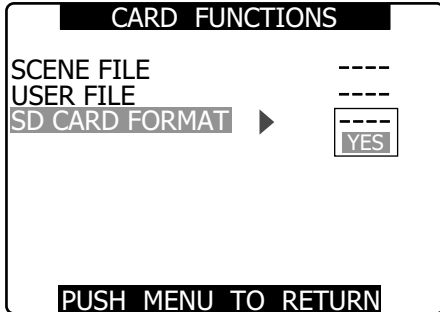

The card will not be formatted if the following message appears when the JOG dial button is pressed:

Error message	Remedy
SD CARD FORMAT NG NO CARD (No SD memory card inserted.)	Insert an SD memory card.
SD CARD FORMAT NG ERROR (SD memory card cannot be formatted.)	The card may be defective. Replace the card.
SD CARD FORMAT NG WRITE PROTECT (SD memory card is write-protected.)	Remove the card and cancel the protect.
SD CARD FORMAT NG CANNOT ACCESS (SD memory card not accessible).	The SD memory card is not accessible. When the current access operation ends, reformat the card.

How to Use Scene File Data

- The settings according to the variety of shooting circumstances are stored in each position of scene file dial.
- When shooting, you can retrieve the necessary file instantly using scene file dial.
- You can also use menu options to change set scene file values. A modified scene file can be saved to each scene file dial position.

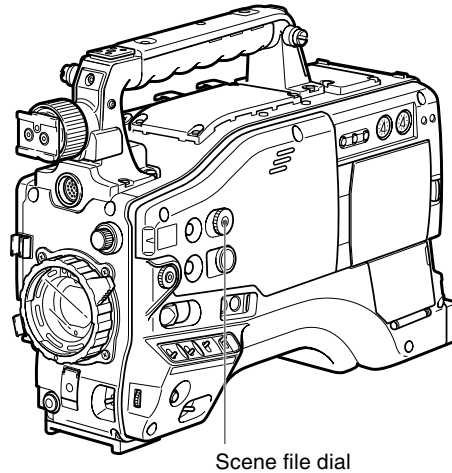

- During recording, the OPERATION TYPE and FRAME RATE settings remain unchanged even when the scene file is changed. To change these settings, set the camera-recorder to recording standby state.

■ Factory setting

- **F1: SCENE**
File suitable for normal shooting.
- **F2: SCENE FLUO.**
File suitable for shooting under fluorescent lights, ie. indoors.
- **F3: SCENE SPARK**
File suitable for SD shooting with fuller variations of resolution, coloring and contrast.
- **F4: SCENE B-STR**
File for broadening the contrast of dark parts, such as when shooting sunsets.
- **F5: SCENE CINE V**
File suitable for shooting movie-like scenes where the contrast is to be emphasized. (The recording format remains unchanged even when the scene file is changed. It must be set using the REC FORMAT option on the RECORDING SETUP screen.)
- **F6: SCENE CINE D**
File suitable for shooting movie-like scenes where the dynamic range is to be emphasized. (The recording format remains unchanged even when the scene file is changed. It must be set using the REC FORMAT option on the RECORDING SETUP screen.)

Changing scene file settings

■ **Example1:** Change the name of the scene file.

1 Turn the scene file dial, then select the scene file to be changed.

2 In the setup menus, open the SCENE FILE screen.

3 Turn the JOG dial button to move the cursor to the option NAME EDIT. Then, press the JOG dial button.

For details on menu operation, refer to [Using the menus] (page 116).

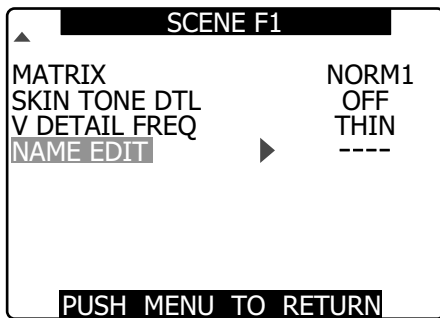

4 Turn the JOG dial button to move the cursor to YES. Then, press the JOG dial button.

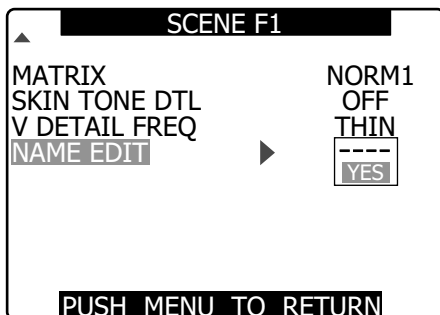

5 When the screen shown below appears, use the JOG dial button to enter a 6-character file name.

- Turning the JOG dial button changes the character display in the following order: space (□) → alphabet (A to Z) → numerics (0 to 9) → symbols (; : < = > ? @ [\] ^ _ . /).
- If the RESET button is pressed when the filename has been set, the characters are cleared.

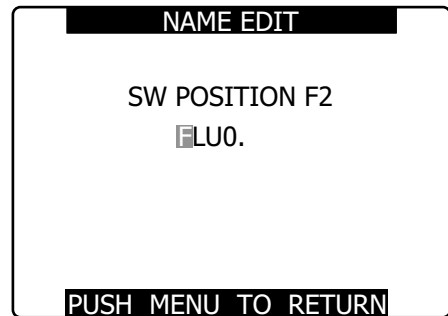

6 After you finish setting the filename, press the MENU button.

- This completes the NAME EDIT change. A change that has been confirmed is retained after a power down and is not affected by dial position. Items set for the scene file are also retained.

■Example2: Save the F1 scene file to the camera.

1 Turn the JOG dial button to move the cursor to the option **LOAD/SAVE/INT.** Then, press the JOG dial button.

For details on menu operation, refer to [Using the menus] (page 116).

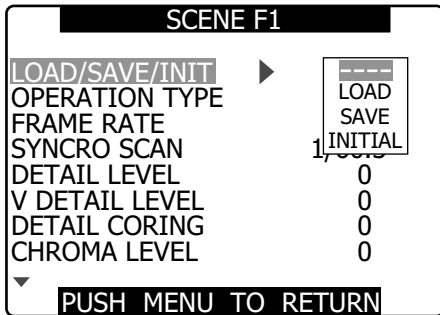

2 Turn the JOG dial button to move the cursor to the option **SAVE.** Then, press the JOG dial button.

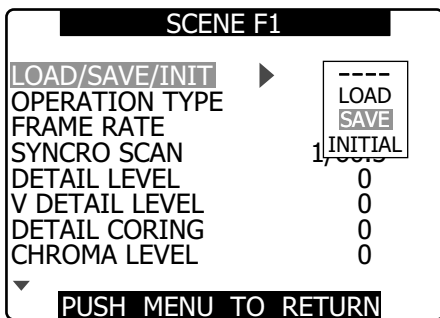

3 Turn the JOG dial button to move the cursor to **YES.** Then, press the dial button.

- To return to the menu level above, press the MENU button.

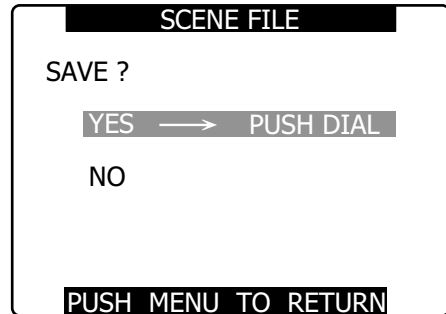

- “PROCESSING” appears and the following message is shown when all settings have been completed.



- After changing the scene file settings, to return to the settings to the previously saved values, select **LOAD** in step 2 and perform the operation described in step 3.
- To return the scene file settings to their factory defaults, select **INITIAL** in step 2 and perform the operation described in step 3.
- To save and read user file settings or return them to their factory defaults, open the setting menu **OTHER FUNCTIONS** screen and run **USER FILE** in the same way as when handling scene files.

Saving scene files and other settings on SD memory cards

You can save up to four scene file settings or other settings as files on an SD memory card, and you can also load them from the card.

- In the case of the scene files, the current settings are automatically saved in the unit, and the saved data is written on an SD memory card. When data has been read from an SD memory card, the current settings are rewritten at the same time as the data saved inside the unit.
- The data in all the scene files, F1 to F6, is rewritten.

The following procedure shows how to save scene files.

1 Set the unit's POWER switch to ON.

2 Select SCENE FILE on the setting menu CARD FUNCTIONS screen, select YES, and press the JOG dial button.

For details on menu operation, refer to [Using the menus] (page 116).

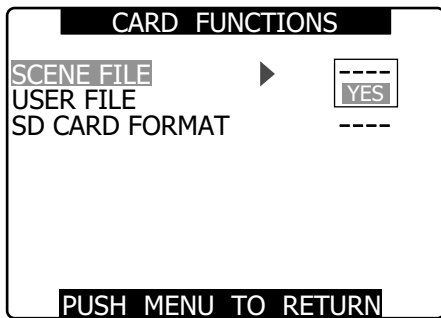

3 Select the file number (1 to 4) using the JOG dial button.

- Press the JOG dial button again to confirm the setting.

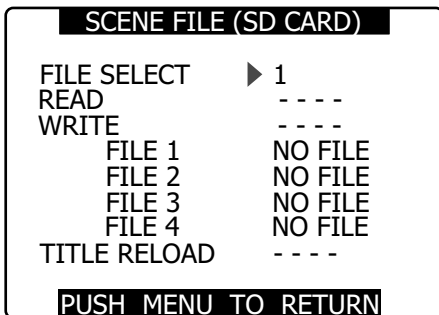

4 Select WRITE using the JOG dial button, and press the JOG dial button.

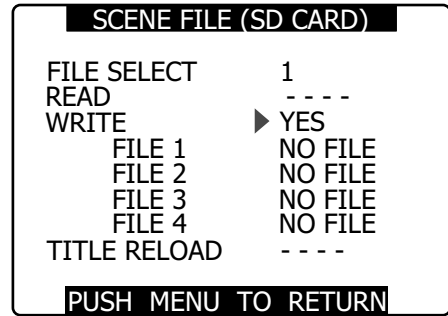

5 Press the ← cursor button, turn the JOG dial button to move to YES and again press the JOG dial button.

- In the following example, TITLE 1 is the filename.
- When writing is completed, WRITE OK appears.

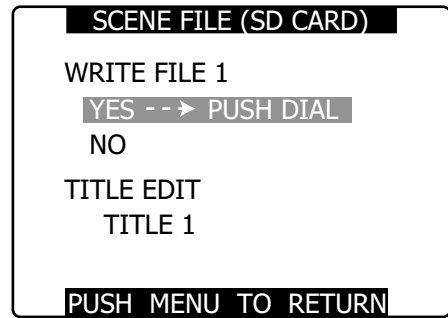

To load a file

Perform steps 1 to 3, select READ in step 4, and press the JOG dial button.

When reading is completed, READ OK appears.

Select USER FILE in the CARD FUNCTION screen and process it in the same way as scene files.

Reloading Files From an SD Memory Card

Perform steps 1 and 2, move to TITLE RELOAD so that YES is displayed in step 4, and press the JOG dial button.

The file is reloaded.

To title a file

- 1 Perform steps 1 to 4.
- 2 Use the JOG dial button to select characters, then press the JOG dial button to move to the next character.
 - You can input any of the following characters: Space, A to Z, 0 to 9, ; ; < = > ? @ [\] ^ _ - . /
 - You can erase all characters using the RESET button.
- 3 When all inputs are completed, press the ◀ cursor button at the left edge of the characters (or press the ▶ cursor button at the right edge or use the JOG dial button).
- 4 Turn the JOG dial button to select YES and press the JOG dial button.

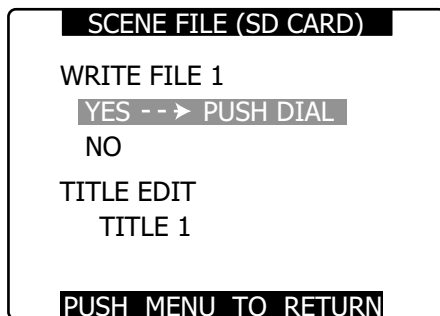

- "WRITE OK" appears when the title is written.

<Note>

- If WRITE NG FORMAT ERROR appears, format the SD memory card.
- If WRITE NG WRITE PROTECT appears, release the protected status of the SD memory card.
- If WRITE NG CANNOT ACCESS appears, quit all other operations (such as playback) before proceeding.
- If WRITE NG ERROR appears, the SD memory card may be defective. Replace it.

Memory Card Usage

Use only cards that conform to the SD card standard or the SDHC standard in this camera.

Be sure to use a mini SD card adapter when using mini SD cards. (The camera will not operate normally when only the adapter is inserted, but be sure to insert a memory card in the adapter.)

■Memory cards that can be used

- SD memory cards (including mini SD cards)
- SDHC memory cards



Use of Panasonic SD/SDHC memory cards and mini SD cards is recommended.

The latest information on memory cards that can be used in the camera is provided at our P2 Support Web site. See below.

<http://pro-av.panasonic.net/>

<Note>

- The SDHC (SD High Capacity) card is a new standard, established by the SD Card Association in 2006, for large-scale memory cards with capacities above 2 GB.

■Cards that cannot be used

Memory cards other than those mentioned above.

- Multimedia cards



Chapter 5 Preparation

Power Supply

A battery pack or an external DC power supply can be used as the power supply for the camera-recorder.

Using a Battery Pack

Battery packs from the following manufacturers can be used:

- Anton/Bauer
- IDX
- PACO
- Sony

<Notes>

- Other batteries may be used by changing the menu setting, but system compatibility is not guaranteed.
- Charge the battery pack with the battery charger before using it. (Please refer to the battery charger's instruction manual for information about charging.)

Mounting the Battery and Setting the Battery Type

Using an Anton/Bauer Battery Pack

1 Mount an Anton/Bauer battery pack.

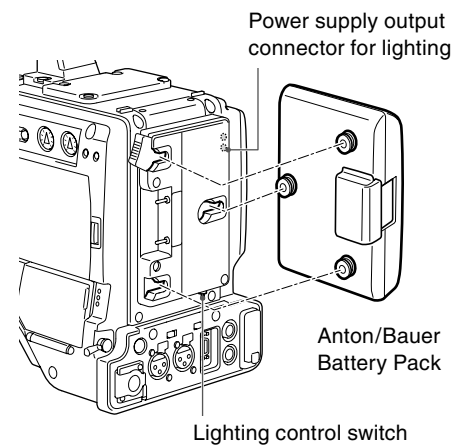

<Note>

The Anton/Bauer battery holder includes both a power supply output connector for lighting and a lighting control switch, which are convenient when attaching a light. Please contact Anton/Bauer for information about the lighting system.

- 2** Insert the battery and slide it in the direction of the arrow.

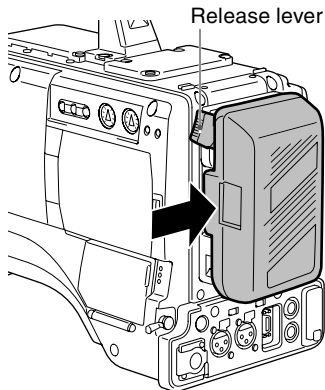

<Note>

●Removing the battery pack
Completely push down and hold the release lever on the battery holder. Then, slide the battery pack in the opposite direction to the arrow while holding the lever down.

- 3** Set the battery type.

- Select the battery type listed under BATTERY SELECT. Select the menu option BATTERY SELECT from the setting menu BATTERY SETUP screen.

■The following Anton/Bauer batteries can be used:

- PROPAC14
- TRIMPAC14
- HYTRON50
- HYTRON140
- DIONIC90
- DIONIC160

Using an NP-1 type battery pack

When replacing the battery holder, consult your distributor.

- 1** Remove the battery holder.

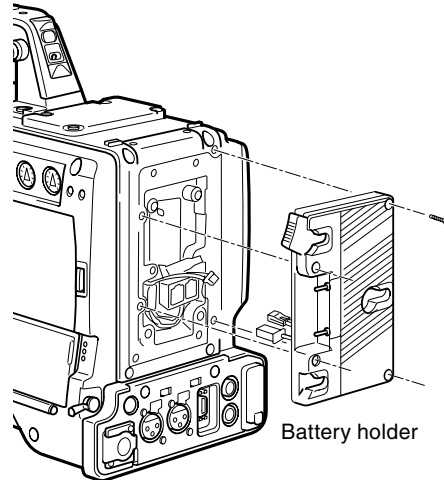

- 2** Mount the NP-1 type battery case on the camera-recorder.

- ① Tighten the mounting screws.
- ② Tighten the power contact screws.
- ③ Insert the upper part of the removed cover in the direction of the arrow.
- ④ Align the holes in the bottom part (metal part) of the cover with the holes in the case, and secure the cover with the screw.

<Note>

When mounting the battery holder, take care not to pinch the connection cord.

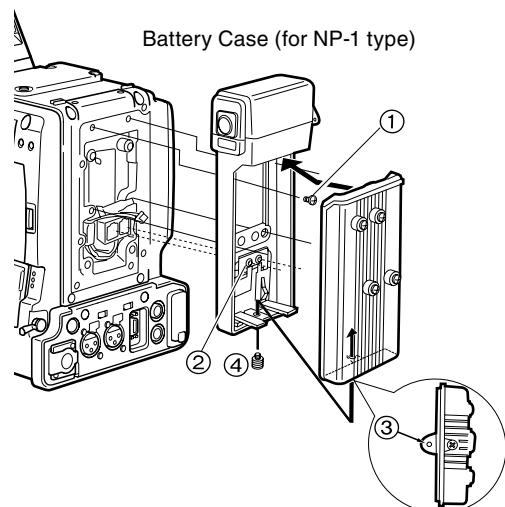

When using a V-mount type battery pack

Mount the V-mount adapter plate. Insert the plate and slide it as shown below.

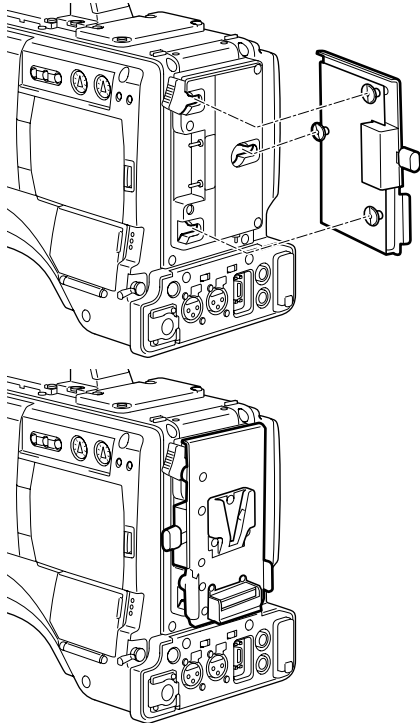

Setting the battery type

- Select the battery type listed under BATTERY SELECT. Select the menu option BATTERY SELECT from the setting menu BATTERY SETUP screen.
- When using a battery not listed under BATTERY SELECT:
If it is a NiCd battery, select “NiCd14(14V)” and set each item according to the battery characteristics.
If it is not a NiCd battery, select TYPE A or TYPE B and set each item according to the battery characteristics. Please refer to [BATTERY SETUP screen] (page 127) for more information.

<Note>

For information about the V-mount adapter plate, please contact the store where you purchased the camera-recorder.

Use of the external DC power supply

1 Connect the external DC power supply to the DC IN socket on the unit.

Attach the two ferrite cores (provided) to both ends of the DC cable in such a way that the ferrite cores fit within about 5 cm (2 inches) from the connectors, as shown below. Close each ferrite core until it clicks into place and locks.

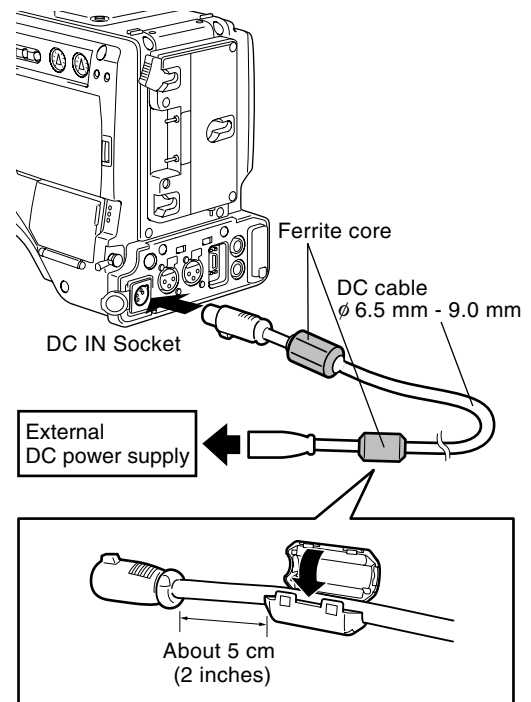

<Note>

Handle the ferrite cores with care as they are prone to shatter when subjected to an impact force, such as when dropped.

2 Turn “ON” the power switch of the external DC power supply. (If the power switch is available on the external DC power supply)

3 Turn the camera-recorder power switch ON.

- When the power is turned on, a rush current occurs. If the power supply is insufficient during this time, the camera may be damaged. Therefore, we recommend using an external DC power supply that provides at least twice the total power consumed by the camera and all the devices connected to the unit that power on when the camera powers on (example: viewfinder). We also recommend using the proper DC cable recommended for your external DC power supply.
- When using an external power supply other than the AC adapter, check the DC IN socket pin information to ensure correct polarity. If a +12 V power supply is accidentally connected to the GND terminal, this could cause a fire or personal injury.

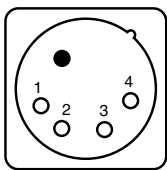

DC IN Socket

Pin No.	Signal
1	GND
2, 3	-
4	+12V

<Notes>

- When both the battery pack and the external DC power supply are connected, power is supplied from the external DC power supply. The battery can be removed or mounted while using an external DC power supply.
- When using an external DC power supply, make sure you turn on the external DC power supply before turning on the camera-recorder's power switch. If this sequence is reversed, the camera-recorder may malfunction due to slow rising of the external DC power supply voltage.
- To connect a battery to the DC IN connector, select BATTERY in the EXT DC IN SEL item, and select the battery type in the BATTERY SELECT item in the BATTERY SETUP screen. Note that with these settings, the "%" indication cannot be displayed, even for batteries capable of indicating remaining power.
- Before connecting an external DC power supply, make sure its output voltage is compatible with the rated voltage of the camera.

Mounting the Viewfinder and Adjusting its Position

This section shows how to mount and adjust the supplied viewfinder and the optional AG-VF11G viewfinder, which is equivalent to the supplied one. When using a viewfinder other than these two viewfinders, see the Operating Instructions provided with that viewfinder.

- Note that old attachment models are not supported.

Mounting the Viewfinder

- 1 Confirm that the **POWER** switch is turned off.
- 2 Connect the plug to the viewfinder connector.
<Note>
Make sure that the plug is firmly seated in the viewfinder connector.

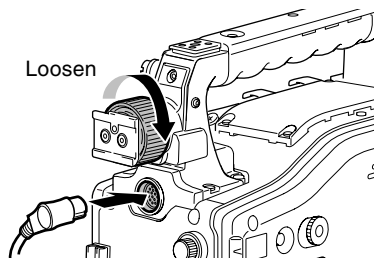

- 3 Loosen the viewfinder right-left positioning ring.
- 4 Turn the viewfinder securing screw counterclockwise (to cancel the safety mechanism) and slide the viewfinder in the direction of the arrow.

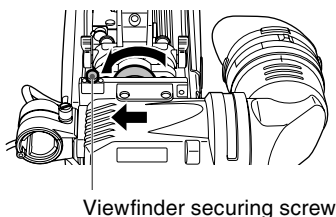

- 5 Turn the viewfinder securing screw clockwise (to prevent it from falling off).

- 6 Tighten the viewfinder right-left positioning rings.

<Note>

Be sure to firmly tighten the viewfinder securing screw on the viewfinder right-left positioning module. The viewfinder may fall off if the viewfinder securing screw is not properly tightened.

Adjusting Viewfinder Right-Left Position

- 1 Loosen the viewfinder right-left positioning ring.
- 2 Slide the viewfinder right and left to find a position that facilitates viewing.

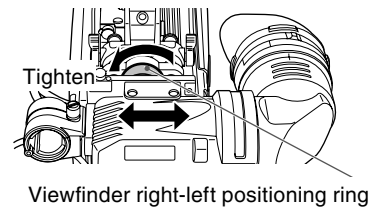

- 3 Tighten the right and left viewfinder positioning ring.

Diopter Adjustments

- 1** Turn on the **POWER** switch on the camera.
 - Look at the image in the viewfinder.

- 2** Turn the diopter adjusting ring until you get the sharpest possible image in the viewfinder.

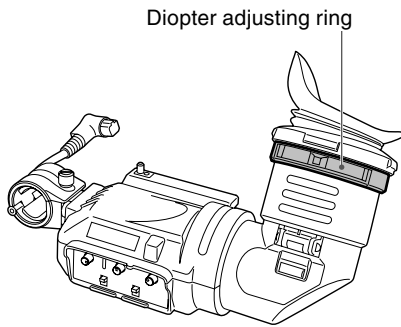

Screen Adjustments

Use the following controls to adjust viewfinder screen.

- Brightness: Turn the **BRIGHT** control.
- Contrast: Turn the **CONTRAST** control.
- Peaking: Turn the **PEAKING** control.

- 1** Turn on the **POWER** switch on the camera.

- 2** Set the **OUTPUT** switch of the camera to **BARS**.

- 3** Turn the viewfinder **BRIGHT** and **CONTRAST** controls to adjust viewfinder brightness and contrast.
 - Turn the **PEAKING** control to obtain a sharp image.
 - A sharper viewfinder image will facilitate focusing.

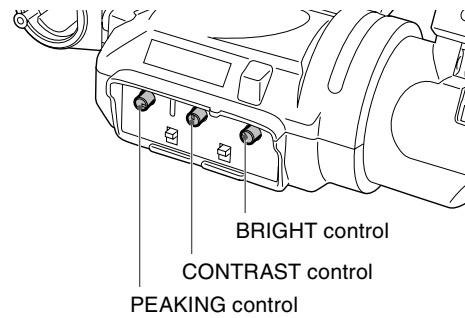

Removing the Viewfinder

- 1** Confirm that the POWER switch is turned off.
- 2** Loosen the viewfinder right-left positioning rings.
- 3** Turn the viewfinder securing screw counterclockwise, slide the viewfinder in the direction of the arrow and remove it.

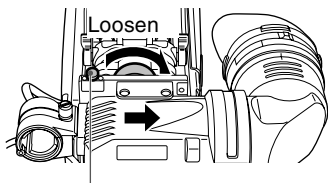

Viewfinder securing screw

- 4** Disconnect the viewfinder cable and microphone cable from the clamp and remove them.

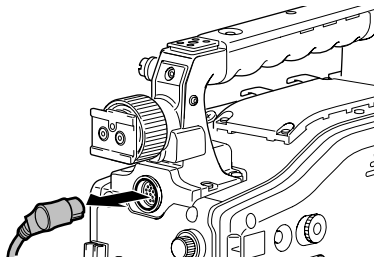

Mounting and Adjusting the Lens

Mounting the Lens

- 1 Raise the lens clamping lever and remove the mount cap.

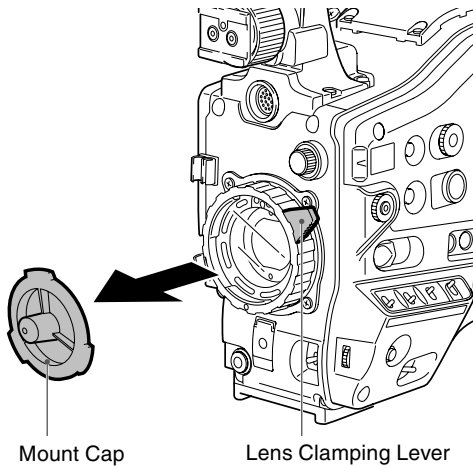

- 2 To mount the lens, align the indentation at the top center of the lens mount with the center mark of the lens.

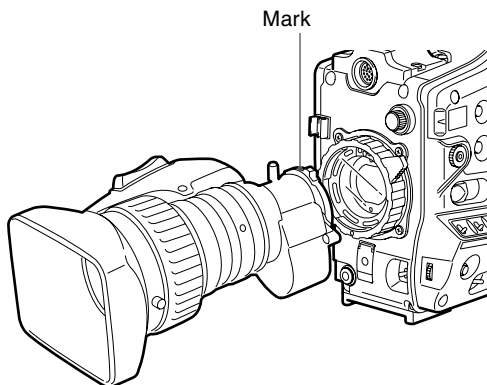

- 3 Lower the lens clamping lever to clamp the lens.

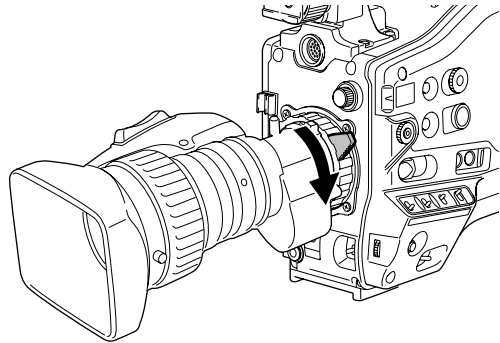

- 4 Secure the cable through the cable clamp, and plug it into the LENS connector.

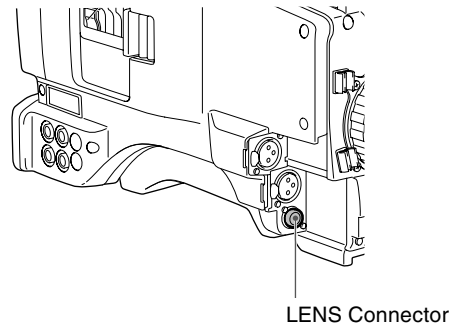

- 5 Adjust the lens flange back.

<Notes>

- Please refer to the lens instruction manual for guidance on lens handling.
- When the lens is removed, install the mount cap to protect the device.

Adjusting the Lens Flange Back

If images are not clearly focused at both telephoto and wide-angle positions during zoom operations, adjust the flange back (distance from the lens mounting surface to the image formation surface).

Once adjusted, the flange back does not need to be re-adjusted as long as the same lens is mounted on the camera.

<Note>

Please also refer to the lens instruction manual for directions on adjustment and locations of individual lens parts.

- 1 Mount the lens on the camera.**
 - Make sure you connect the lens cable.

- 2 Set the lens iris to manual, and fully open the iris.**

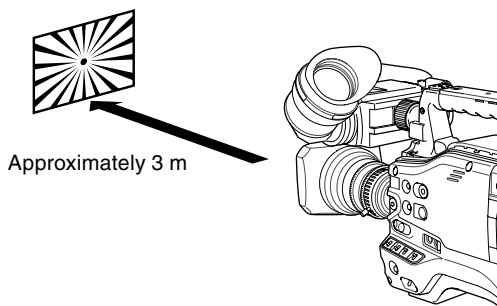

- 3 Place the flange back adjustment chart about 3 m from the lens and adjust the lighting on the chart to obtain an appropriate video output level.**
 - If the video level is too high, use the filters or the shutter.

- 4 Loosen the F.f (Flange focus) ring clamping screw.**

<Note>
F.b (Flange back) may be indicated on some lenses.

- 5 Set the zoom ring to the telephoto position, either manually or by electric drive.**

- 6 Aim the lens at the flange back adjustment chart and turn the distance ring to bring the chart into focus.**

- 7 Set the zoom ring to the wide-angle position and turn the F.f ring to bring the chart into focus.**

- While focusing, take care not to move the distance ring.

- 8 Repeat Steps 5 to 7 until the lens is in focus at both the telephoto and wide-angle positions.**

- 9 Firmly tighten the F.f ring clamping screw.**

White Shading Compensation

The camera can use DEFAULT (fixed value) and three user adjustable functions (USER1, USER2, USER3) to store white shading compensation data.

Select SHADING SELECT in the setting menu LENS SETUP screen to set compensation data. Selecting OFF turns off shading compensation.

Selecting White Shading Compensation Data

- 1 Open the setting menu LENS SETUP screen.**

For details on menu operation, refer to [Using the menus] (page 116).

- 2 Use the JOG dial button to select SHADING SELECT, then press the JOG dial button.**

LENS SETUP	
SHADING SELECT	▶ DEFAULT
SHADING(USER)	----
CAC PROPERTY	----
CAC CARD READ	----
CAC FILE DELETE	----
CAC FILE INIT	----
IRIS ADJUST	OFF
PUSH MENU TO RETURN	

3 Use the JOG dial button to select **DEFAULT, USER1, USER2, USER3** or **OFF** and press the JOG dial button.

- To adjust the white shading, select USER1, USER2 or USER3.
- The USER1, USER2 or USER3 settings do not contain any compensation data by default.
- Store compensation data that suits KJ16ex7.7B IRSD PS12 and KJ16ex7.7B KRSD PS12 in DEFAULT. For lenses other than those above, perform the “White Shading Adjustment” described below.

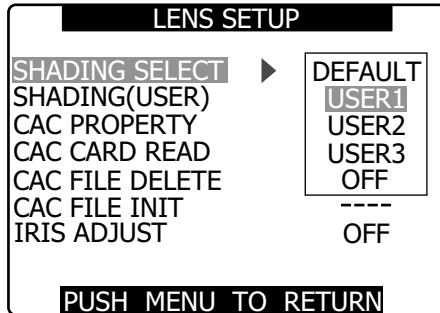

White Shading Adjustment

<Note>

Coloring may occur in the vertical direction near the open setting of the lens iris even when the white shading has been adjusted. This is an optical characteristic and not indicative of a failure.

1 Place the camera in the adjustment mode.

- (1) Mount a lens on the camera.
 - Do not forget to connect the lens cable.
- (2) Turn off the electronic shutter and set the gain to L (0 dB).
- (3) If the lens comes with an extender, disengage it.
- (4) Open the setting menu LENS SETUP screen and select USER1, USER2 or USER3 under SHADING SELECT.
- (5) Use the JOG dial button to select SHADING (USER), select YES and press the JOG dial button.
 - The message “CHECK LUMINANCE LEVEL ZEBRA ON VF” appears.

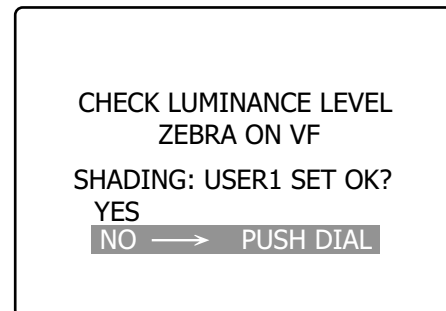
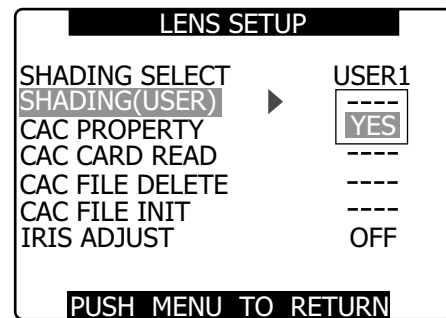

2 Set the image.

- (1) Shoot a solid white sheet of paper.
- (2) Set the lens iris to manual and adjust the iris so that a zebra pattern fills the entire viewfinder screen.
 - When the piece of paper is unevenly lit, the zebra pattern will not cover the entire screen. Adjust as required.
 - Make sure that the white paper is not exposed to multiple light sources (example, fluorescent lighting or halogen lamps) of different color temperatures.

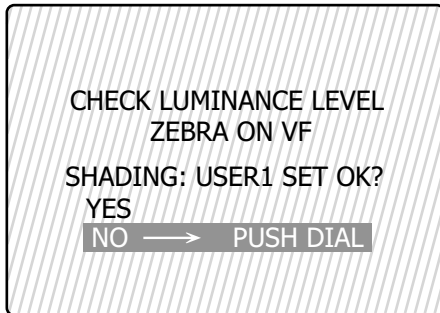

<Note>

- Adjust the white shading in sunlight, under halogen lamp light or other light source that does not flicker. Fluorescent light and mercury lamps tend to flicker and should not be used for this adjustment.
- Adjust the light source if the lens iris is out of the range between F4 and F11.
- Make sure the electronic shutter is set to off.

6 If the lens is provided with an extender, turn on the extender function and perform steps 2 to 5 again.

- The white shading adjustment need not be readjusted when the extender is later turned off.

3 Adjust white and black balance.

- (1) Set the WHITE BAL switch to A or B and use the AUTO W/B BAL switch to make an automatic white balance adjustment.
- (2) Use the AUTO W/B BAL switch to make an automatic black balance adjustment.
- (3) Again, use the AUTO W/B BAL switch to make an automatic white balance adjustment.

4 Repeat the operation in step 2-(2).

5 Adjust white shading.

- (1) Use the JOG dial button to select YES and press the JOG dial button.
- (2) The message "SHADING ACTIVE" appears on the screen during adjustment.
- (3) When the adjustment ends after a few seconds, the message "SHADING OK" appears.
 - When an error message such as "SHADING NG LEVEL OVER" or "SHADING NG LOW LIGHT" appears, adjust the iris.
 - The adjusted value is automatically stored in memory (USER1, USER2, USER3).

Setting Chromatic Aberration Compensation (CAC)

The CAC function of the camera corrects the registration error caused by the slight chromatic aberration that the lens cannot compensate for. This minimizes color bleeding into the surrounding image areas.

Lenses compatible with the CAC function whose CAC data is registered in the camera will automatically start CAC operation.

CAC data for the following four lenses have been registered in the camera as default values.

Camera indication	Model numbers of compatible lenses
KJ16EX7.7B IRSD PS12	KJ16ex7.7B IRSD PS12
	KJ16ex7.7B KRSD PS12
KJ21EX7.6B IRSD PS12	KJ21ex7.6B IRSD PS12
KJ10EX4.5B IRSD PS12	KJ10ex4.5B IRSD PS12
XA17X7.6BERM-M58B	XA17x7.6BERM-M58B
	XA17x7.6BRM-M58B

<Note>

- One of the lens model number appearing in the menu represents the lens group.
- The CAC function in this camera operates in horizontal direction only.
- The CAC function does not operate at +18 dB.
- The CAC function may not operate normally in macro shooting.
- After the release of this camera, visit our Web site at the address given below for details on new lenses compatible with this function and any changes in this function.
<http://pro-av.panasonic.net/>

Checking CAC Operating Status

Press the DISP/MODE CHK button when no menu is open.

- CAC is running if “CAC” appears in the upper right corner of the screen.

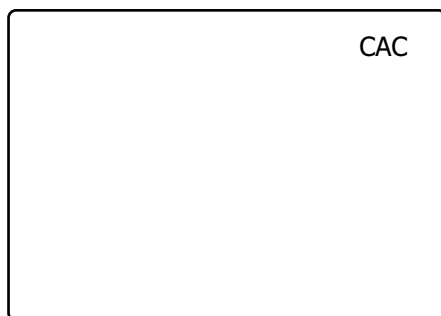

Checking CAC data number and CAC data during operation

- 1 Open the setting menu LENS SETUP screen.**
For details on menu operation, refer to [Using the menus] (page 116).
- 2 Turn the JOG dial button to select CAC PROPERTY and select YES to open the CAC PROPERTY screen.**
 - The CAC property list appears.

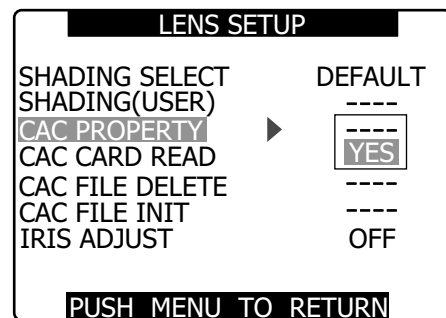

■ CAC Property

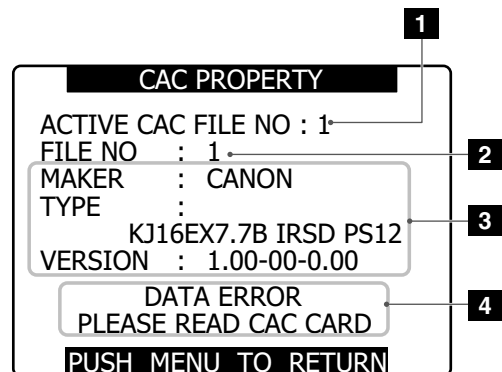

- 1 Current CAC data number**
- 2 Data number of CAC you wish to check**
Turn the JOG dial to select.
- 3 CAC data specified by 2**
- 4 Error messages**

The file cannot be used if an error message appears. Initialize the CAC data or reload the CAC file from an SD card.

For details, see [Initializing CAC File] (page 97) or [Loading CAC File from an SD Card] (page 96).

Loading CAC File From an SD Card

- 1 Open the setting menu LENS SETUP screen.
For details on menu operation, refer to [Using the menus] (page 116).
- 2 Use the JOG dial button to select CAC CARD READ. Then select YES to open the CAC CARD READ screen.

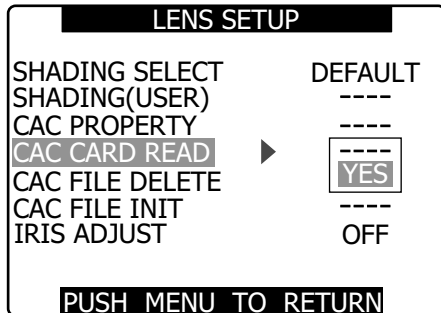

- 3 Use the JOG dial button to select the CAC file to load. Then select YES and press the JOG dial button.

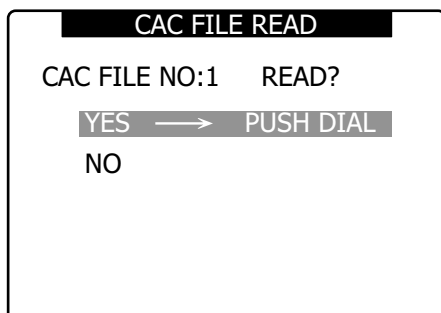
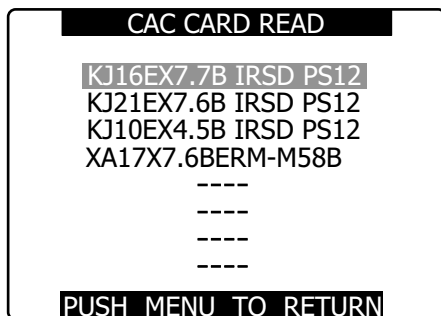

Deleting CAC File

- 1 Open the setting menu LENS SETUP screen.
For details on menu operation, refer to [Using the menus] (page 116).
- 2 Use the JOG dial button to select CAC FILE DELETE, select YES and press the JOG dial.

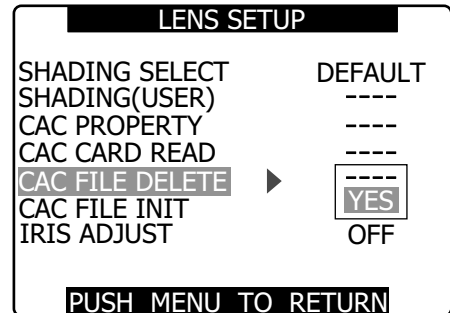

- 3 Use the JOG dial to select the CAC file to be deleted. Then select YES and press the JOG dial button.
“----” is indicated when deletion ends.

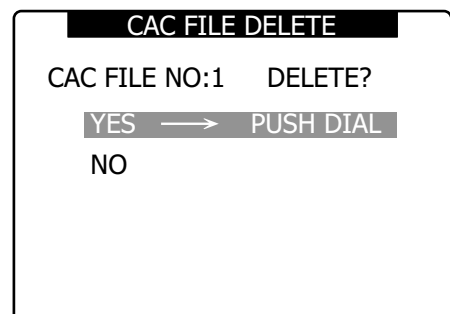
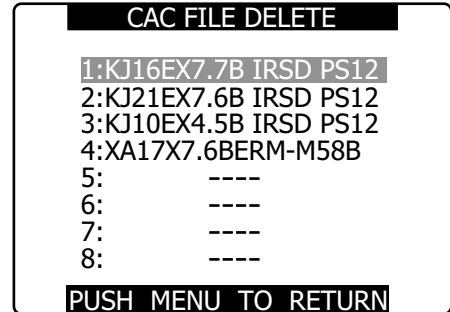

<Note>

- The camera can load up to 8 files.
When an attempt is made to load a new file while 8 files have already been loaded, “READ NG CAC FILE FULL” appears. To load new file, delete an existing file before loading the new file. For details, see [Deleting CAC File] (page 96).
- “READ NG FORMAT ERROR” indicates the file cannot be used and will not be loaded. Make sure the file is in a format the camera supports and that the file on the SD card is not corrupted.

Initializing CAC File (Returning Data to Their Factory Defaults)

- 1 **Open the setting menu LENS SETUP screen.**
For details on menu operation, refer to [Using the menus] (page 116).

- 2 **Use the JOG dial button to select CAC FILE INIT. Then select YES to display the confirmation screen.**

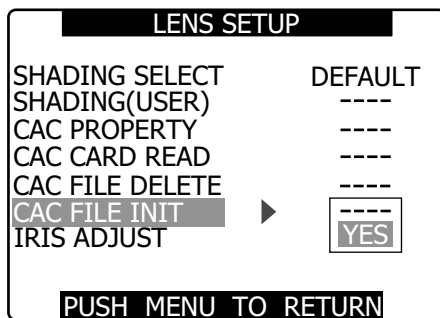

- 3 **Select YES in the confirmation screen and press the JOG dial button.**
 - “CAC FILE INIT PROCESSING COMPLETED” is displayed to indicate that initialization is completed.
 - The LENS SET UP screen appears after completion.

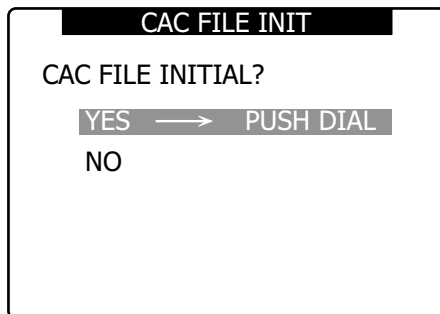

<Note>

This operation deletes all files and returns the four CAC files to their factory defaults.

Preparing for Audio Input

Take the following steps to prepare the camera for connecting audio input devices.

When Using the Front Microphone

The AJ-MC200G microphone kit (optional) includes a microphone that can be mounted on the camera.

- 1 Open the microphone holder.

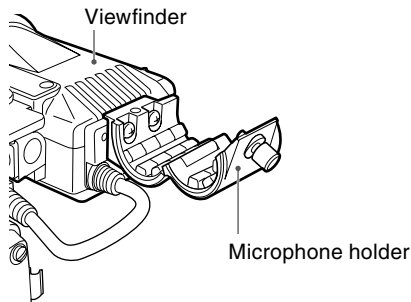

- 2 Mount the microphone and tighten the clamping screw.

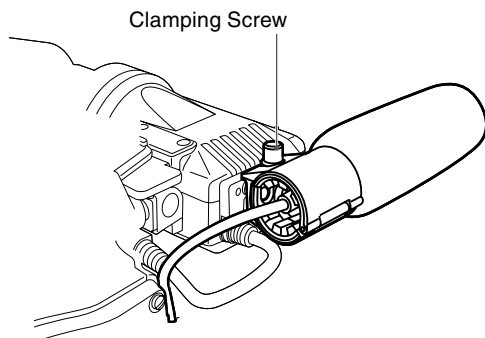

- 3 Connect the microphone cable to the MIC IN jack on the camera.

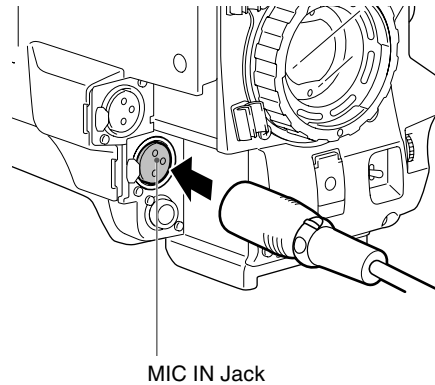

- 4 Set the AUDIO IN switch to [FRONT] depending on the audio channel to be recorded.

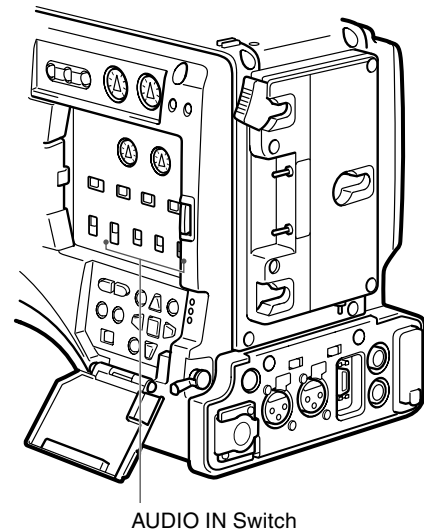

<Note>

When the microphone connecting cable is connected to the FRONT2 jack and the AUDIO IN switch CH1 is set to FRONT2 and switch CH2 is set to FRONT, sound from the microphone sound is input to both channels.

When Using Audio Devices

- 1** Connect the audio device to the AUDIO IN jack with the XLR cable.
- 2** Set the AUDIO IN switch to [REAR] for the channel to which the XLR cable is connected.
- 3** Set the LINE/MIC/+48V selector switch on the rear panel to [LINE].

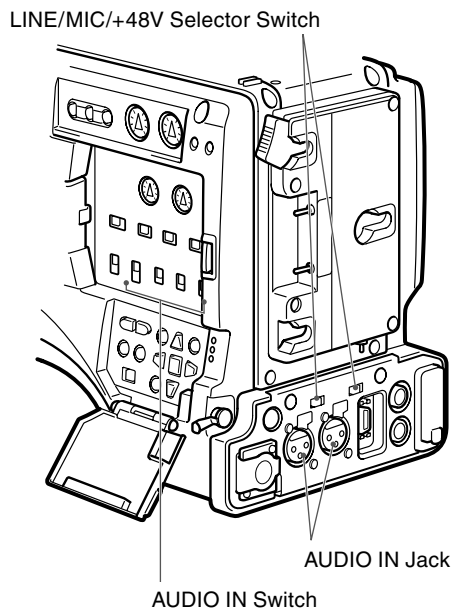

Attaching Accessories

Mounting the Camera on a Tripod

When mounting the camera on a tripod, use the tripod adapter supplied with the camera.

1 Mount the tripod adapter on the tripod.

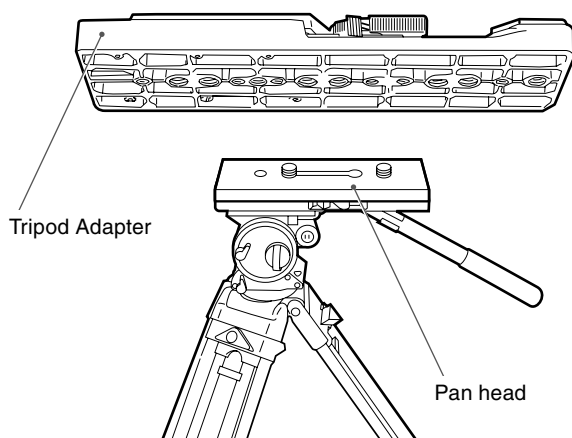

<Note>

Select an appropriate hole in the adapter, taking into account the center of gravity of the camera and tripod adapter combined. Also, make sure that the diameter of the selected hole matches the diameter of the pan head screw.

2 Mount the camera on the tripod adapter.

- Slide the camera forward along the grooves until you hear a “click”.

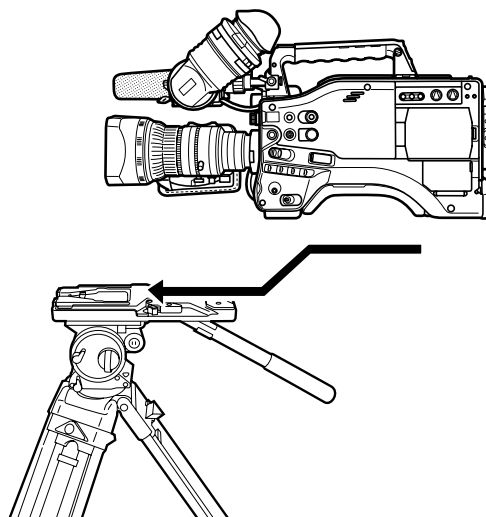

Removing the Camera from the Tripod Adapter

While holding the red lever down, move the black lever in the direction of the arrow, and slide the camera backward to remove it.

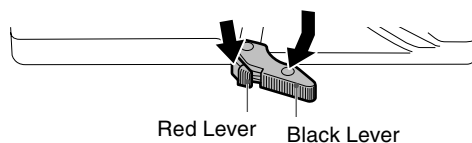

<Note>

If the tripod adapter pin does not return to its original position after the camera has been removed, hold the red lever down and move the black lever in the direction of the arrow again, in order to return the pin to its original position. Please note that the camera cannot be mounted if the pin remains in the center.

Attaching the Shoulder Strap

To detach the shoulder strap, first open the hooks, then detach the strap.

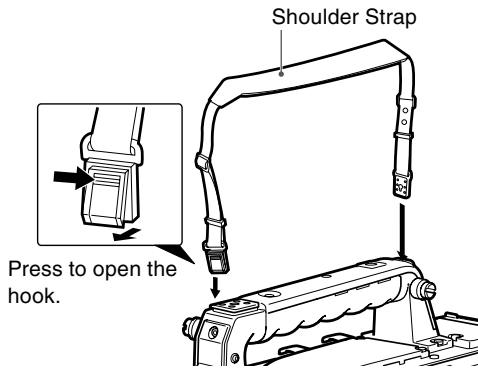

<Note>
Make sure that the shoulder strap is securely attached.

Attaching the Rain Cover

When using the SHAN-RC700 Rain Cover

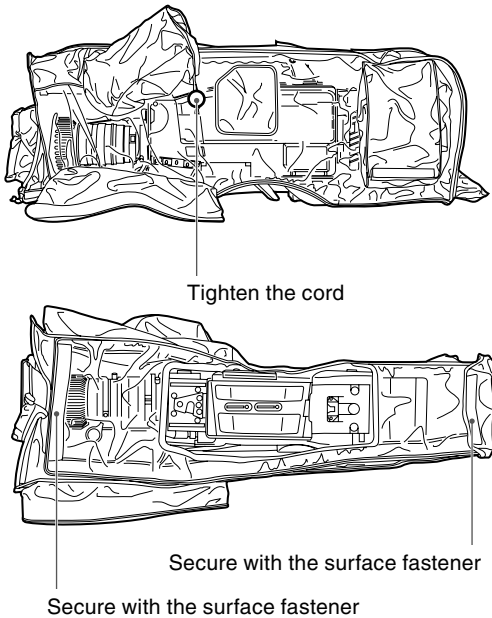

Attaching the FRONT AUDIO LEVEL Control Knob

If you use the FRONT AUDIO LEVEL control frequently, attach the accessory knob so that it can be easily operated.

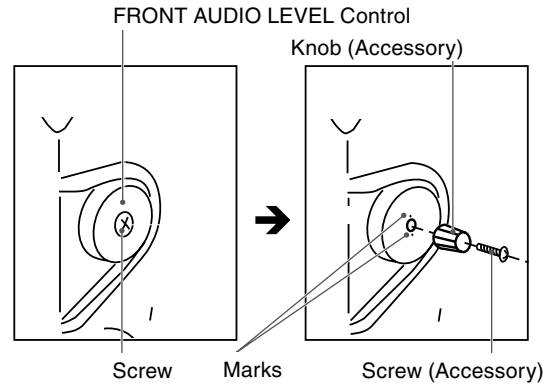

Remove the screw in the center of the FRONT AUDIO LEVEL control, and attach the accessory knob using the screw (included). When attaching the knob, be sure to align the marks on the control with the marks on the knob.

Connecting the AJ-RC10G Extension Controller

- Some functions can be remote-controlled when the AJ-RC10G extension control unit (optional) is connected to the camera.
- When the AJ-RC10G is connected, the camera automatically enters remote control mode after the power switches of both the camera and the AJ-RC10G are turned ON.

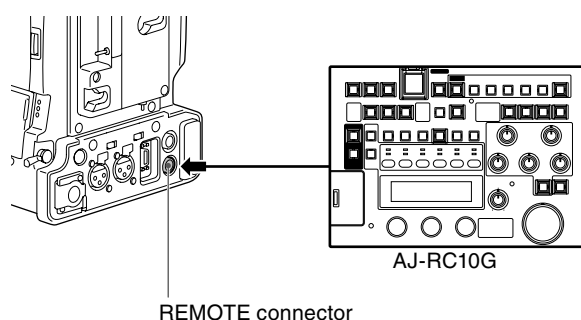

<Note>

- Be sure to turn OFF both the camera and the AJ-RC10G power switches before connecting or disconnecting the controller cable.
- If RC DATA SAVE (AJ-RC10G) is set to OFF, the camera-related setting values, which have been adjusted or set using the AJ-RC10G, will be cancelled when the camera power switch is turned OFF. Also, the setting values cannot be written to an SD memory card. However, the menu settings performed using the AJ-RC10G can be written to an SD memory card. Next time the AJ-RC10G is connected, the setting values will return to the AJ-RC10G settings.
- If RC DATA SAVE (AJ-RC10G) is set to ON, the values adjusted or set using the AJ-RC10G are retained, even after the camera power switch is turned OFF.
- The USER switch on the camera does not function when the AJ-RC10G is connected.
- Refer to the Operating Instructions of the AJ-RC10G included in the supplied CD-ROM.

A clip is a data group that includes the images and voices created from one shooting session, together with additional information such as text memos and meta data.

The following manipulations can be performed using the cursor and SET buttons, while checking the images displayed on the LCD monitor:

- Play back, delete and repair clips
- Add or delete a shot mark and text memo on the clip thumbnail.
- Format P2 cards and SD memory cards.
- Upload the clip meta data from an SD memory card.

Thumbnail Operations

Thumbnail Overview

Thumbnail screens are configured as follows:

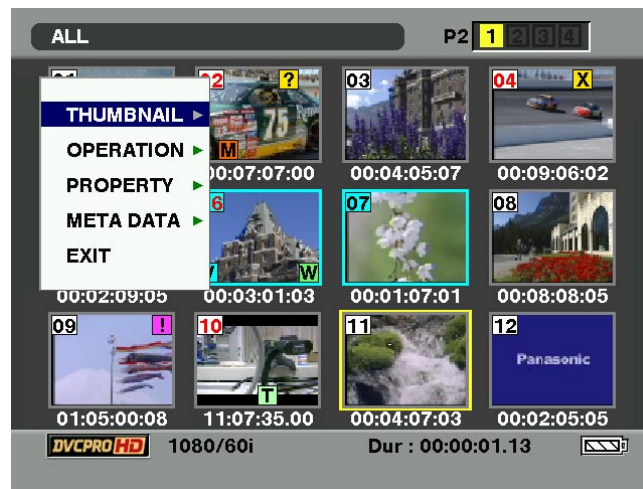

THUMBNAIL

- ALL CLIP
- SAME FORMAT CLIPS
- SELECTED CLIPS
- MARKED CLIPS
- TEXT MEMO CLIPS
- SLOT CLIPS
- SETUP
- EXIT

OPERATION

- DELETE
- FORMAT
- REPAIR CLIP
- REPAIR CLIP (LOOP)
- EXIT

PROPERTY

- CLIP PROPERTY
- CARD STATUS
- DEVICES
- PROPERTY SETUP
- SYSTEM INFO
- EXIT

META DATA

- LOAD
- RECORD
- USER CLIP NAME
- INITIALIZE
- PROPERTY
- EXIT

- Thumbnail screens are not output from the SDI OUT/COMPONENT OUT connectors.

Thumbnail Screen

Press the MODE button to engage the MCR mode and open the thumbnail screen on the LCD monitor. When switching is done from the regular screen display to the thumbnail screen display, all the clips will be displayed on the thumbnail screen.

Pressing the thumbnail menu button in the thumbnail screen moves the pointer to the setting menu providing access to allow thumbnail menu functions.

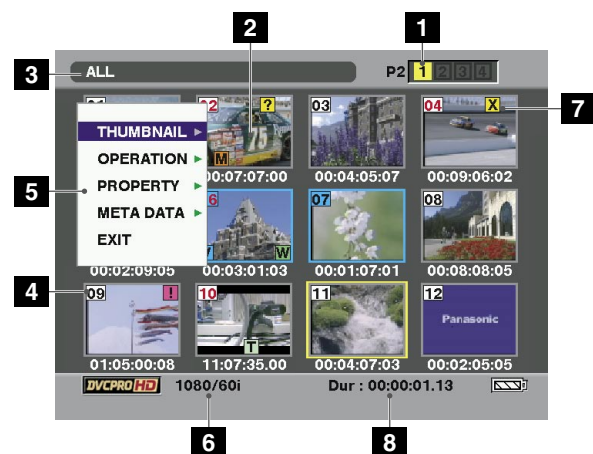

1 Slot number

- The number of the slot with the P2 card containing the selected clip is indicated here. (The number appears in yellow.)
- If a clip extends over the P2 cards in two or more slots, numbers will appear in yellow.
- When one of the following warnings applies to an inserted P2 card, the frame around the slot number turns pink.
[RUN DOWN CARD]
The maximum number of overwrites on the P2 card has been exceeded.
[DIR ENTRY NG CARD]
The directory structure on the P2 card is not supported.

2 Thumbnails

This is where the initial images of the clips are displayed.

3 Thumbnail display status

The types of clips displayed as thumbnails appear in this area.

4 Clip numbers

- The clips are displayed in the order in which they were shot.
- Clips in the wrong recording format or clips which cannot be played back for other reasons are shown in red.
- To play clips indicated by the red numbers, set the format for the REC FORMAT/MCR FORMAT option on the RECORDING SETUP setting menu to the format **6** below.
- Clips on the playlist which have been edited and copied using the AJ-SPD850 memory card recorder or other such unit and which have more than one format (DVCPRO/DV or DVCPRO50) are shown in red, and these clips cannot be played back even when the REC FORMAT item has been set.

5 Menu display

- This is where the menu items are displayed.

- When EXIT is selected and the SET button is pressed, the menu display is cleared, and the original screen is restored.

6 Recording mode/format display

This is where the recording mode and format of the recorded images are displayed.

7 Indicators

M (Shot mark):

This indicates that a clip has a shot mark.

W (Wide):

This indicates that a clip has been recorded in the 16:9 aspect ratio (wide screen). (480i/576i recording)

! (Incomplete clip):

This indicator appears when the recording of a clip extends over two P2 cards and one of the cards is not found in the slot.

X (Defective clip):

- This indicator appears for a clip whose recording was defective because the power was cut off during the recording process, for instance.
- Clips indicated by the yellow defective clip indicator can be repaired.
- Clips indicated by the red defective clip indicator cannot be repaired so delete them. If a clip cannot be deleted, first back up its data, and then format the P2 card. Clips in the wrong format are indicated by (?) instead.

V (Voice memo):

This indicates that a clip has a voice memo. (You cannot perform recording/playback with this camera.)

T (Text memo):

This indicates that a clip has a text memo.

E (Edit copy):

This indicates that this is an edit copy clip. (You cannot perform editing with this camera.)

P (Proxy):

This indicates that a proxy has been added and recorded. (You cannot perform recording with this camera.)

<Note>

For detailed explanations on **V**, **T**, **E**, and **P**, refer to the Operating Instructions supplied with the devices used to record or edit the voice memo, text memo, edit copy clip, and proxy respectively.

8 Duration display

This displays the duration of the selected clip.

Selecting Thumbnails

Multiple thumbnails can be randomly selected in the thumbnail screen.

1 Use the cursor buttons to move the pointer (yellow frame) to the desired clip and press the SET button.

- The frame around the selected thumbnail changes to a blue frame. Press the SET button again to deselect the clip.

2 Additional clips can be selected by repeating Step 1.

It is possible to display only the selected thumbnails in the thumbnail screen for playback. Please refer to [Switching the Thumbnail Display] (page 105) for more information.

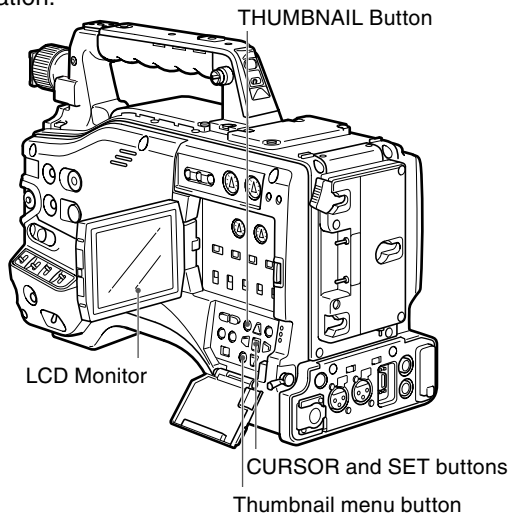

Switching the Thumbnail Display

The display can be switched so that only those clips matching the specified conditions are displayed in the thumbnail screen.

- 1 Press the MODE button to enter the MCR mode.**
 - The thumbnail screen appears on the LCD monitor.

- 2 Press the thumbnail menu button to open the menu.**

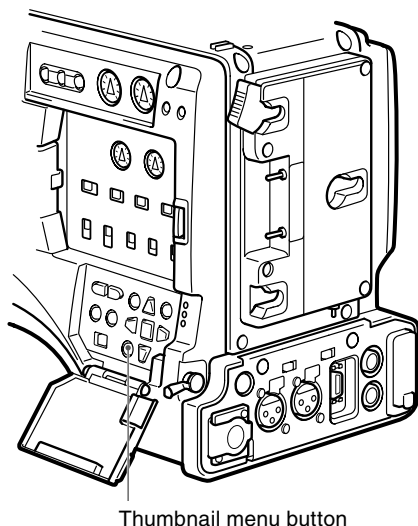

- 3 Move the pointer to THUMBNAIL and select with the SET button.**

- The setting sub-menu appears.
- Select the desired item to specify the type of thumbnail display.



- **ALL CLIP:**
Display all clips.
- **SAME FORMAT CLIPS:**
The clips in the same recording (or MCR) format are displayed.
- **SELECTED CLIPS:**
Display randomly selected clips.
- **MARKED CLIPS:**
Display clips with shot marks attached.
- **TEXT MEMO CLIPS:**
Clips with text memos are displayed. Thumbnails at text memo positions, time codes (TC), total number of memos and the current order of the clips are displayed.
- **SLOT CLIPS:**
Display clips recorded in the P2 card inserted in the specified slot.
- **SETUP:**
Various setup operations are performed.
- **EXIT:**
The previous screen reappears.

■ To delete a text memo

- 1 Select THUMBNAIL → TEXT MEMO CLIPS, move the cursor to the text memo to be deleted and press the SET button.**
- 2 Move the cursor to the text memo thumbnail to be deleted.**
- 3 Press the MENU button to open the setting menu and choose OPERATION → DELETE.**
 - The text memo is deleted.
 - Pressing the thumbnail button and selecting EXIT returns the pointer to the top of the thumbnail display.

Setting the Thumbnail Display Mode

The thumbnail display mode can be customized to suit your preferences.

- 1 Press the **MODE** button to enter the **MCR mode**.
 - The thumbnail screen appears on the LCD monitor.
- 2 Press the thumbnail menu button to open the menu.
- 3 Select **THUMBNAIL** → **SETUP**.

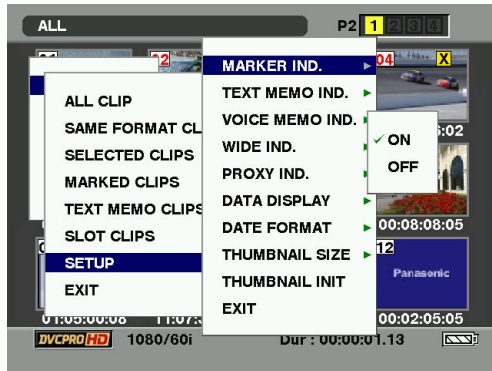

- **MARKER IND.:**
Shows or hides (ON/OFF) the shot mark indicator. The factory setting is ON (indication).
- **TEXT MEMO IND.:**
Shows or hides (ON/OFF) the text memo indicator. The factory setting is ON (indication).
- **VOICE MEMO IND.:**
Shows or hides (ON/OFF) the voice memo indicator. The factory setting is ON (indication).
- **WIDE IND.:**
Shows or hides (ON/OFF) the wide indicator. The factory setting is ON (indication).
- **PROXY IND.:**
Shows or hides (ON/OFF) the proxy indicator. The factory setting is ON (indication).
- **DATA DISPLAY:**
The time display field of the clip offers a choice of Time Code (TC), User Bits (UB), Shooting Time (TIME) or Shooting Date (DATE)/Shooting Time and Date (DATE TIME). The factory setting is Time Code.

- **DATE FORMAT:**

You can specify the display order for the shooting date as either Year/Month/Day (YMD), Month/Day/Year (MDY) or Day/Month/Year (DMY). The factory setting is Year/Month/Day.

This setting is reflected in the recording date shown in the clip property and the shooting date shown when DATE is selected under the item DATA DISPLAY.

- **THUMBNAIL SIZE:**

For the size of thumbnails displayed on one screen, either LARGE (3 × 2 thumbnails displayed) or NORMAL (4 × 3 thumbnails displayed) can be selected. The factory default value is NORMAL.

- **THUMBNAIL INIT:**

Return the above thumbnail display settings to default.

Move the cursor to this option, and press the SET button. Select "YES" when the confirmation screen is displayed.

- **EXIT:**

Returns to the previous menu.

Clip Operations

Playing Back Clips

- 1 Press the MODE button to enter the MCR mode.**
 - The thumbnail screen appears on the LCD monitor.
- 2 Use the cursor buttons to move the pointer over the desired clip.**
- 3 Press the PLAY button, and the clip under the pointer will be played back on the LCD monitor.**
 - After playback of the clip under the pointer, subsequent clips are played back in order, according to when they were shot. The thumbnail screen returns after the last clip has been played back.
 - <Notes>**
 - When playing back clips, it is not necessary to “select” the clips (blue frames around the thumbnails).
 - Clips with clip numbers displayed in red cannot be played.
- 4 During playback, pressing the REW button starts 4x speed reverse playback, and the FF button starts 4x speed fast playback.**
 - Press the PLAY button to return to normal playback.
- 5 During clip playback, pressing the STILL button will temporarily stop (pause) the process.**
 - During a pause, pressing the REW button moves the pause position to the beginning of the clip.
 - Pressing the REW button again moves the pause position to the beginning of the previous clip.
 - During a pause, pressing the FF button moves the pause position to the beginning of the next clip. (Holding down the FF button displays the last image in the last clip. “EOS” appears at this time.)

- 6 Pressing the STOP button during clip playback stops the playback and returns the display to the thumbnail screen.**
 - <Note>**
When playback is stopped, the position of the pointer remains on the clip that was being played back, regardless of where the playback started.

Shot Mark

A shot mark can be added to a clip thumbnail to distinguish this clip from the others.

- 1 Press the MODE button to enter the MCR mode.**
 - The thumbnail screen appears on the LCD monitor.
- 2 Use the cursor buttons to move the pointer over the clip to which you want to attach a shot mark.**
- 3 Press the USER button to which the shot mark function has been assigned.**
 - Use the setting menu SW MODE screen to assign the SHOT MARK function to a USER button.

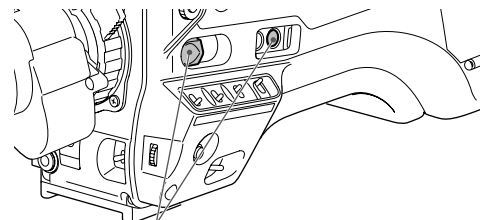

USER MAIN, USER1 and USER2 buttons

- 4 A shot mark will be attached to the clip thumbnail under the pointer.**
 - To delete a shot mark, reposition the pointer over the clip and press the Shot Mark button.

<Note>

When adding a shot mark to (or deleting the shot mark from) a clip recorded across multiple P2 cards, do this with all these P2 cards inserted into P2 card slots.

Deleting Clips

- 1 Press the **MODE** button to enter the **MCR** mode.
 - The thumbnail screen appears on the LCD monitor.
- 2 Use the cursor buttons to move the pointer over the clip you want to delete, and press the **SET** button.
 - Press the **SET** button to select the clip.
- 3 Press the thumbnail menu button to select **OPERATION** → **DELETE** from the menu bar.

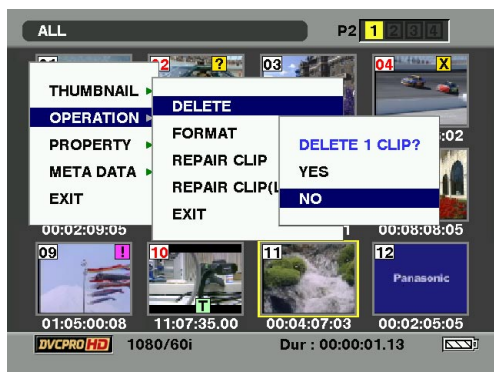

- 4 A screen to confirm the delete operation appears. Use the cursor buttons and the **SET** button to select **YES**.
 - The clip is deleted.
 - All selected clips (in blue-green frames) are deleted by this operation.

<Note>

After selecting multiple clips and during deletion with “CANCEL” indication displayed, pressing the **SET** button stops the deletion operation in the middle.

Restoring Clips

Restores clips that are defective as a result of sudden poweringdown during recording, or removal of the P2 card being accessed.

<Note>

- Only those clips with yellow corrupt clip markers can be restored. Delete the clips with red corrupt clip markers. If the clip cannot be deleted, format the P2 card.
- During restoration of the clips, however, the defective-clip indicator may change from yellow to red, resulting in inability to restore the clips.

- 1 Press the **MODE** button to enter the **MCR** mode.
 - The thumbnail screen appears on the LCD monitor.
- 2 Use the cursor buttons to move the pointer over the clip you want to restore (defective clips are indicated by corrupt clip marks), and press the **SET** button.
 - Press the **SET** button to select the clip.
- 3 Press the thumbnail menu button to select **OPERATION** → **REPAIR CLIP** from the menu bar.

<Note>
To restore a bad clip generated during loop recording, select **REPAIR CLIP (LOOP)**. Clip repair may take some time.
- 4 The confirmation window appears. Use the cursor buttons and the **SET** button to select **YES**.

Setting of Clip Meta Data

Information such as the name of person who shot the video, the name of the reporter, the shooting location, or a text memo can be read from the SD memory card, and can be recorded as Clip Meta Data.

Reading Clip Meta Data (metadata upload)

- 1** Insert the SD memory card that contains the Clip Meta Data (metadata upload file).
- 2** Press the MODE button to enter the MCR mode.
 - The thumbnail screen appears on the LCD monitor.
- 3** Press the thumbnail menu button to open the menu.
- 4** Select META DATA → LOAD from the menu bar.

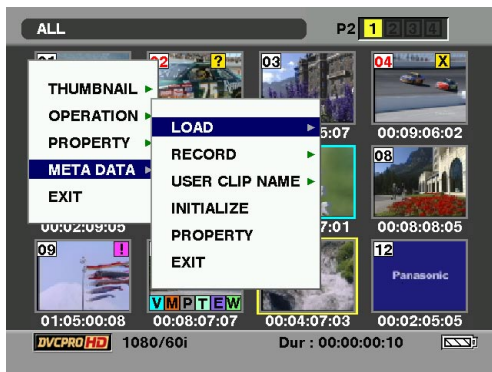

- 5** Names of metadata upload files stored on the SD memory card are displayed.
 - Select the desired files using the cursor buttons, and choose YES. Upload starts.
 - Uploaded metadata is retained even if the power is turned off.
 For confirmation of uploaded data, see [Confirmation of Metadata Upload] (page 115).

Clip metadata content

- Clip Meta Data includes the following items:
 - Underlined items can be set by reading the metadata upload file on the SD memory card.
- Other items are set automatically during shooting. Using the latest update version of P2 viewer, metadata upload files can be written to SD memory cards using a PC.
- Download the latest update version of P2 viewer from the following URL and install it to your PC: <http://pro-av.panasonic.net/>
See [Memory Card Usage] (page 83).

<Note>

The file which was edited by except P2 viewer is displayed as "UNKNOWN DATA", and may not be read.

• GLOBAL CLIP ID:

Displays the global clip ID, which indicates the shooting status of the clip.

• USER CLIP NAME:

Displays the clip name specified by the user.*

* If the metadata upload file does not contain any data, the global clip ID serves as the USER CLIP NAME. The USER CLIP NAME recording method is selectable. For more information, see [Selecting the USER CLIP NAME recording method] (page 110).

• VIDEO:

Displays [FRAME RATE] (frame rate of the clip), [PULL DOWN], and [ASPECT RATIO].

• AUDIO:

[SAMPLING RATE] (sampling frequency of recorded sound) and [BITS PER SAMPLE] (digitized bit[s] of recorded sound). Corresponds to CH1- CH4.

• ACCESS:

Displays [CREATOR] (person who recorded the clip), [CREATION DATE] (date when the clip was recorded), [LAST UPDATE DATE] (date of the latest update of the clip), and [LAST UPDATE PERSON] (person who made the latest update of the clip).

• DEVICE:

Displays [MANUFACTURER] (name of the device manufacturer), [SERIAL NO.] (serial number of the device) and [MODEL NAME] (model name of the device).

• SHOOT:

Displays [SHOOTER] (name of the person who shot the video), [START DATE] (start date of shooting), [END DATE] (end date of shooting), and [LOCATION/ALTITUDE/LONGITUDE/LATITUDE/SOURCE/PLACE NAME] (altitude, longitude, latitude, and source of the information and name of the location).

• SCENARIO*:

Displays [PROGRAM NAME], [SCENE NO.], and [TAKE NO.].

* Be sure to enter PROGRAM NAME when entering SCENARIO. It is not possible to record only the SCENE NO or TAKE NO.

- **NEWS:**

Displays [REPORTER] (name of the reporter), [PURPOSE] (purpose of shooting), and [OBJECT] (object of shooting).

- **MEMO*:**

Displays the NO. (memo number), OFFSET (frame position from the beginning of the clip), PERSON (name of the person who recorded the text memo), and TEXT (memo content).

* Be sure to enter TEXT when entering MEMO. It is not possible to record only PERSON.

<Note>

“*” appears when text cannot be correctly displayed, for example, when Japanese or Chinese metadata is displayed in English or when the metadata contains characters that cannot be rendered in English.

To set whether or not the uploaded metadata is recorded

Set ON/OFF by selecting META DATA → RECORD.

Selecting the USER CLIP NAME recording method

Select META DATA → USER CLIP NAME from the menu bar to select the recording method. Two options are available: TYPE1 and TYPE2.

- TYPE1 (factory setting)

	USER CLIP NAME to be recorded
If clip metadata has been read in	Uploaded data
If no clip metadata has been read in or if the setting for recording clip metadata has been turned off	Same as GLOBAL CLIP ID (UMID data)

- TYPE2

	USER CLIP NAME to be recorded
If clip metadata has been read in	Uploaded data + COUNT value*
If no clip metadata has been read in or if the setting for recording clip metadata has been turned off	Same as CLIP NAME

* The COUNT value is indicated as a four-digit number. The COUNT value is incremented each time a new clip is captured if clip metadata has been read in and TYPE2 has been selected as the recording method. The COUNT value can be reset using the following procedure.
Select METADATA → PROPERTY → USER CLIP NAME. Select “COUNT RESET” with the cursor and press the SET button to reset the COUNT value to 1.

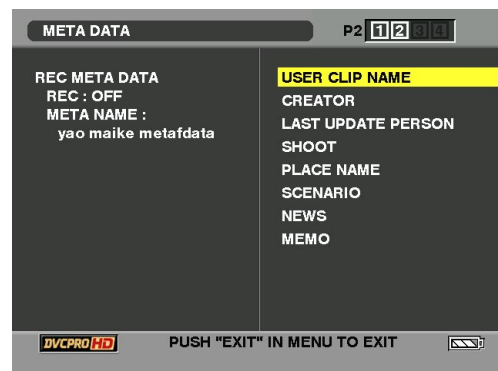

<Note>

When a P2 card with a memory capacity of 8 GB or more is used in this unit and a one-time continuous recording exceeds the prescribed duration (approx. 5 minutes for DVCPRO HD, approx. 10 minutes for DVCPRO50, or approx. 20 minutes for DVCPRO/DV) or when a one-time recording extends over more than one P2 card, the recording concerned will automatically be undertaken as a separate clip. At this time, each clip will be provided with its own COUNT value.

■ Example of recording (DVCPRO50) a clip on one P2 card:

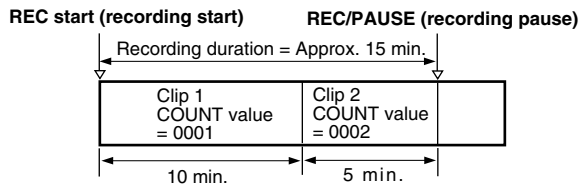

■ Example of recording a clip on two P2 cards:

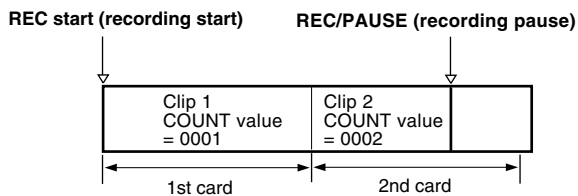

If the clip thumbnails are displayed as shown in the example above or their properties are indicated using a P2 device, the thumbnail and COUNT value of clip 1 will be displayed.

Clear the uploaded metadata

Select META DATA → INITIALIZE, and press the SET button. Select “YES” when the confirmation screen is displayed.

Displaying loaded metadata

Select METADATA → PROPERTY and press the SET button to display the metadata recorded in this unit.

Formatting P2 and SD Memory Cards

Formatting a P2 Card

- 1 Press the MODE button to enter the MCR mode.**
 - The thumbnail screen appears on the LCD monitor.
- 2 Press the thumbnail menu button to open the menu.**
- 3 From the menu bar, select OPERATION → FORMAT.**
 - The following screen appears. Select the slot number for the P2 card you want to format.
 - Select EXIT if formatting is not required.

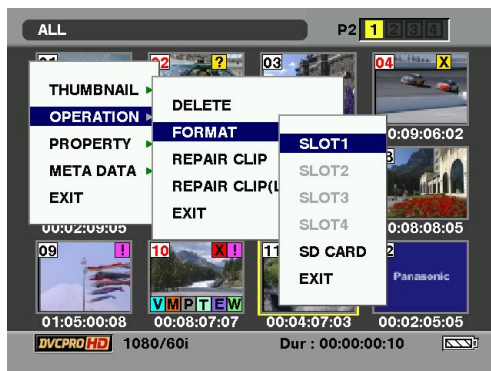

- 4 Use the CURSOR and SET buttons to select YES in the screen that confirms whether you want to format the card.**
 - The selected P2 card is formatted.

Formatting SD memory cards

SD memory cards can also be formatted from the thumbnail screen. With an SD memory card inserted into the camera-recorder, perform the following operation:

- 1 Press the MODE button to enter the MCR mode.**
 - The thumbnail screen appears on the LCD monitor.
- 2 Press the thumbnail menu button to open the menu.**
- 3 Select OPERATION → FORMAT.**
 - The following screen appears. Select "SD-CARD".
 - Select "EXIT" if formatting is not required.

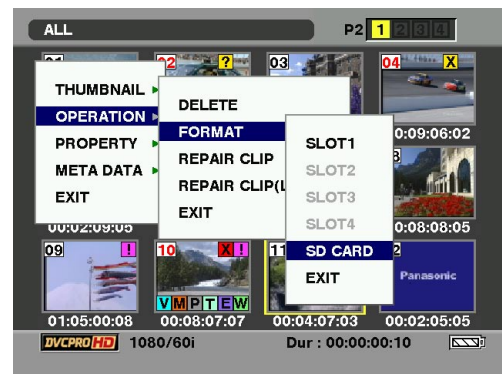

- 4 Use the CURSOR and SET buttons to select YES in the screen that confirms whether you want to format the card.**
 - The SD memory card is formatted.

<Note>

- SD memory cards can also be formatted from the menu screen.
For more information, see [Formatting, Writing and Reading an SD memory card] (page 78).
- For an SDHC card, the space of 32 KB is already used.

Properties

The clip's properties and the P2 card's status are displayed.

Clip Property

Select PROPERTY → CLIP PROPERTY.
The following screen appears.



- 1 Clip number
- 2 Thumbnail
- 3 Slot number
- 4 Clip information

Various indicators that have been added to the clip and also various kinds of data are displayed. (L appears if the P2 card is writeprotected)

- **CLIP NAME:** Clip name
- **START TC:** Time code value when recording started
- **START UB:** User's bit value when recording started
- **DATE:** Date when the recording was made
- **TIME:** Time when recording started
- **DURATION:** Clip length
- **V_FORMAT:** Video signal format
- **FRAME RATE:** Playback frame rate
- **REC RATE:** Recording frame rate

This display appears when recording using a setting for the FRAME RATE item on the SCENE FILE screen other than the default during 720P/24PN or 720P/30PN recording operation.

5 Clip metadata

The video and audio formats, videographer information and other detailed data are displayed here. The audio format is only indicated for 1 to 4CH. Use the CURSOR button to select the item and press the SET button. (For details on the clip metadata, see [Setting of Clip Meta Data] (page 109).)

P2 Card Status Display

P2 Card Status Display Settings

Select PROPERTY → CARD STATUS to set the desired indication mode (remaining free space or used memory capacity) for the P2 card status display.

- 1 Press the **MODE** button to enter the **MCR** mode.
 - The thumbnail screen appears on the LCD monitor.
- 2 Press the thumbnail menu button to open the menu.
- 3 Select **PROPERTY** → **PROPERTY SETUP** → **P2CARD CAP.**
 - The following screen appears. Select the P2 card status display settings from the P2 CARD CAP menu option.

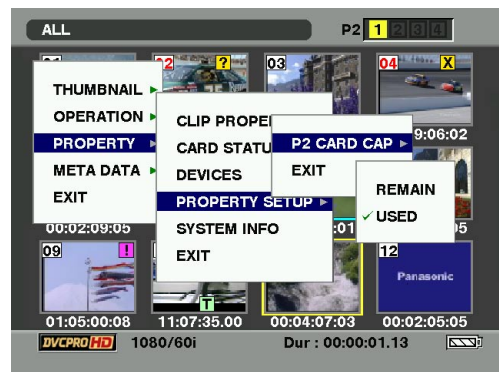

- **REMAIN:** Show remaining free space on the P2 card as the P2 card status display.
- **USED:** Show used memory capacity on the P2 card as the P2 card status display.

<Note>

The factory setting for this function is **REMAIN**.

Contents of P2 Card Status Display Settings

Select PROPERTY → CARD STATUS. The following screen appears.

■When “REMAIN” is selected:

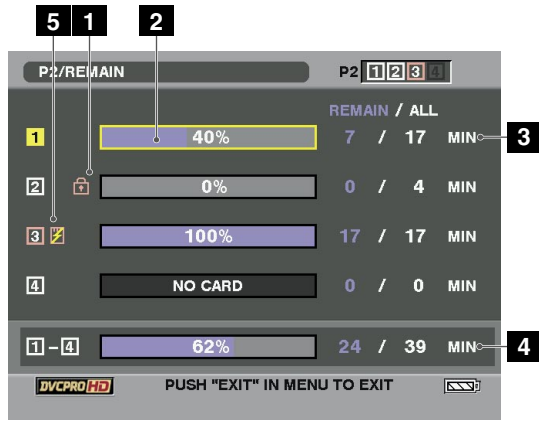

1 Write-protect Mark

The mark appears if the P2 card is write-protected.

2 P2 Card Status (remaining free space)

The remaining memory capacity of the P2 card is indicated by a bar graph and percentage. The bar graph indicator moves to the left as the remaining free space decreases.

The following indications may appear, depending on the card status:

- **FORMAT ERROR:**

An unformatted P2 card is inserted.

- **NOT SUPPORTED:**

An unsupported card is inserted in the camera.

- **NO CARD:**

P2 cards are not inserted.

Press the SET button to view the following data for the card in the selected slot (indicated in yellow numbers).

- **BRAND:** maker name

- **MODEL NO.:** model number

- **SERIAL NO.:** serial number

- **USER ID:** user ID

- **WARNING:** DIR ENTRY NG (The directory structure on the P2 card is not supported.)
RUN DOWN CARD (The maximum number of overwrites on the P2 card has been exceeded.)

3 P2 Card Remaining Capacity/Total Capacity

Displays the P2 card remaining capacity and total capacity in minutes.

The total of the remaining memory capacity for each P2 card that is displayed may not match the actual total remaining memory capacity for the P2 cards because only the figure in minute is displayed.

4 Total remaining memory capacity for all cards

- Displays the total remaining free space for all 4 slots.

Please note that the remaining capacity of a write-protected P2 card is not included in the total remaining capacity.

- When REC FUNCTION (RECORDING SETUP) is set to LOOP, the total remaining memory capacity for all cards indicates the minimum guaranteed recording time for the loop recording. When “REMAIN” is selected, the value of this indication is smaller than the actual possible recording time.

5 Warning card mark

The mark appears when the following P2 cards are inserted.

- **DIR ENTRY NG**

The directory structure on the P2 card is not supported.

- **RUN DOWN CARD**

The maximum number of overwrites on the P2 card has been exceeded.

Use the **2** P2 card status to check the nature of the warning.

■When “USED” is selected:

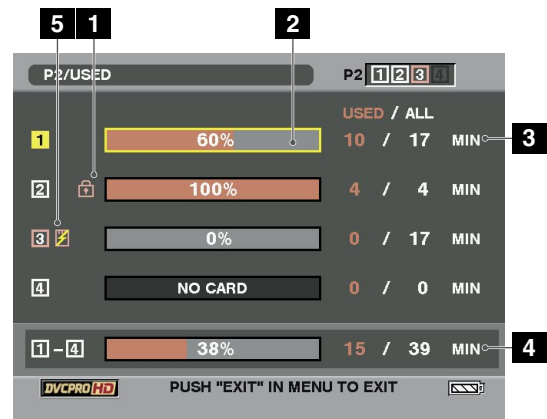

1 Write-protect Mark

The mark appears if the P2 card is write-protected.

2 P2 Card Status (used memory capacity)

The used memory capacity of the P2 card is indicated by a bar graph and a percentage figure. The bar graph indicator moves to the right as the used memory capacity increases.

The following indications may appear, depending on the card status:

- **FORMAT ERROR:**

An unformatted P2 card is inserted.

- **NOT SUPPORTED:**

An unsupported card is inserted in the camera.

- **NO CARD:**

P2 cards are not inserted.

Press the SET button to view the following data for the card in the selected slot (indicated in yellow numbers).

- **BRAND:** maker name

- **MODEL NO.:** model number

- **SERIAL NO.:** serial number
- **USER ID:** user ID
- **WARNING:** DIR ENTRY NG (The directory structure on the P2 card is not supported.)
RUN DOWN CARD (The maximum number of overwrites on the P2 card has been exceeded.)

3 P2 Card memory capacity/Total Capacity
Displays the used memory capacity on a P2 card and the total capacity, in minutes. Because fractions are truncated, the figure shown for used memory capacity on a P2 card may differ from the figure for total capacity. The used memory capacity of a write-protected P2 card is displayed as 100%.

4 Total used memory capacity for all slots

- Displays the total used memory capacity for all 4 slots.
- When REC FUNCTION (RECORDING SETUP) is set to LOOP, this indication shows the minimum guaranteed recording time for the loop recording. When “USE” is selected, the value of this indication is greater than the actual used memory capacity.

5 Warning card mark
The mark  appears when the following P2 cards are inserted.

- **DIR ENTRY NG**
The directory structure on the P2 card is not supported.
- **RUN DOWN CARD**
The maximum number of overwrites on the P2 card has been exceeded.

Use the **2** P2 card status to check the nature of the warning.

standard (SUPPORTED/NOT SUPPORTED).

<Note>

For an SDHC card, the space of 32 KB remains used even after being formatted.

- **USED:** Space used
- **BLANK:** Space available
- **TOTAL:** Total space
- **NUMBER OF CLIPS:** Number of clips
- **PROTECT:** This indicates that the SD memory card is write protected.

Confirmation of Metadata Upload

- The contents of the metadata upload file that is read from the SD memory card can be checked.
- Select META DATA → PROPERTY. The following screen appears:

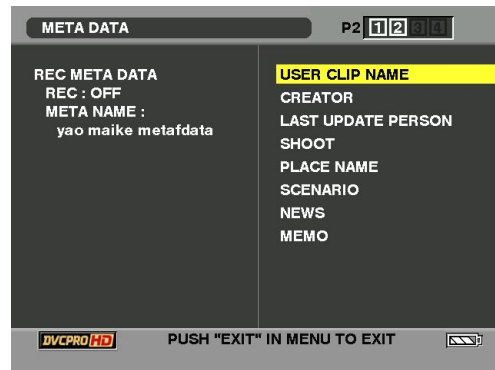

For more information on each item, see [Setting of Clip Meta Data] (page 109).

- The META NAME is the meta data name written in the meta data upload file, and is not recorded in the clip.

SD memory card Status Display

The status display enables a confirmation of the SD memory card formatted condition, available memory capacity etc.

Select PROPERTY → DEVICES → SD CARD.

Screen showing SD memory card data

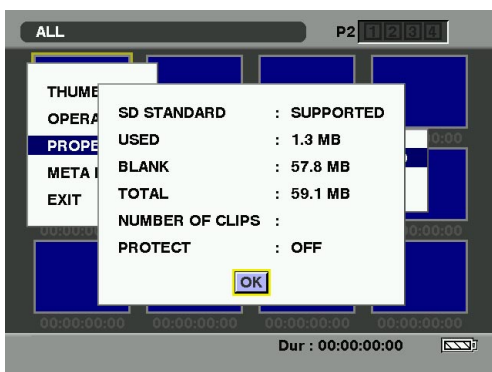

- **SD STANDARD:** This indicates whether the SD memory card was formatted in compliance with the SD

Chapter 7 Menu Operations

Viewfinder and LCD Menus

Using the menus

Use the setup menus to change the settings to suit the scenes you are shooting or what you are recording.

- If the thumbnail menu is displayed, press the THUMBNAIL button to release the display.
- The menu items indicated in the blue characters cannot be used.

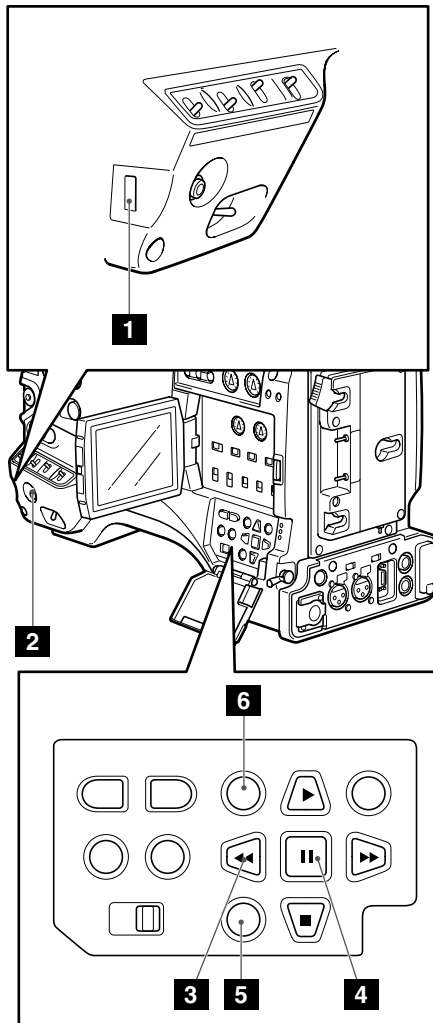

- 1 JOG dial button
- 2 MENU button
- 3 CURSOR buttons
- 4 SET button
- 5 Thumbnail menu button
- 6 Thumbnail button

1 When the unit is in other than playback or recording mode, press the MENU button.

- Hold down the front menu button for 1 second or longer.
- The function screen appears in the viewfinder and on the LCD screen.

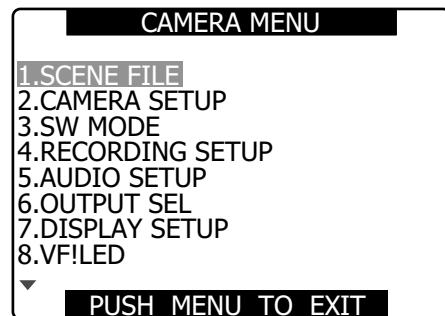

2 Use the JOG dial button (or the Up and Down cursor buttons) to highlight the function you want to change.

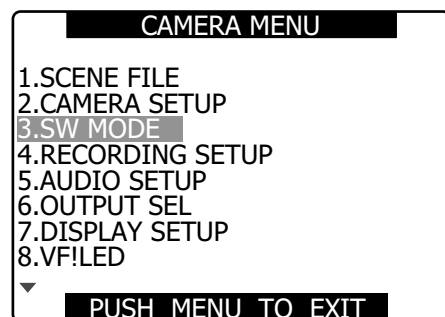

3 Press the JOG dial button (or the SET button) to display the items.

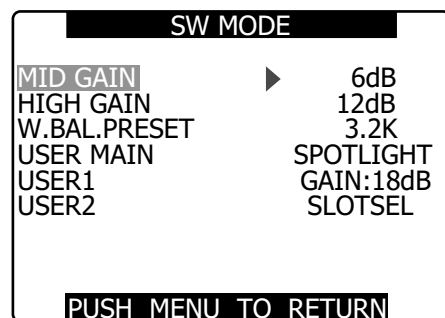

- 4** Use the JOG dial button (or the Up and Down cursor buttons) to highlight the item you want to change.

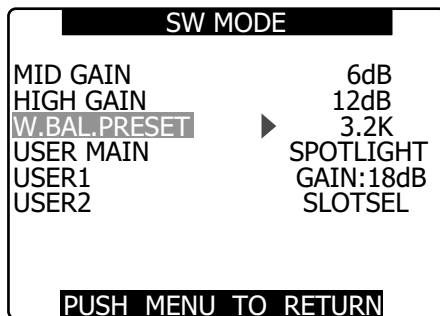

- 5** Use the JOG dial button (or the SET button) to change the setting value.

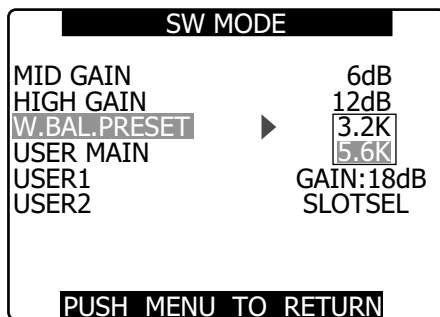

- 6** To change other settings, repeat steps 4 and 5.

- When you finish, press the MENU button to return to the function screen.

- 7** To change other functions, repeat steps 2 to 5.

- To exit the function screen and return to the normal screen, press the MENU button again.

<Note>

Direct close function

When the MENU button is pressed and held down after making a menu setting closes the setting menu screen without first returning to the previous setting menu.

Initializing the menu settings

The menu settings contain both the user file settings and the scene file settings. You can initialize them separately.

To initialize the user file (i.e. all the settings other than the scene file settings)

Select INITIAL in USER FILE of the OTHER FUNCTIONS screen. The current menu settings of user file will return to the factory settings.

To initialize the scene file

From the 6 scene files, select the one you want to initialize with the SCENE FILE dial. Then in the SCENE FILE screen, LOAD/SAVE/INIT, select INITIAL.

The settings for only the selected scene file are returned to the factory settings.

- This does not effect the other scene files.

Setup menu structure

Camera (CAM) mode menu

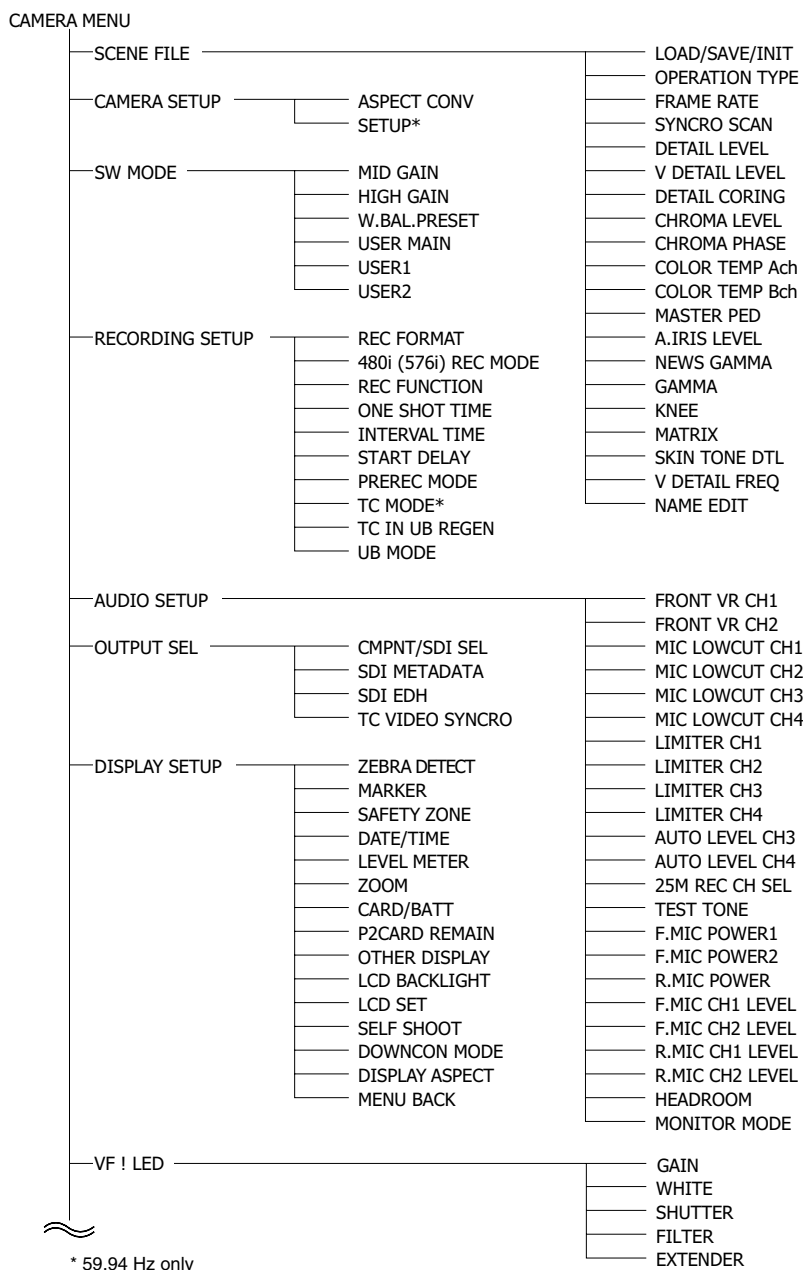

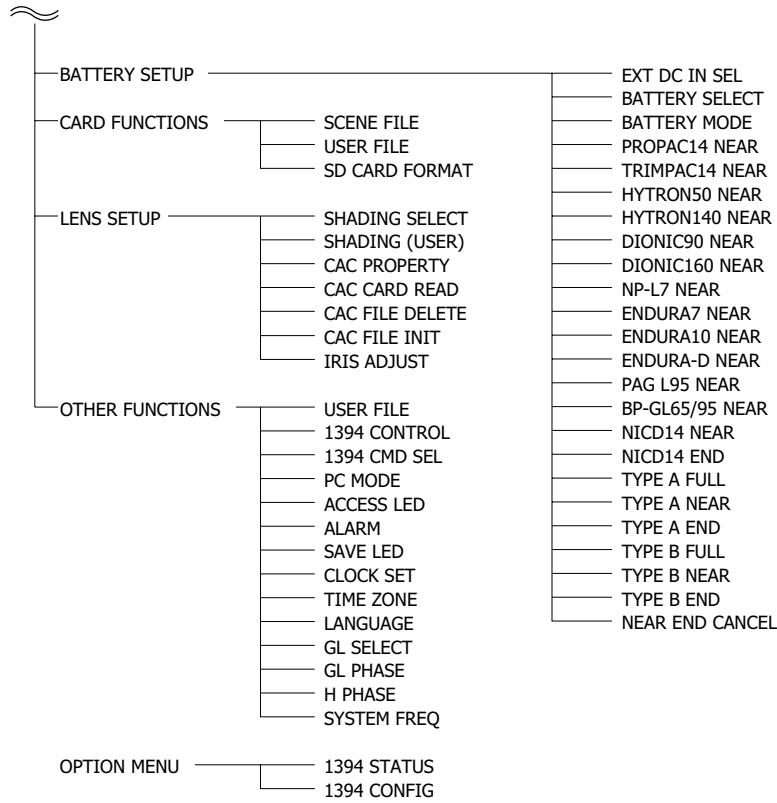

MCR mode menu

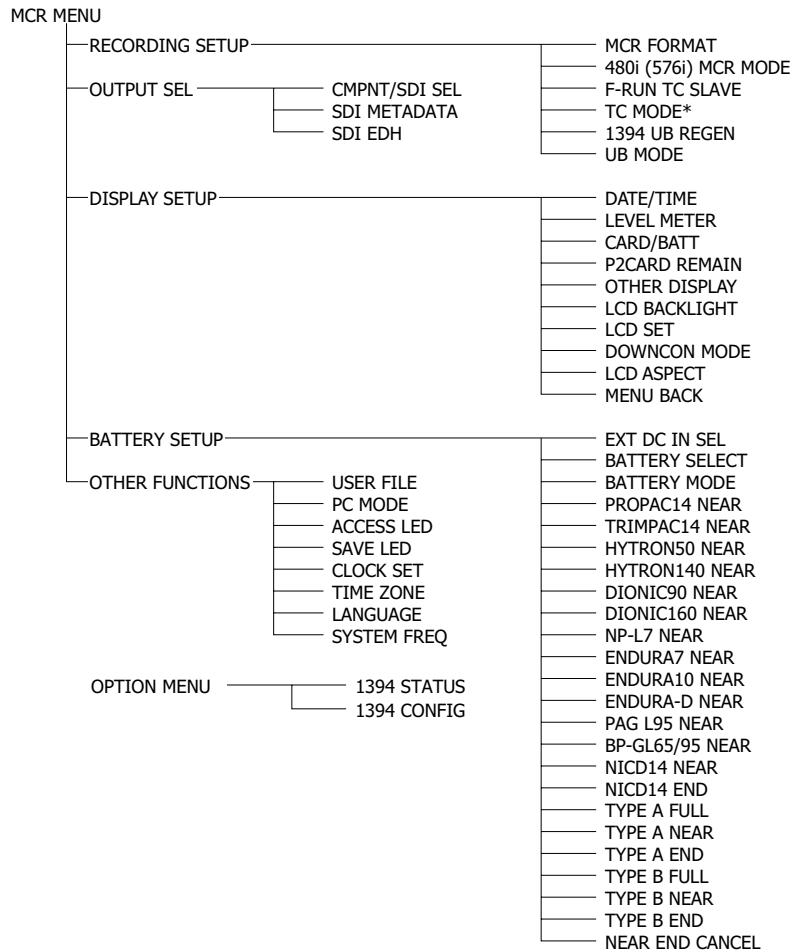

* 59.94 Hz only

Setup menu list

■ Marks used in the list

CAM: Indicates that the item can be set in the CAMERA mode.

MCR: Indicates that the item can be set in the MCR mode.

CAM/MCR: Indicates that the item can be set in both CAMERA and MCR modes.

SCENE FILE screen

Item	Description of settings (Items in bold are factory settings.)
LOAD/SAVE/INIT CAM	Saves, loads and initializes scene files. ●----(No operation), LOAD (Load), SAVE (Save), INITIAL (Initialize)
OPERATION TYPE CAM	Switches the shutter and frame rate operation to the video type or film type. ● VIDEO CAM: SYNCRO SCAN is set in 1/n increments. The frame rate is dependent on the REC FORMAT. Slow shutter speeds are enabled. Time code is displayed at 30 frames except at 24PN. (25 frames at 50 Hz) ● FILM CAM: SYNCRO SCAN is displayed as an angle. FRAME RATE can be used to vary the frame rate. Slow shutter speeds are disabled. The time code indication is fixed at 24 hour display. (25 frames at 50 Hz)
FRAME RATE CAM	Selects the shooting interval and exposure time when 720P and FILM CAM TYPE is selected. The default values for the REC FORMAT 720/60, 720/30 and 720/24 are fixed at 60P, 30P and 24P, respectively. ●59.94Hz SYSTEM DEFAULT , 12, 18, 20, 22, 24, 26, 30, 32, 36, 48, 60 ●50Hz SYSTEM DEFAULT , 12, 18, 20, 23, 25, 27, 30, 32, 37, 48, 50
SYNCRO SCAN CAM	Adjusts the synchro scan shutter speed used for shooting images on a TV screen, etc. Turn and hold the JOG dial button (operation button) upwards or downwards to increase the speed at which the set values change. ●When VIDEO CAM is selected as the OPERATION TYPE option setting: • 60P/60i: 1/60.0 ... 1/249.8 • 50P/50i: 1/50.0 ... 1/248.9 • 30P/30PN: 1/30.1 ... 1/48.0 ... 1/249.8 • 25P/25PN: 1/25.0 ... 1/48.0 ... 1/248.9 • 24P/24PA/24PN: 1/24.0 ... 1/48.0 ... 1/249.8 ●When FILM CAM is selected as the OPERATION TYPE option setting: • The shutter speed is displayed as an angle such as "180.0d." • 10.0 deg ... 180.0 deg ... 360.0 deg (the angle can be changed in increments of 0.5 degrees)
DETAIL LEVEL CAM	Adjusts the level of the image outline correction (in the horizontal and vertical directions). ●Adjustable range: - 7 ... 0 ... + 7
V DETAIL LEVEL CAM	Adjusts the level of outline correction in the vertical direction. ●Adjustable range: - 7 ... 0 ... + 7
DETAIL CORING CAM	Adjusts the level of noise reduction of the detail signal. ●Adjustable range: - 7 ... 0 ... + 7 Set to - for a clearer image. Noise increases slightly. Set to + to reduce noise.
CHROMA LEVEL CAM	Adjusts the chroma level. ●Adjustable range: - 7 ... 0 ... + 7
CHROMA PHASE CAM	Makes fine adjustments to the chroma phase. ●Adjustable range: - 7 ... 0 ... + 7
COLOR TEMP Ach CAM	Makes fine adjustments to the color temperature (after white balance adjustment of Ach). ●Adjustable range: - 7 ... 0 ... + 7
COLOR TEMP Bch CAM	Makes fine adjustments to the color temperature (after white balance adjustment of Bch). ●Adjustable range: - 7 ... 0 ... + 7
MASTER PED CAM	Adjusts the black master pedestal that serves as the video reference. ●Adjustable range: - 100 ... 0 ... + 100
A. IRIS LEVEL CAM	Sets the desired AUTO IRIS level. ●Adjustable range: - 10 ... 0 ... + 10

Item	Description of settings (Items in bold are factory settings.)
NEWS GAMMA* CAM	Selects the news gamma curve. (Only valid for 1080i/60i, 50i, 720/50P, 50P, 480/60i and 576/50i) ●ON, OFF
GAMMA* CAM	Selects the gamma curves other than the news gamma curve. ● HD NORM : This gamma setting is suitable for HD shooting. ● LOW : Makes a mellow image using the gamma curve which has a gentle incline in lowbrightness curve. The contrast sharpens. ● SD NORM : This is the standard gamma curve for SD shooting. ● HIGH : Expands the tone of dark parts and makes a brighter image using the gamma curve which has a sharp incline in lowbrightness curve. The contrast softens. ● B.PRESS : Makes the contrast sharper than LOW. ● CINELIKE D : Makes a cinema-like image. ● CINELIKE V : Makes a cinema-like image with emphasized contrast. When you select CINELIKE gamma, we recommend to set the lens aperture lower than normal image level (approximately 1/2) to enjoy the full benefit of the function.
KNEE CAM	To avoid overexposure, select the compression level (knee point) of the high intensity video signals received through CCD. ● LOW : Low setting (Compression starts at approx. 80 %.) ● MID: Medium setting (Compression starts at approx. 90 %.) ● HIGH : High Setting (Compression starts at approx. 100 %.) This setting cannot be changed when GAMMA is enabled and CINELIKE gamma is selected.
MATRIX CAM	Selects the MATRIX table suitable for the desired color expression during shooting. ● NORM1: Suitable for shooting in the open air or under a halogen lamp. ● NORM2 : Suitable for brighter colors than the NORM1 mode. ● FLUO : Suitable for shooting under fluorescent light indoors. ● CINELIKE : Suitable for cinema-like image.
SKIN TONE DTL CAM	Sets the skin tone details. Select ON to reduce the skin tone details and soften the skin tone. ●ON, OFF
V DETAIL FREQ CAM	Sets the vertical detail for shooting in the progressive mode at 480/24P, 24PA 30P 576/25P. ● THIN: Makes the detail thin. ● MID : Makes the detail slightly thicker. ● THICK : Makes the detail thicker. When images were shot in the progressive mode in which the vertical detail is set as "THIN" or "MID" and are played on a monitoring television (60i interlace), you will see flickers caused on horizontal lines and almost horizontal oblique lines. When playing back images in the progressive mode or when editing images or performing other postprocessing, images with a higher resolution will be obtained with the THIN or MID setting than with the THICK setting.
NAME EDIT CAM	Edits the name of the selected scene file you have selected with the scene file dial.

* The gamma curve is fixed to CINELIKE V at a gain setting of 18 dB.

CAMERA SETUP screen

Item	Description of settings (Items in bold are factory settings.)
ASPECT CONV CAM	Selects the aspect ratio of the image you record in 480i/576i (SD mode) format. This item cannot be selected when the 1080i or 720P recording format is used. ● SIDE CROP (Side crop) , LETTER BOX, SQUEEZE
SETUP (only when set to 59.94 Hz) CAM	Selects the setup level for the 480i video signal. The SETUP menu setting for playback is enabled. ●0 %: Setup is switched to 0 % for both camera output and recording. ● 7.5 %A: Video output is set to 7.5% while D terminal output, SDI output and recording are set to 0%.

SW MODE screen

Item	Description of settings (Items in bold are factory settings.)
MID GAIN CAM	Sets the gain value assigned to the M position of the GAIN switch. ●0 dB, 3 dB, 6 dB , 9 dB, 12 dB
HIGH GAIN CAM	Sets the gain value assigned to the H position of the GAIN switch. ●0 dB, 3 dB, 6 dB, 9 dB, 12 dB
W.BAL.PRESET CAM	Sets the color temperature assigned to the PRST position of the WHITE BAL switch. ● 3.2 K / 5.6 K
USER MAIN CAM	<p>Selects the function assigned to the USER MAIN button.</p> <ul style="list-style-type: none"> ●REC CHECK: Performs Rec Check. ●SPOTLIGHT: Auto iris control for the spotlight ON/OFF ●BACKLIGHT: Auto iris control for the backlight compensation ●BLACKFADE: Blackfade ●WHITEFADE: Whitefade ●GAIN: 18 dB: <ul style="list-style-type: none"> • Press the button to set the gain value to 18 dB. This setting takes effect with the 60i and 60P recording formats only. It is not valid when the recording frame rate is less than 22 fps or when the slow shutter mode (1/15) is established. • When the gain value is set to 18 dB or set from 18 dB to another value, the image can be disordered for a moment. <ul style="list-style-type: none"> ●TEXT MEMO: Text memo recording ●SLOT SEL: Selects one of the P2 card slots. ●SHOT MARK: Shot mark recording ●LVL METER: Displays the level for channels other than those set in the menu. ●MARKER: Displays markers. ●LCD REV: Displays an upside down and reversed image on the LCD.
USER1 CAM	Selects the function assigned to the USER1 button. The settings are the same as USER MAIN above. Factory setting: BACKLIGHT
USER2 CAM	Selects the function assigned to the USER2 button. The settings are the same as USER MAIN above. Factory default: LVL METER

RECORDING SETUP screen

Item	Description of settings (Items in bold are factory settings.)
REC FORMAT CAM	Selects the recording format for P2 card. <ul style="list-style-type: none"> ●59.94Hz System: 1080i/60i, 1080i/30P, 1080i/24P, 1080i/24PA, 720P/60P, 720P/30P, 720P/24P, 720P/30PN, 720P/24PN, 480i/60i, 480i/30P, 480i/24P, 480i/24PA ●50 Hz System: 1080i/50i, 1080i/25P, 720P/50P, 720P/25P, 720P/25PN, 576i/50i, 576i/25P
480i (576i) REC MODE CAM	Selects the 480i (576i) recording mode. Enabled during SD mode recording. <ul style="list-style-type: none"> ●DVCPRO50 / DVCPRO/DV
REC FUNCTION CAM	Selects the special recording mode. <ul style="list-style-type: none"> ●NORMAL, INTERVAL, ONE SHOT, LOOP
ONE SHOT TIME CAM	Selects the one-shot recording time. <ul style="list-style-type: none"> ●1F, 2F, 4F, 8F, 16F, 1s
INTERVAL TIME CAM	Sets the interval time (INT) for interval recording (INTERVAL REC). <ul style="list-style-type: none"> ●2F, 4F, 8F, 16F, 1s, 2s, 5s, 10s, 30s, 1m, 5m, 10m
START DELAY CAM	Sets the START delay time for INTERVAL REC and ONE SHOT REC. <ul style="list-style-type: none"> ●ON, OFF
PREREC MODE CAM	Sets PRE RECORDING to ON or OFF. (Fixed to 3 seconds for HD and 7 seconds for SD) <ul style="list-style-type: none"> ●ON, OFF
TC MODE (only when set to 59.94 Hz) CAM/MCR	Selects the time code correction mode when recording the time code output by the internal time code generator. <ul style="list-style-type: none"> ●DF: Uses the drop frame mode. ●NDF: Uses the non-drop frame mode. <p>The non-drop frame mode is used when a frame rate of 24P, 24PA, or 24PN is selected in a recording format regardless of TC MODE setting.</p>
TC IN UB REGEN CAM	Selects the user bits to be recorded when recording signals from a device connected to the TC IN connector. <ul style="list-style-type: none"> ●ON: Records the user bits of the signal input to the TC IN connector. ●OFF: Records the user bits selected in the menu option UB MODE. <ul style="list-style-type: none"> • Setting this option to ON prioritizes the input signal over the settings made in the menu option UB MODE. • No user bits are recorded when the input signal does not contain any user bits. • Settings of the menu option UB MODE are used when no signal is input to the TC IN connector.
UB MODE CAM/MCR	Set the content for user information. <ul style="list-style-type: none"> ●USER: Records the information of user. ●TIME: Records the time at recording. ●DATE: Records the date at recording. ●TCG: Records the values of the time code generator. ●FRM. RATE: Records the frame rate information for frame conversion. <pre> ** 0 ** ** ** a b c d </pre> <p>a: Checking information for user information b: Frame sequence No. • 0 to 4 are displayed in 24P/24P (ADV) mode. • F is displayed in the modes other than above. c: Frame rates • Frame rate (60/30/24) • I/P ID • Conversion data • Frame rate coefficient d: Recording management data • Frame update information • REC START/STOP information</p> <p>When connecting the HD SDI output to an external device (with HD SDI input) for backing up data, set UB MODE to FRM.RATE to enable control of recording start/stop from the camera. The external device has to be set up when automatic recording is desired. For details, refer to the Operating Instructions supplied with the device.</p>
MCR FORMAT MCR	Selects playback or 1394 input format. <ul style="list-style-type: none"> ●When operating at 59.94 Hz: 1080i/60i, 720P/60P, 720P/30PN, 720P/24PN, 480i/60i ●When operating at 50 Hz: 1080i/50i, 720P/50P, 720P/25PN, 576i/50i <p>720P/30PN, 24PN and 25PN are available only for playback.</p>
480i (576i) MCR MODE MCR	Selects the 480i (576i) playback mode, or 1394 input format. <ul style="list-style-type: none"> ●DVCPRO50 / DVCPRO/DV

Item	Description of settings (Items in bold are factory settings.)
F-RUN TC SLAVE MCR	Selects whether slave-locked time code input via the 1394 connector is used or not when the TCG switch is set to F-RUN. <ul style="list-style-type: none"> ●1394: Records with the slave-locked time code via the 1394 connector. ●OFF: Records with the time code selected by the TC MODE item or the TCG switch.
1394 UB REGEN MCR	Selects the user bits to be recorded when recording signals from a device connected to the 1394 connector. <ul style="list-style-type: none"> ●ON: Records the user bits of the signal input to the 1394 connector. ●OFF: Records the user bits selected in the menu option UB MODE. <ul style="list-style-type: none"> • Setting this option to ON prioritizes the input signal over the settings made in the menu option UB MODE. • No user bits are recorded when the input signal does not contain any user bits. • The UB MODE settings are used when no signal is input to the TC IN connector.

AUDIO SETUP screen

Item	Description of settings (Items in bold are factory settings.)
FRONT VR CH1 CAM	Selects the function of the FRONT AUDIO LEVEL control of CH1 input. <ul style="list-style-type: none"> ●FRONT: The front control controls FRONT1 and FRONT2 inputs. ●REAR: The FRONT AUDIO LEVEL control controls REAR1 input. ●ALL: The FRONT AUDIO LEVEL control controls both FRONT1 and REAR1 inputs. ●OFF: The FRONT AUDIO LEVEL control does not control the input signal. This control is disabled when the AUDIO SELECT CH1 switch is set to AUTO.
FRONT VR CH2 CAM	Selects the function of the FRONT AUDIO LEVEL control of CH2 input. <ul style="list-style-type: none"> ●FRONT: The FRONT AUDIO LEVEL control controls FRONT2 input. ●REAR: The FRONT AUDIO LEVEL control controls REAR2 input. ●ALL: The FRONT AUDIO LEVEL control controls both FRONT2 and REAR2 inputs. ●OFF: The FRONT AUDIO LEVEL control does not control the input signal. This control is disabled when the AUDIO SELECT CH2 switch is set to AUTO.
MIC LOWCUT CH1 CAM	Turns on and off the CH1 microphone lowcut filter. <ul style="list-style-type: none"> ●ON, OFF
MIC LOWCUT CH2 CAM	Turns on and off the CH2 microphone lowcut filter. <ul style="list-style-type: none"> ●ON, OFF
MIC LOWCUT CH3 CAM	Turns on and off the CH3 microphone lowcut filter. <ul style="list-style-type: none"> ●ON, OFF
MIC LOWCUT CH4 CAM	Turns on and off the CH4 microphone lowcut filter. <ul style="list-style-type: none"> ●ON, OFF
LIMITER CH1 CAM	Turns on and off the CH1 limiter. <ul style="list-style-type: none"> ●ON, OFF
LIMITER CH2 CAM	Turns on and off the CH2 limiter. <ul style="list-style-type: none"> ●ON, OFF
LIMITER CH3 CAM	Turns on and off the CH3 limiter. <ul style="list-style-type: none"> ●ON, OFF
LIMITER CH4 CAM	Turns on and off the CH4 limiter. <ul style="list-style-type: none"> ●ON, OFF
AUTO LEVEL CH3 CAM	Selects the method for selecting CH3 level. <ul style="list-style-type: none"> ●ON: Automatically controls CH3 level. ●OFF: Enables dial control of CH3 level via dial.
AUTO LEVEL CH4 CAM	Selects the method for selecting CH4 level. <ul style="list-style-type: none"> ●ON: Automatically controls CH4 level. ●OFF: Enables dial control of CH4 level via dial.
25M REC CH SEL CAM	Selects the audio channels to be recorded in the DVCPRO and DV formats. <ul style="list-style-type: none"> ●2CH: Only recorded on CH1 and CH2. ●4CH: Recorded on channels 1 to 4.
TEST TONE CAM	Selects the test signal. <ul style="list-style-type: none"> ●OFF: Disables test tone output. ●NORMAL: Outputs test tones to channels 1, 2, 3 and 4 when the OUTPUT/AUTO KNEE selector switch is set to BARS and the AUDIO IN switch CH1 is set to FRONT1. ●ALWAYS: Outputs test tones to channels 1, 2, 3 and 4 when the OUTPUT/AUTO KNEE selector switch is set to BARS. ●CH SEL: Outputs test tones to channels selected by setting AUDIO IN switch CH1 to FRONT1 or switch CH2 to FRONT with the OUTPUT/AUTO KNEE selector switch set to BARS. When NORMAL or CH SEL is selected, setting the AUDIO IN switch CH1 to FRONT2 will not output a test tone.
F.MIC POWER1 CAM	Turns on and off the phantom power supply for the front microphone connected to CH1. <ul style="list-style-type: none"> ●ON, OFF

Item	Description of settings (Items in bold are factory settings.)
F.MIC POWER2 CAM	Turns on and off the phantom power supply for the front microphone connected to CH2. ●ON, OFF
R.MIC POWER CAM	Turns on and off the phantom power supply for the rear microphone. ●ON, OFF
F.MIC CH1 LEVEL CAM	Selects the input level for the front microphone connected to CH1. ●-40 dB, -50 dB , -60 dB
F.MIC CH2 LEVEL CAM	Selects the input level for the front microphone connected to CH2. ●-40 dB, -50 dB , -60 dB
R.MIC CH1 LEVEL CAM	Selects the input level for the rear microphone connected to CH1. ●-50 dB, -60 dB
R.MIC CH2 LEVEL CAM	Selects the input level for the rear microphone connected to CH2. ●-50 dB, -60 dB
HEADROOM CAM	Sets the headroom (standard level). ●59.94Hz System: 18 dB, 20 dB ●50 Hz System: 18 dB , 20 dB
MONITOR MODE CAM	Switches speaker and earphone audio delay. ●LIVE: No audio delay ●RECORDING: Recorded (delayed) audio

OUTPUT SEL screen

Item	Description of settings (Items in bold are factory settings.)
CMPNT/SDI SEL CAM/MCR	Selects D or SDI connector. ●59.94Hz system: AUTO , 1080i, 480i ●50 Hz system: AUTO , 1080i, 576i If this item is set to AUTO, the REC FORMAT setting will be applied.
SDI METADATA CAM/MCR	Turns on and off metadata superimposition onto the SDI signal. ●ON, OFF
SDI EDH CAM/MCR	Turns on and off EDH superimposition onto the SD-SDI signal. ●ON, OFF
TC VIDEO SYNCRO CAM	Selects whether to delay time code output. ●TC IN: Outputs the input from the TC IN connector without delay. ●VIDEO: Outputs the time code with delay according to the output video.

DISPLAY SETUP screen

Item	Description of settings (Items in bold are factory settings.)
ZEBRA DETECT CAM	Selects the brightness level of the leftleaning zebra patterns on the screen. ●50 %, 55 %, 60 %, 65 %, 70 %, 75 %, 80 % , 85 %, 90 %, 95 %, 100 %, 105 %
MARKER CAM	Turns on or off the center marker display. ●ON, OFF Set this item to ON to display the marker. The brightness status is also displayed.
SAFETY ZONE CAM	Sets SAFETY ZONE. ●OFF, 90 % , 4:3
DATE/TIME CAM/MCR	Sets whether to display the date and time on the screen and whether to output from the VIDEO IN/OUT jack. ●OFF: The date and time are not displayed. ●TIME: The time is displayed. ●DATE: The date is displayed. ●TIME&DATE: The time and date are displayed.
LEVEL METER CAM/MCR	Select ON to display the audio level meter. ●ON, OFF
ZOOM CAM	Turns zoom value display on and off. ●ON, OFF Displays zoom values between Z00 to Z99.
CARD/BATT CAM/MCR	Turns on and off card and battery remaining level. ●ON, OFF
P2CARD REMAIN CAM/MCR	Switches the indication of remaining P2 memory card capacity. ●TOTAL: Indicates total remaining capacity of all cards. ●ONE-CARD: Indicates the remaining capacity of the card that is being recorded.

Item	Description of settings (Items in bold are factory settings.)
OTHER DISPLAY CAM/MCR	Select how much information to display on the screen. ●OFF, PARTIAL , ALL
LCD BACKLIGHT CAM/MCR	Adjusts the backlight of the LCD monitor. Select HIGH for brighter backlight. ●HIGH, NORMAL
LCD SET CAM/MCR	Adjusts the display level of the images on the LCD monitor. ●LCD COLOR LEVEL, LCD BRIGHTNESS ,LCD CONTRAST Select to set respective value using the right and left cursor keys.
SELF SHOOT CAM	Selects the LCD mirror mode for self-portrait shooting. Select MIRROR to reverse left and right at self-portrait shooting. ●NORMAL, MIRROR
DOWNCON MODE CAM/MCR	Switches down-conversion output mode. ●SIDE CROP: Side-crop mode ● LETTER BOX: Letter-box mode ●SQUEEZE: Squeeze mode
LCD ASPECT CAM/MCR	Selects the aspect ratio of the LCD monitor and the viewfinder. Operates when the recording format is set to the SD format. ● AUTO: Changes automatically to the appropriate ratio according to the recording or play mode information. ●4:3: Fixed at 4:3. Black bands appear at the top and bottom of the screen when images are displayed at a 16:9 aspect ratio. No parts of the images are missing.
MENU BACK CAM/MCR	Selects whether to lower the transparency of the background to make menu text easier to read. ●ON: Lowers background transparency. This function is not available for synchro scan and LCD SET pages. ●OFF: Sets a background transparency of 100%.

VF! LED screen

Item	Description of settings (Items in bold are factory settings.)
GAIN CAM	Sets the conditions (gain value) for lighting the “!” symbol LED in the viewfinder. ●w/o 0 dB: other than 0 dB ●OFF: Off
WHITE CAM	Sets the conditions (white balance value) for lighting the “!” symbol LED in the viewfinder. ●PRST: Preset ●OFF: Off
SHUTTER CAM	Sets the conditions (shutter status) for lighting the “!” symbol LED in the viewfinder. ●ON, OFF
FILTER CAM	Sets the conditions (filter status) for lighting the “!” symbol LED in the viewfinder. ●NG: Abnormal ●No1: No1 ●w/o No1: other than No 1 ●OFF: Off
EXTENDER CAM	Sets the conditions (extender status) for lighting the “!” symbol LED in the viewfinder. ●ON, OFF

BATTERY SETUP screen

Item	Description of settings (Items in bold are factory settings.)
EXT DC IN SEL CAM/MCR	Selects external DC power supply type. ● AC ADPT: AC adapter ●BATTERY: battery
BATTERY SELECT CAM/MCR	Selects battery type. ●PROPAC14, TRIMPAC14, HYTRON50, HYTRON140, DIONIC90 , DIONIC160, NP-L7, ENDURA7, ENDURA10, ENDURA-D, PAG L95, BP-GL65/95, NICD14, TYPE A, TYPE B
BATTERY MODE CAM/MCR	Near end setting ● AUTO: Automatically selects one of the following battery types selected in BATTERY SELECT. PROPAC14, TRIMPAC14, HYTRON50, HYTRON140, DIONIC90, DIONIC160, NP-L7, ENDURA7, ENDURA10, ENDURA-D, PAG L95, BP-GL65/95 ●MANUAL: Manually enter near end voltage.
PROPAC14 NEAR CAM/MCR	Sets near end voltage for PROPAC14 (Adjustable in 0.1 V units). ●Adjustable range: 11.0 ... 13.9 ... 15.0
TRIMPAC14 NEAR CAM/MCR	Sets near end voltage for TRIMPAC14 (Adjustable in 0.1 V units). ●Adjustable range: 11.0 ... 13.6 ... 15.0
HYTRON50 NEAR CAM/MCR	Sets near end voltage for HYTRON50 (Adjustable in 0.1 V units). ●Adjustable range: 11.0 ... 13.7 ... 15.0
HYTRON140 NEAR CAM/MCR	Sets near end voltage for HYTRON140 (Adjustable in 0.1 V units). ●Adjustable range: 11.0 ... 13.1 ... 15.0
DIONIC90 NEAR CAM/MCR	Sets near end voltage for DIONIC90 (Adjustable in 0.1 V units). ●Adjustable range: 11.0 ... 13.5 ... 15.0
DIONIC160 NEAR CAM/MCR	Sets near end voltage for DIONIC160 (Adjustable in 0.1 V units). ●Adjustable range: 11.0 ... 13.0 ... 15.0
NP-L7 NEAR CAM/MCR	Sets near end voltage for NP-L7 (Adjustable in 0.1 V units). ●Adjustable range: 11.0 ... 13.3 ... 15.0
ENDURA7 NEAR CAM/MCR	Sets near end voltage for ENDURA7 (Adjustable in 0.1 V units). ●Adjustable range: 11.0 ... 13.4 ... 15.0
ENDURA10 NEAR CAM/MCR	Sets near end voltage for ENDURA10 (Adjustable in 0.1 V units). ●Adjustable range: 11.0 ... 13.3 ... 15.0
ENDURA-D NEAR CAM/MCR	Sets near end voltage for ENDURA-D (Adjustable in 0.1 V units). ●Adjustable range: 11.0 ... 13.5 ... 15.0
PAG L95 NEAR CAM/MCR	Sets near end voltage for PAG L95 (Adjustable in 0.1 V units). ●Adjustable range: 11.0 ... 13.5 ... 15.0
BP-GL65/95 NEAR CAM/MCR	Sets near end voltage for BP-GL65/95 (Adjustable in 0.1 V units). ●Adjustable range: 11.0 ... 13.3 ... 15.0
NICD14 NEAR CAM/MCR	Sets near end voltage for NICD14 (Adjustable in 0.1 V units). ●Adjustable range: 11.0 ... 13.9 ... 15.0
NICD14 END CAM/MCR	Sets end voltage for NICD14 (Adjustable in 0.1 V units). ●Adjustable range: 11.0 ... 13.5 ... 15.0
TYPE A FULL CAM/MCR	Sets full voltage for TYPE A (Adjustable in 0.1 V units). ●Adjustable range: 12.0 ... 15.7 ... 17.0
TYPE A NEAR CAM/MCR	Sets near end voltage for TYPE A (Adjustable in 0.1 V units). ●Adjustable range: 11.0 ... 13.5 ... 15.0
TYPE A END CAM/MCR	Sets end voltage for TYPE A (Adjustable in 0.1 V units). ●Adjustable range: 11.0 ... 12.8 ... 15.0
TYPE B FULL CAM/MCR	Sets full voltage for TYPE B (Adjustable in 0.1 V units). ●Adjustable range: 12.0 ... 16.0 ... 17.0
TYPE B NEAR CAM/MCR	Sets near end voltage for TYPE B (Adjustable in 0.1 V units). ●Adjustable range: 11.0 ... 13.1 ... 15.0
TYPE B END CAM/MCR	Sets end voltage for TYPE B (Adjustable in 0.1 V units). ●Adjustable range: 11.0 ... 12.5 ... 15.0
NEAR END CANCEL CAM/MCR	Selects whether to cancel battery near end warning or not. ●ON/OFF When set to ON, the the flashing alarm and tally lamps can be stopped by pressing the DISP/MODE CHK button.

CARD FUNCTION (SD memory card setting) screen

Item	Description of settings (Items in bold are factory settings.)
SCENE FILE CAM	Reads/writes a scene file from/onto the SD memory card. <ul style="list-style-type: none"> ●READ: Loads the selected scene file (1 to 4) values from an SD memory card. ●WRITE: Saves the current scene file (1 to 4) settings to the SD memory card. ●TITLE RELOAD: Reloads title list.
USER FILE CAM	Reads/writes user files (files other than scene files) from/onto the SD memory card. <ul style="list-style-type: none"> ●READ: Reads the user file settings (1 to 4) stored on the SD memory card. ●WRITE: Saves the current user file settings (1 to 4) to the SD memory card. ●TITLE RELOAD: Reloads title list.
SD CARD FORMAT CAM	Formats the SD memory cards or not. <ul style="list-style-type: none"> ●----: Does not format. ●YES: Format.

LENS SETUP screen

Item	Description of settings (Items in bold are factory settings.)
SHADING SELECT CAM	Selects one of the following shading compensation parameters. <ul style="list-style-type: none"> ●DEFAULT: Standard lens setting ●USER1: User setting 1 ●USER2: User setting 2 ●USER3: User setting 3 ●OFF: Sets shading compensation to OFF.
SHADING (USER) CAM	Selects whether to set shading parameters to SHADING SELECT USER1, 2, and 3 or not. <ul style="list-style-type: none"> ●----: Off ●YES: On This item is disabled when SHADING SELECT is set to DEFAULT or OFF.
CAC PROPERTY CAM	Displays currently used CAC file number and content of CAC file currently loaded in the camera. <ul style="list-style-type: none"> ●----: Off ●YES: On
CAC CARD READ CAM	Selects whether to load CAC file from the SD memory card or not. <ul style="list-style-type: none"> ●----: Off ●YES: On
CAC FILE DELETE CAM	Selects whether to display a list of CAC file loaded in the camera and to delete the selected CAC file. <ul style="list-style-type: none"> ●----: Off ●YES: On
CAC FILE INIT CAM	Returns the CAC file loaded in the camera to its factory default setting. <ul style="list-style-type: none"> ●----: Off ●YES: On
IRIS ADJUST CAM	Forcibly sets the iris. <ul style="list-style-type: none"> ●OFF/F2.8/F16

OTHER FUNCTIONS screen

Item	Description of settings (Items in bold are factory settings.)
USER FILE CAM/MCR	Saves users files on, loads users files from the storage area of the camera (EEPROM), and initializes the storage area. ●----: Off (no operation) ●LOAD: Loads the settings in a user file previously stored on the storage area. ●SAVE: Saves the user file updated settings on the storage area. ●INITIAL: Returns the user settings in the user file to their factory defaults. • After a LOAD or INITIAL operation, turn the POWER switch off and then back on again to make the new settings available. • An INITIAL operation does not change the setting of the menu option TIME ZONE.
1394CONTROL CAM	Sets the control method for backup recording using a backup unit connected to the 1394 terminal. ●OFF: The backup unit is not controlled. ●EXT: The backup unit can be controlled by the START/STOP button. The images shot by the camera recorder are recorded by the backup unit. Note that the camera recorder does not record them. ●BOTH: The images shot by the camera recorder are recorded by both the camera recorder and backup unit. ●CHAIN: When the camera recorder's media approaches its end during shooting, the backup unit in the recording standby mode automatically starts recording images. When set to BOTH, direct shooting (function that automatically engages the CAMERA mode and starts shooting when pressing the START/STOP button in the MCR mode) starts camera recording but does not set a backup device to recording mode.
1394CMD SEL CAM	Sets how the REC START/STOP button works for the backup unit. ●REC_P: This switches between recording and pause. ●STOP: This switches between recording and stop. If the backup unit does not have a rec pause function, select STOP.
PC MODE CAM/MCR	Selects the terminal for data transfer. (You cannot select USB and 1394 at the same time.) ●USB DEVICE: Mode for sending files using the USB connector. ●1394 DEVICE: Mode for sending files using the 1394 connector. ●1394 HOST: Mode for copying files from the P2 card onto an external hard disk drive using the 1394 connector.
ACCESS LED CAM/MCR	Enables or disables the access LED. The L-SIDE is the P2 card slot side. (ON: LEDs turn on and blink normally. OFF: LEDs always stay off.) ●OFF L-SIDE: OFF R-SIDE: OFF ●SLOT SIDE L-SIDE: ON R-SIDE: OFF ●LCD SIDE L-SIDE: OFF R-SIDE: ON ●BOTH L-SIDE: ON R-SIDE: ON
ALARM CAM	Turns the alarm function on and off. ●ON, OFF
SAVE LED CAM/MCR	Sets the SAVE lamp operation. ●SAVE: Lights when the SAVE/STBY switch is set to SAVE. ●P2CARD: Blinks when a warning message appears to indicate that there is little space left on a P2 card.
CLOCK SET CAM/MCR	Sets the camera-recorder's calendar. ●----: Does not set ●YES: Sets
TIME ZONE CAM/MCR	Adds to or deducts from GMT the time value of -12:00 to +13:00 in 30-minute steps. (As an exception, you can set +12:45.) ●0:00
LANGUAGE CAM/MCR	Sets the Menu language. ●ENGLISH ●JAPANESE ●CHINESE
GL SELECT CAM	Determines which signal to lock on to. ●SDI, COMPOSITE
GL PHASE CAM	Determines whether to perform a 90H shift (ON) or not (OFF). ●ON, OFF
H PHASE CAM	Adjusts the phase. ●-512 ~ 0 ~ +511
SYSTEM FREQ CAM/MCR	Switches the system frequency. ●59.94 Hz, 50 Hz (AG-HPX500P) ●59.94 Hz, 50 Hz (AG-HPX500E)

OPTION MENU screen

This screen is displayed when you press the front MENU button after displaying the shooting status by pressing and holding down the DISP/MODE CHK button. Use this screen to confirm the connection status during nonlinear editing.

Item	Description of settings
1394 STATUS CAM/MCR	The 1394 status sub-screen is displayed. ● FORMAT: format of the signal being input or output ● RATE: transfer rate of the signal being input or output ● 60/50: system of the signal being input or output ● CH: channel number being input or output ● SPEED: transfer speed of the signal being input or output ● STATUS: status of the signal being input or output via the IEEE 1394 digital interface ● VIDEO: status of the video signal being input or output ● AUDIO: status of the audio signal being input or output
1394 CONFIG CAM/MCR	The 1394 expanded menu is displayed. ● DFLT: Normally use the menu as displayed. 1-255

Connecting to External Devices Using USB2.0 Port (PC mode)

By connecting the AG-HPX500P/E with an external PC using USB 2.0, the P2 card connected to the AG-HPX500P/E can be used as a mass storage device.

Procedures for establishing a connection with a PC

1 Connect the USB cable to the USB 2.0 port.

<Notes>

- The USB 2.0 cable is not included with AG-HPX500P/E. Please use a commercially available USB 2.0 cable (shield with a ferrite core).
- The camera supports USB cable lengths up to 5 meters. However, we recommend using a USB cable shorter than 3 meters.

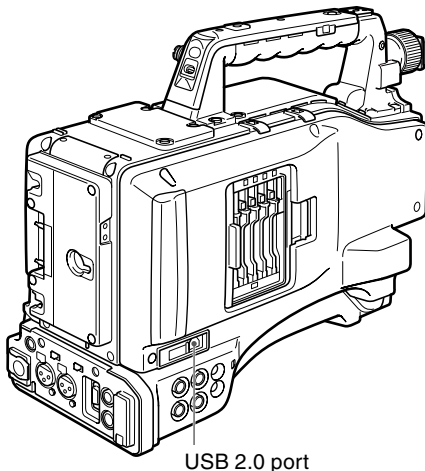

2 Open the setting menu <OTHER FUNCTIONS> screen, and set the menu option PC MODE to USB DEVICE.

For details on menu operation, refer to [Using the menus] (page 116).

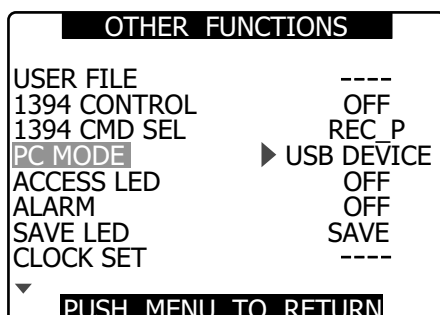

3 Press the MENU button to end menu operations.

4 Press the MODE button to turn on the MCR mode LED and keep the button held down.

- This lights the PC mode LED indicating that the unit is in the PC mode.

5 Edit data on the PC.

- For details, refer to the Operating Instructions supplied with the PC.

When you establish the USB connection for the first time, install the accessory P2 software for AG-HPX500P/E on the PC. Select AG-HPX500 for the USB driver during installation.

Refer to the Installation Manual for the details.

<Notes>

- A USB driver must be installed on the PC.
- The camera is only compatible with USB 2.0. Use a PC that supports USB 2.0.
- Only one AG-HPX500P/E at a time must be connected to the PC via USB.
- The P2 card must not be removed when it is connected via USB.
- While a USB connection is established, the P2 card's access LED should not be lit except when access is being carried out.
- Recording, playback and clip thumbnail operations cannot be performed when the PC MODE is set to USB DEVICE.
- Be sure to follow "Safe hardware removal" procedures on the PC when disconnecting the USB cable.
- "CONNECT" lights during USB connection. "USB DEVICE" appears at the center of the viewfinder.
- "DISCONNECT" appears when the devices are not correctly connected.

6 To exit the PC MODE, turn the POWER switch OFF.

Connecting to External Devices Using the IEEE1394 Connector (PC mode)

Connecting an external PC or hard disk to this unit via IEEE1394 makes it possible to use the P2 cards in this unit as mass storage.

Procedures for establishing a connection with a PC

1 Connect the IEEE1394 cable to the 1394 connector.

<Note>

- An IEEE1394 cable is not supplied. Purchase a commercially available cable.
- Use a Macintosh computer running Apple® Mac OS® X in version 10.3 or later.
- This operation is not guaranteed under Windows®.
- Pay attention to cable connector orientation during connection.

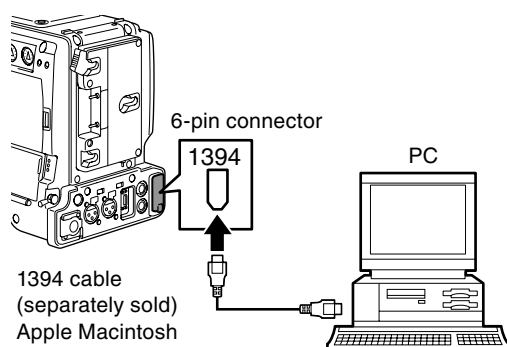

2 Open the setting menu <OTHER FUNCTIONS> screen and set the menu option PC MODE to 1394DEVICE.

For details on menu operation, refer to [Using the menus] (page 116).

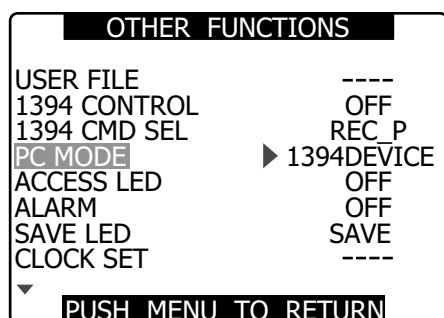

3 Press the MENU button to end menu operations.

4 Press the MODE button to turn on the MCR mode LED and keep the button held down.

- This lights the PC mode LED indicating that the unit is in the PC mode.

5 Edit data on the PC.

- For details, refer to the Operating Instructions supplied with the PC.

<Note>

- Do not remove P2 cards when using an IEEE1394 connection.
- Place the driver icon in the trash before replacing a card.
- Place all driver icons in the trash and check that the 1394DEVICE-DISCONNECT message appears before disconnecting the 1394 cable.
- Recording, playback and clip thumbnail operations cannot be performed when the PC MODE is set to 1394DEVICE.
- PC data cannot be saved on a P2 card.

When the unit is connected to an IEEE1394 device, "1394DEVICE CONNECT" is displayed at the center of the viewfinder. "DISCONNECT" appears when the devices are not correctly connected.

6 To exit the PC mode, turn the POWER switch OFF.

Procedures for connecting a hard disk

<Note>

- Use a hard disk with sufficient space for copying.
- Format the hard disk for this unit. Note that this deletes all existing data on the hard disk.
- Connect this unit to a hard disk with a 1394 cable.
- Even if the hard disk is turned off, be sure to make only one connection. There must be no multiple connections (chaining, hub connections, etc.).

1 Turn on the hard disk (1394.a SBP2 compliant), connect the IEEE1394 cable, and then turn on this unit.

2 Open the setting menu **OTHER FUNCTIONS** screen and set the menu option **PC MODE** to **1394HOST**.

For details on menu operation, refer to [Using the menus] (page 116).

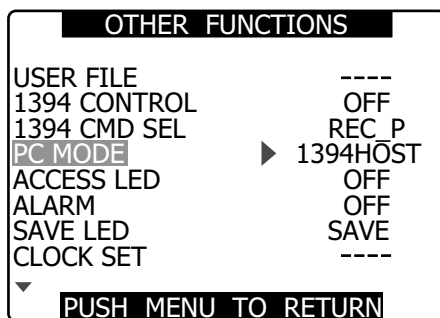

3 Press the **MENU** button to end menu operations.

4 Press the **MODE** button to turn on the **MCR mode LED** and keep the button held down.

- This lights the PC mode LED indicating that the unit is in the PC mode.

5 If the hard disk has not been formatted, use the cursor buttons to select **FORMAT (HDD)** and press the **SET** button.

- Then use the JOG dial button to select YES and press the SET button.
- Formatting starts. (Formatting takes about 2 or 3 seconds.)

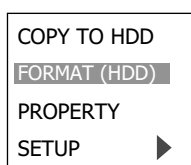

6 When formatting ends, use the cursor buttons to select **COPY TO HDD** and press the **SET** button.

- The data is copied to the hard disk in card units.



7 Use the cursor buttons to select a card slot and press the **SET** button.

- Then use the cursor buttons to select YES and press the SET button to start copying.
- Up to 15 copy operations can be made to one hard disk.

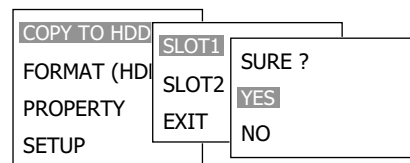

8 Turn the **POWER** switch off when copying completes.

To check data copied to hard disk

After completing step 4, use the cursor buttons to select **PROPERTY** and press the **SET** button to view hard disk data.

- To view details, use the cursor buttons to select an item and press the SET button.

To verify data copied to a hard disk

After completing step 4, use the cursor buttons to select YES for VERIFY in SETUP.

- Data copied from a P2 card will not be affected even if processing should be interrupted during verification.

<Note>

- Data cannot be copied from the hard disk to a P2 card.
- Use hard disks under the following conditions.
 - Use a separate power supply (not the 1394 bus) to power the hard disk since this unit cannot supply power.
 - Format the hard disk for this unit.
 - Operate hard disks within its operating specifications (temperature, etc.).
 - Do not use hard disks in locations that are unstable or exposed to vibration.
- Some hard disks may not operate normally.
- During formatting and copying, do not disconnect cables, do not remove a P2 card that is involved in any of these activities and do not power off this unit and the hard disk. Any of these operations will require turning once off the camera and the hard disk, and then turning them on again.
- If you first set PC MODE to 1394HOST before connecting a hard disk (1394.a SBP2 compliant), normal operation is not guaranteed. Turn the power off and exit the 1394HOST mode.
- A hard disk is a precision instrument whose read and write functions may fail in some operating environments. Please note that Panasonic accepts no liability whatsoever for data loss or other losses either direct or indirect arising from hard disk damage or other defects.
- When the hard disk used to copy data from this unit is replaced with another device (PC, etc.), the data may no longer work in this unit and the hard disk data may have become corrupted.
- It is recommended that you repair bad clips on a P2 card before copying them.
- Use a stable power supply to ensure that copying, formatting and other operations are not interrupted.

Warnings

- **HDD CAPACITY FULL!**
There is not enough space left on the hard disk.
- **TOO MANY PARTITIONS!**
There are too many partitions.
- **HDD DISCONNECTED!**
The hard disk is disconnected.
- **CANNOT INITIALIZE!**
The hard disk cannot be initialized.
- **TOO MANY TARGETS!**
There are too many 1394 connections.
- **CANNOT ACCESS TARGET!**
The connected device cannot be accessed.
- **CANNOT ACCESS CARD!**
The card cannot be accessed.
- **MISMATCH COMPONENT!**
There is a mismatch with the connected device.
- **UNKNOWN DEVICE CONNECTED!**
A device other than a hard disk is connected.
- **P2 CARD IS UNFORMATTED!**
The P2 card has not been formatted.
- **CARD IS EMPTY! CANNOT COPY!**
There is no data on the P2 card to copy.
- **VERIFICATION FAILED!**
Verification turned up a mismatch.
- **TURN POWER OFF!**
Turn off the power.
- **CANNOT RECOGNIZE HDD!**
Hard disk recognition failed.

DVCPRO/DV Connection via IEEE1394 Connector

Recording DVCPRO/DV signals input to 1394 connector

1 Connect a 1394 cable.

For details, see [Precautions in 1394 Connections] (page 136).

- Make sure that the signal format of the camera and the connected device is the same.

2 To input via the IEEE1394 interface, enter MCR mode and turn off thumbnails.

<Note>

- Input signals that have the same format as the setting menu MCR FORMAT and 480i (576i) MCR MODE to the IEEE1394 interface. A signal in a different format will not be correctly recorded on a P2 card. Video and audio recording and EE type video and audio of signal inputs other than 1x speed playback signals may not work.

For details, see [Errors] (page 72).

- Audio signal inputs are input signals from the 1394 connector.
- 32 kHz/4CH (12 bit) audio signals input via the IEEE1394 interface are recorded as 48 kHz/4CH (16 bit) on a P2 card.
- It is not possible to use the GENLOCK IN connector to synchronize to an external reference signal.
- Signals output from the VIDEO OUT or AUDIO OUT connectors differ from actual input signals. Use such signals for monitoring.
- The following functions do not operate.
 - Pre-recording function
 - Loop recording function
 - Interval recording and one shot recording function
- Inputs via the 1394 interface are not available when 720P/24PN, 30PN or 25PN are selected in the setting menu MCR FORMAT.

Time Code and User Bits

- When input from the IEEE1394 interface is selected, the time code or user bits input to the TC IN connector cannot be recorded on a P2 card.
- When input from the IEEE1394 interface is selected, time code output from the TC OUT connector is not synchronized to the video signal output from the VIDEO OUT connector.

Subcode area time codes and user bits

- When input from the IEEE1394 interface is selected, or the TCG switch is set to F-RUN and the menu option F-RUN TC SLAVE in the RECORDING SETUP screen is set to 1394, the time code of the subcode area input from the 1394 connector can be recorded on a P2 card.
- To record user bits input from the 1394 connector on a P2 card, set the setting menu 1394 UB REGEN in the RECORDING SETUP screen to ON.

VAUX area time codes and user bits

When input from the IEEE1394 interface is selected, time code and user bits of the VAUX area input from the 1394 connector is recorded on a P2 card regardless of camera menu settings and switch positions.

Recording UMID (Unique Material Identifier) data

When input from the IEEE1394 interface is selected, UMID data input via the 1394 connector is recorded on a P2 card. When no UMID data is available, the camera generates and records such data. UMID data is not recorded when the camera is operating in the DV mode.

Control of external devices through 1394 connection

Using the 1394 interface to connect an external device for backup recording allows the operator to control start and stop operation of backup recording from the camera.

1 Connect a 1394 cable (DV cable).

For details, see [Precautions in 1394 Connections] (page 136).

- Set 1394 CONTROL in the setting menu OTHER FUNCTIONS screen to BOTH.

2 Use the setting menu 1394 CMD SEL (OTHER FUNCTIONS) to select the command for terminating recording that external devices receive.

For details on menu operation, refer to [Using the menus] (page 116).

<Note>

- When the camera is set to REC RUN to perform backup recording on a connected external device, the advance of time code from the 1394 connector will stop when all P2 cards have been fully recorded regardless of whether backup recording continues.
- It may not be possible for an external device to back up recording when quick transitions are made between recording and stopping.

- Unprocessed video and audio signals are output via the IEEE 1394 interface during special playback. When monitored on another device, these video and audio signals may sound different than when played back on this unit.
- CH1 and CH2 audio channel signals for the DV or DVCPRO (25M) format are output via the IEEE1394 interface.

Precautions in 1394 Connections

- The camera does not supply power via the cable.
- Observe the following in connections using a 1394 cable.
 - Connect this unit to only one other device.
 - Do not expose the 1394 connector to excessive force when connecting a 1394 cable to avoid damaging the connector.
 - If an error (1394 INITIAL ERROR) should occur when making a connection, reinsert the 1394 cable or turn the camera off and then turn it back on again.
 - Make sure that the camera and all connected devices are connected to ground (or connected to a common ground). If the equipment cannot be connected to ground, turn off all connected devices before connecting or disconnecting an IEEE 1394 cable.
 - When connecting the unit to a device with a 4-pin connector, connect the cable to the 6-pin connector on the camera first.
 - Be sure to properly connect the 1394 cable to a personal computer with a 6-pin connector. Note that inserting the plug the wrong way round may damage the connector.

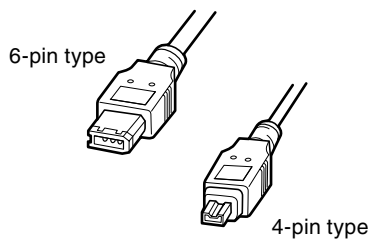

- AV signals may be disrupted when connected devices are turned on and off or when the interface cable is connected or disconnected.
- It may take the system a few seconds to stabilize after switching input signals or changing modes. Start recording after the system has stabilized.
- The AUDIO LEVEL control does not work in recordings that involve IEEE1394 interface input or output signals.
- Observe the following precautions when controlling a P2 memory card camera-recorder using PC application software (editing software).
 - Recording cannot be inserted to a portion within a clip. It can only be appended to the end of the newest clip.
 - Do not open the thumbnail screen during application software operation as this may prevent normal software operation.

Inspections Before Shooting

Make sure you check that the system is operating normally before embarking on a shoot. We recommend using a colour video monitor to check the image.

Preparing for Inspections

- 1 Mount a charged battery pack.
- 2 Turn the POWER switch to ON to check the battery remaining level in the viewfinder.
 - When battery capacity is low, replace it with a fully charged battery.

TEXT MEMO	
23 : 59 : 59	
T	13.5V
9 9	

3 Insert a P2 card into the card slot and close the slide cover.

- Confirm that the P2 card access LED for the inserted card slot lights up in orange. If P2 cards are inserted into multiple card slots, only the P2 card access LED for the first-inserted (first-accessed) P2 card lights up in orange. Then, the other P2 card access LEDs light up in green when P2 cards are inserted.
- If the access LED for the P2 card slot in which a P2 card is inserted keeps blinking in green, or if there is no display, recording is not possible on that particular P2 card.

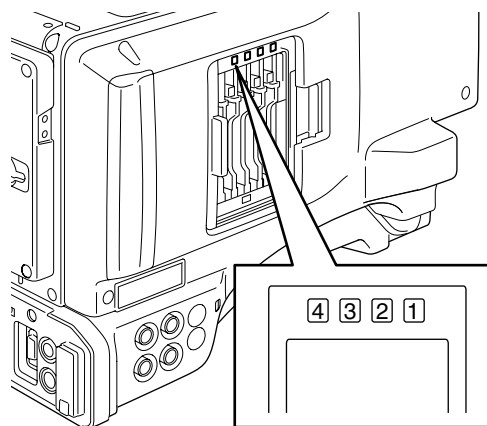

Inspecting the Camera Unit

- 1** Set the zoom to electric zoom mode and check the zoom operation.
 - Check that the image changes to telephoto and wide angle.
- 2** Set the zoom to manual zoom mode and check the zoom operation.
 - Turn the manual zoom lever to check that the image changes to telephoto and wide angle.
- 3** Set the iris to automatic adjustment mode and aim the lens at objects with different degrees of brightness, to check that the automatic iris adjustment operates normally.
- 4** Set the iris to manual adjustment mode and turn the iris ring, to check the manual iris adjustment.
- 5** While holding down the instant iris automatic adjustment button, aim the lens at objects with different degrees of brightness, to check that the instant iris automatic adjustment operates properly.
- 6** Return the iris to automatic adjustment mode and change the GAIN switch setting to L, M, and H, to check the following items:
 - The iris is adjusted for objects with the same brightness according to the switch setting.
 - The gain value displayed on the viewfinder screen changes according to the switch setting.
- 7** When a lens with an extender is mounted, set the extender to the operating position to check that the extender operates properly.

Inspecting the Memory Recording Functions

Make sure you successively carry out the inspections from [Inspecting the P2 Card Recording] (page 138) to [Inspecting the Earphone and Speaker] (page 139).

Inspecting the P2 Card Recording

- 1** Check on the display inside the viewfinder that the remaining P2 card recording capacity is sufficient.

Please refer to [P2 Card Status Display] (page 113) for information about P2 card remaining recording capacity.
- 2** Set the TCG switch to [R-RUN].
- 3** Set the COUNTER button to TC.
- 4** Press the camera's REC START/STOP button to check the following items:
 - The P2 access LED blinks in orange.
 - The REC lamp inside the viewfinder lights up.
 - System warnings do not appear inside the viewfinder.
- 5** Press the camera's REC START/STOP button again.
 - This step confirms that the P2 access LED is on and showing orange, and the REC lamp in the viewfinder is turned off.
- 6** Using the REC START/STOP button on the handle, repeat Steps 4 to 5 to check the same operation.
 - Check the VTR button on the lens in the same way.
- 7** Engage the MCR mode and select the recorded clip from the thumbnail to play it back.
 - Check that recording and playback operate properly.

- 8** Use the **USER** button to which the **SLOT SEL** function has been assigned to select **P2** cards for recording when more than one **P2** card is inserted in the card slots.

- Repeat the operations in Steps 4 to 5 and 7 to check that recording and playback operate properly.

Inspecting the Audio Level Automatic Adjustment

- 1** Set the **AUDIO SELECT CH1** and **CH2** switches to **[AUTO]**.
- 2** Set the **AUDIO IN** switch to **[FRONT]**.
- 3** Aim the microphone connected to the **MIC IN** jack at an appropriate sound source. Then, check that the level displays for both **CH1** and **CH2** change according to the sound level.

Inspecting the Audio Level Manual Adjustment

- 1** Set the **AUDIO IN** switch to **[FRONT]**.
- 2** Set the **AUDIO SELECT CH1** and **CH2** switches to **[MAN]**.
- 3** Turn the **AUDIO LEVEL CH1** and **CH2** controls.
 - Check that the level display increases when the controls are turned to the right.
- 4** Set the **AUTO LEVEL CH3** and **AUTO LEVEL CH4** in the setting menu **AUDIO SETUP** screen to **OFF**.
For details on menu operation, refer to [Using the menus] (page 116).
- 5** Set the **MONITOR SELECT** switch to **CH3/CH4** and turn the **AUDIO LEVEL CH3/CH4** controls clockwise to check that the level indication increases.

Inspecting the Earphone and Speaker

- 1** Turn the **MONITOR** control to check that the speaker volume changes.
- 2** Connect an earphone to the **PHONES** jack.
 - Check that the speaker is turned off and the microphone sound can be heard from the earphone.
- 3** Turn the **MONITOR** control to check that the earphone volume changes.

Inspection for Using an External Microphone

- 1** Connect an external microphone to the **REAR 1** and **REAR 2** connectors.
- 2** Set the **AUDIO IN** switch to **[REAR]**.
- 3** Set the **LINE/MIC/+48V** selector switches on the rear panel to **[MIC]** or **[+48V]**, depending on the power supply type of the external microphone.
 - **MIC**: For a microphone with internal power supply.
 - **+48V**: For a microphone with external power supply.
- 4** Aim the microphone at the sound source and check that the sound level indication in the **LCD** or viewfinder varies with changes in sound intensity.
 - The channels can also be checked separately by connecting a single microphone to each channel.

Inspection of the clock, time code, and user bits

- 1 Set the user bits as required.**
Please refer to [Setting the User Bits] (page 60) for the setting procedures.
- 2 Set the time code.**
Please refer to [Setting the Time Code] (page 62) for the setting procedures.
- 3 Set the TCG switch to [R-RUN].**

 - Press the COUNTER button to display the time code on the LCD monitor or in the viewfinder.
- 4 Press the REC START/STOP button.**

 - Check that the counter display number changes as recording progresses.
- 5 Press the REC START/STOP button again.**

 - Check that recording stops and the counter display number stops changing.
- 6 Set the TCG switch to [F-RUN].**

 - Check that the counter display number changes regardless of recording status.
- 7 Hold down the DISP/MODE CHK button to check the date and time on the LCD monitor or in the viewfinder.**

 - Adjust the date and time setting if the DATE, TIME and time zone is not correctly displayed. For details, see [Setting Date and Time of Internal Clock] (page 28).

<Note>
Note that date and time data set for DATE, TIME, and time zone is recorded in clips, and affects the playback sequence, etc. at the time of thumbnail manipulations.

Maintenance

Cleaning Inside the Viewfinder

- Do not use thinner or other solvents to remove dirt from the viewfinder.
- Wipe the lens with a commercially available lens cleaner.
- DO NOT wipe the mirror. If dirt or rubbish is sticking on the mirror, remove it with a commercially available air blower.

Eyepiece Care

When the CRT screen and the mirror become dusty, open the eyepiece to clean it.

<Note>

The mirror is provided with a special coating. Use a blower or similar tool to remove dust from the mirror. Using tissue paper will cause dust particles to scrape against and damage the mirror surface. Use a commercially available hair-planted cloth (such as a lens cleaner) to remove more stubborn dirt.

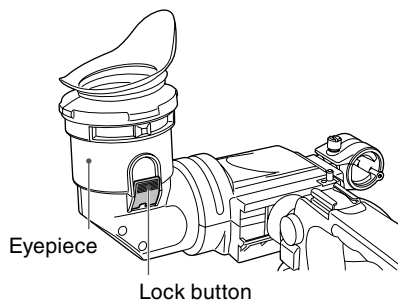

Opening the eyepiece

Press the lock button.

Closing the eyepiece

Press the eyepiece until the lock button clicks into place to close the eyepiece.

<Note>

When outdoors, never carry or set up the camera with the eyepiece facing up to prevent sunlight, which could damage the internal parts of the eyepiece.

Phenomenon Inherent to CCD Cameras

Smears

- Smears may appear when shooting an object with very high brightness.
- This phenomenon may appear more frequently as the electronic shutter speed increases.

Charging the internal battery

The internal battery preserves the date and time settings. The appearance of  in the viewfinder or LCD monitor indicates that the internal battery is exhausted.

Follow the steps below to recharge the battery. Set the date and time when the battery has been fully charged.

- 1 Connect the camera to an external power source.**
 - Leave the POWER switch on the camera off.
- 2 Leave the camera for about 4 hours.**
 - This is the time it takes to fully charge the internal battery.
 - Check the time code and setting menus after completing battery charging.

Replace the internal battery if  appears after charging. Consult your distributor.

Warning System

Warning Description Tables

If a problem is detected immediately after the power is turned on, or during operation, this will be indicated by the WARNING lamp, lamps inside the viewfinder and a warning tone.

Priority	Warning type	LCD or viewfinder indication	Viewfinder LED (except tally)	Tally lamp	Warning lamp	Alarm tone *6	Warning description and recording/playback operation	Countermeasures
1	System error	SYSTEM ERROR Cause indication *1 Red blinking	No	Blinks 4 times per second	Blinks 4 times per second	Continuous tone	P2 microprocessor or control failure. Operation stops.	Check the cause indication *1 and consult your distributor.
2	Incorrect P2 card removal	TURN POWER OFF Blinks red	No	Blinks 4 times per second	Blinks 4 times per second	Continuous tone	A P2 card was removed during access and card data was corrupted. All four access LEDs blink orange (4 Hz)	Turn off the power. Repair the P2 card if the clips on the card are corrupted.
3	The battery is exhausted	LOW BATTERY Red blinking, and the battery level bar blinks with the empty status. (This indication appears also when MENU indications have been turned OFF.)	No	Blinks 1 time per second	Lights	Continuous tone	The battery is exhausted. Recording and playback stop. The camera stops automatically when the voltage drops.	Replace the battery.
4	P2 card fully recorded	 FULL Blinks red (appears only for 3 seconds in MCR mode.)	When SAVE LED is set to P2CARD, the SAVE LED blinks 4 times per second.	Blinks 4 times per second after completion of recording.	Lights after completing recording	Continuous tone after completing recording	No more space on P2 cards left for recording. Stop recording. *3	Delete clips that are no longer needed or insert a new card.
5	Recording error	REC WARNING Cause indication *2 Blinks red	No	Blinks 4 times per second	Blinks 4 times per second	Intermittent tone 4 times per second	A recording error has occurred. Stop recording. *4	Turn the power off and then back on again and check recording and playback. Replace any P2 card that does not enable normal recording.
6	1394 connection errors	1394INITIAL ERROR Blinks red	No	Blinks 4 times per second during recording.	Blinks 4 times per second during recording.	No	Incorrect 1394 connection or signal input/output error.	Check camera and external device connections and reconnect as necessary. Then turn the power off and back on again.
7	PC mode 1394 HOST connection error	No	No	Blinks 4 times per second	Blinks 4 times per second	No	The 1394 cable has become disconnected or multiple devices are connected. (Normal PC mode operation is possible.)	Connect a hard disk drive according to supplied operating instructions.

Priority	Warning type	LCD or viewfinder indication	Viewfinder LED (except tally)	Tally lamp	Warning lamp	Alarm tone * ⁶	Warning description and recording/playback operation	Countermeasures
8	Battery nearly empty	The last bar in the battery level indication blinks (This indication appears also when MENU indications have been turned OFF.)	The BATT LED blinks (during recording, the BATT LED and the tally LED blink alternately; during pause, both LEDs blink.)	Blinks 1 time per second	Blinks 1 time per second	No	The battery is near depletion. Operation continues. * ⁵	Replace the battery as necessary.
9	P2 card nearly fully recorded	The P2CARD level indicator blinks.	When SAVE LED is set to P2CARD, the SAVE LED blinks 1 time per second.	Blinks 1 time per second during recording.	Blinks 1 time per second during recording.	No	Less than 2 minutes is left on the P2 cards (level indicator shows 1 minute or less). This warning appears only during recording.	Replace or insert additional P2 cards.

*¹ P2 SYSTEM ERROR cause indication

- P2 MICON ERROR: The P2 microprocessor does not respond
- P2 CONTROL ERROR: A P2 recording error has occurred
- REC RAM OVERFLOW: Overflow of recording RAM

*² REC WARNING causes

- CARD ERROR*: P2CARD error (* indicates the number of the slot of the card with the error)
- ERROR: Other recording errors

*³ In a transition from thumbnail display to recording, a further transition is made to CAMERA mode where a warning is output. Perform either of the following procedures to cancel this warning.

- Press a playback control button.
- Press the MODE (CAMERA/MCR/PC) button.
- Remove the P2 card and insert another card.

*⁴ Perform either of the following procedures to cancel this warning.

- Press the REC START/STOP button.
- Press a playback control button.
- Press the MODE (CAMERA/MCR/PC) button.
- Remove all cards.

*⁵ When NEAR END CANCEL is set to ON, you can press the DISP/MODE CHK button to cancel the alarm.

*⁶ When the alarm sounds, audio is not output to the camera speakers or headphones. The DISP/MODE CHK button cancels only the alarm tone when pressed during an alarm.

Updating Camera Drivers

- For the latest information on software drivers, visit the P2 Support Desk at the following Web sites.
<http://pro-av.panasonic.net/>
- Before updating the camera driver, check camera driver version in the PROPERTY → SYSTEM INFO in the thumbnail menu. Then access the site listed above to download a driver if necessary.
- Place the downloaded file on an SD memory card and load the driver into the camera. For detailed information on the update procedure, visit the above site.
 - The camera driver may not install properly if the power supply is not constant during installation. Be sure to provide a steady power supply throughout installation by using an external DC power supply, for example.
 - The camera uses only SD memory cards that comply with the SD specifications.
- Be sure to format SD memory cards in this camera. To format an SD card on a PC, use the following software that can be downloaded from the site listed above.

Chapter 10 Specifications

Dimensions and specifications

Dimensions

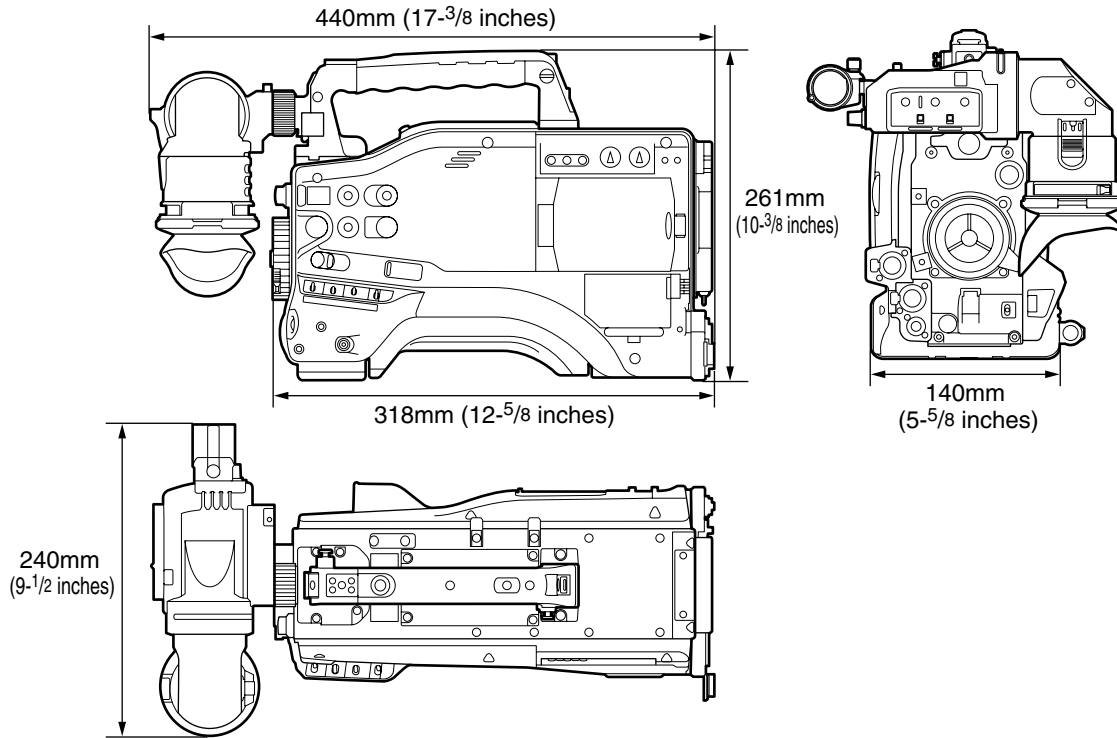

Specifications

General

Power supply:	DC12 V (11 V to 17 V)
Power consumption:	23 W (When 1.5-type CRT of viewfinder and 89 mm (3.5 inch) LCD monitor of main unit are ON) 19 W (without viewfinder, and when LCD monitor is OFF)

 indicates safety information.

Ambient operating temperature/humidity:	0 °C to 40 °C (32 °F to 104 °F)/10% to 85% (no condensation)
Storage temperature:	-20 °C to +60 °C (-4 °F to 140 °F)
Weight:	Approximately 3.8 kg (8.38 lb) (main unit only, excluding the viewfinder mount) Approximately 4.5 kg (9.92 lb) (including 1.5-type CRT of viewfinder)
Dimensions (W × H × D):	140 mm × 261 mm × 318 mm (5 ⁻⁵ / ₈ inches × 10 ⁻³ / ₈ inches × 12 ⁻⁵ / ₈ inches) (camera excluding prominent parts)

Camera Unit

Pickup devices:	CCD image sensor × 3 (2/3-type, interline transfer, progressive-capable)
Lens mount:	2/3-type bayonet
Color separation optical system:	Prism system
ND filter:	4 positions (CLEAR, 1/4, 1/16, 1/64)
Gain settings:	<ul style="list-style-type: none"> • 60i/60P/50i/50P mode: 0/+3/+6/+9/+12/+18 dB • In slow shutter mode: gain fixed at 0 dB • 30P/24P/25P mode: 0/+3/+6/+9/+12 dB • In slow shutter mode: gain fixed at 0 dB
Shutter speed (preset):	<ul style="list-style-type: none"> • 60i/60P mode: 1/60 (OFF), 1/100, 1/120, 1/250, 1/500, 1/1000, 1/2000 sec. • 30P mode: 1/30 (OFF), 1/50, 1/60, 1/120, 1/250, 1/500, 1/1000 sec. • 24P mode: 1/24 (OFF), 1/50, 1/60, 1/120, 1/250, 1/500, 1/1000 sec. • 50i/50P mode: 1/50 (OFF), 1/60, 1/120, 1/250, 1/500, 1/1000, 1/2000 sec. • 25P mode: 1/25 (OFF), 1/50, 1/60, 1/120, 1/250, 1/500, 1/1000 sec.
Shutter speed (Synchro scan):	<ul style="list-style-type: none"> • 60i/60P mode: 1/60.0 to 1/249.8 • 30P mode: 1/30.0 to 1/249.8 • 24P mode: 1/24.0 to 1/249.8 • 50i/50P mode: 1/50.0 to 1/248.9 • 25P mode: 1/25.0 to 1/248.9
Shutter speed (slow):	<ul style="list-style-type: none"> • 60i/60P mode: 1/15, 1/30 • 30P mode: 1/15 • 24P mode: 1/12 (720P only) • 50i/50P mode: 1/12, 1/25 • 25P mode: 1/12
Shutter opening angle:	• 10 degrees to 360 degrees in 0.5-degree increments (when OPERATION TYPE in the SCENE FILE screen is set to FILM CAM).
Frame rates:	<ul style="list-style-type: none"> • 59.94Hz mode: variable 12/18/20/22/24/26/30/32/36/48/60 fps (frames per second) • 50 Hz mode: variable 12/18/20/23/25/27/30/32/37/48/50 fps (frames per second)
Sensitivity:	F10 (Typ, 2000 lx)

Memory Card Recorder Unit

Recording format:	DVCPRO HD / DVCPRO50 / DVCPRO/DV selectable
Recording audio signal:	<ul style="list-style-type: none"> • PCM digital recording, 48 kHz/16-bits • 4 CH (DVCPRO HD/DVCPRO50), 2 CH/4 CH selectable (DVCPRO/DV)
Recording/playback time*:	<ul style="list-style-type: none"> • Approx. 8 minutes (When recorded in DVCPRO HD format using one AJ-P2C008HG card with audio signals recorded on 4 channels) • Approx. 16 minutes (When recorded in DVCPRO HD format using one AJ-P2C016RG card with audio signals recorded on 4 channels)
Recording media:	P2 Card (4GB, 8GB, 16GB are available) × 4 slots
Recording file:	MXF file (FAT32 file system)
SD memory card slot:	<ul style="list-style-type: none"> • Complies with SD format (MMC cannot be used) • 1 slot (for reading and writing camera setup data)

* The recording time represents one shot continuously recorded on a P2 card. The recording time may be shorter depending on the number of shots recorded.

■HD video system

Sampling frequency:	Y: 74.25 MHz, Pb/Pr: 37.125 MHz
Quantizing:	8 bits
Video compression system:	DCT + variable-length code
Video compression rate:	1/6.7
Video recording bit rate:	100 Mbps

■Audio system

Sampling frequency:	48 kHz
Quantizing:	16 bits/4 CH
Head room:	20 dB/18 dB (selectable)

Video Input/Output

GEN LOCK IN:	BNC × 1, 1.0 V p-p, 75 Ω
COMPONENT OUT:	D4 terminal (component), Y: 1.0 V p-p, 75 Ω, Pb/Pr: 0.7 V p-p, 75 Ω
VIDEO OUT:	BNC × 1, 1.0 V p-p, 75 Ω
SDI OUT:	<ul style="list-style-type: none"> • BNC × 1, 0.8 V p-p, 75 Ω • HD: compliant with SMPTE 292M/296M/299M • SD: compliant with SMPTE 259M-C/272M-A/ITU-R.BT656-4

Audio Input/Output

MIC IN:	<ul style="list-style-type: none"> • XLR × 2 (FRONT 1, FRONT 2) • high impedance • + 48 V (available) • MIC: -40 dBu/-50 dBu/-60 dBu (selectable on menu)
AUDIO IN:	<ul style="list-style-type: none"> • XLR × 2 (REAR 1, REAR 2) • high impedance • LINE/MIC / + 48 V (selectable) • LINE: 0 dB • MIC: -50 dBu/-60 dBu (selectable on menu)
AUDIO OUT:	Pin jack × 2 (CH 1, CH 2), Output: 316 mV, 600 Ω
Headphone:	ø3.5 mm stereo mini jack × 1
Internal speaker:	28 mm diameter × 1

Other Input/Output

TC IN:	BNC × 1, 0.5 V p-p to 8 V p-p, 10 kΩ
TC OUT:	BNC × 1, low impedance, 2.0 V p-p ± 0.5 V p-p
IEEE1394:	6 pins, digital input/output (compliant with IEEE 1394)
DC IN:	XLR × 1, 4 pins, DC 12 V (11.0 V to 17.0 V)
DC OUT:	4 pins, DC 12 V (11.0 V to 17.0 V), max. 1.5 A
REMOTE:	10 pins
LENS:	12 pins
EVF:	20 pins
USB2.0 (DEVICE):	Type-B, 4 pins (compliant with USB ver. 2.0)

LCD Monitor

LCD monitor:	89 mm (3.5-inch) LCD color monitor, 210,000 pixels (4:3)
--------------	--

Accessories

Accessories:	<ul style="list-style-type: none">• 1.5-type viewfinder (4:3 CRT, NTSC/PAL switchable)• Shoulder strap• Ferrite core (2)• Front Audio Level control knob (page 101)• Control knob mounting screw• Component video cable• PIN-BNC conversion plugs (3)• CD-ROM• Operating Instructions
--------------	---

Connector signal description

DC IN	
1	GND
2	NC
3	NC
4	+12V

Panasonic Part No. K1AA104H0038
 Manufacturer Part No. HA16RX-4P (SW1)
 (Hirose Electric Co.)

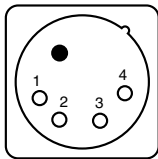

<Note>

Be sure to use correct polarity when using external power supplies.

FRONT MIC IN	
1	GND
2	AUDIO IN (H)
3	AUDIO IN (C)

Panasonic Part No. K1AB103B0013
 Manufacturer Part No. NC3FBH2 (NEUTRIK)

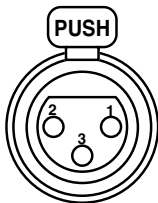

AUDIO IN	
1	GND
2	AUDIO IN (H)
3	AUDIO IN (C)

Panasonic Part No. K1AB103A0007
 Manufacturer Part No. HA16PRM-3SG
 (Hirose Electric Co.)

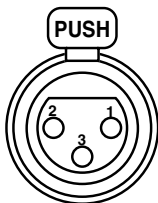

REMOTE	
1	CAM DATA (H)
2	CAM DATA (C)
3	CAM CONT (H)
4	CAM CONT (C)
5	R/C ON
6	R/C VIDEO OUT
7	R/C VIDEO GND
8	NC
9	UNREG 12V (max. 0.6 A)
10	GND

Panasonic Part No. K1AY110JA001
 Manufacturer Part No. HR10A-10R-10SC(71)
 (Hirose Electric Co.)

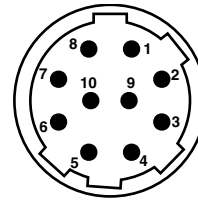

DC OUT	
1	GND
2	NC
3	NC
4	+12V OUT (max. 1.5 A)

Panasonic Part No. K1AY104J0001
 Manufacturer Part No. HR10A-7R-4SC(73)
 (Hirose Electric Co.)

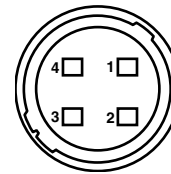

LENS	
1	RET-SW
2	REC-START/STOP
3	GND (ground)
4	IRIS-AUTO
5	IRIS-CONT
6	UNREG +12V (max. 0.4 A)
7	IRIS-POSI
8	IRIS-G-MAX
9	EXT-POSI
10	ZOOM-POSI
11	FOCUS-POSI
12	SPARE

Manufacturer Part No. HR10A-10R-12SC(71)
(Hirose Electric Co.)

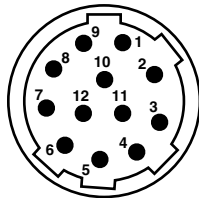

VF	
1	NOREG +12V
2	11 to 17 V approx. 0.2 A for the supplied viewfinder (max. 0.3 A)
3	NC
4	B-Y GND
5	R-Y GND
6	VF VIDEO
7	VIDEO GND
8	VF CLK
9	VF WR
10	VF DATA
11	UNREG GND
12	ZEBRA SW
13	NC
14	NC
15	NC
16	NC
17	NC
18	NC
19	NC
20	Chassis ground

Panasonic Part No. K1AB102H0001
Manufacturer Part No. HR12-14RA-20SC
(Hirose Electric Co.)

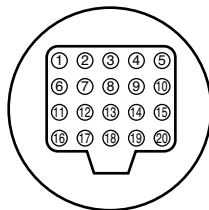

Information for Users on Collection and Disposal of Old Equipment and used Batteries



These symbols on the products, packaging, and/or accompanying documents mean that used electrical and electronic products and batteries should not be mixed with general household waste. For proper treatment, recovery and recycling of old products and used batteries, please take them to applicable collection points, in accordance with your national legislation and the Directives 2002/96/EC and 2006/66/EC.



By disposing of these products and batteries correctly, you will help to save valuable resources and prevent any potential negative effects on human health and the environment which could otherwise arise from inappropriate waste handling.



For more information about collection and recycling of old products and batteries, please contact your local municipality, your waste disposal service or the point of sale where you purchased the items.

Penalties may be applicable for incorrect disposal of this waste, in accordance with national legislation.

For business users in the European Union

If you wish to discard electrical and electronic equipment, please contact your dealer or supplier for further information.



Information on Disposal in other Countries outside the European Union

These symbols are only valid in the European Union. If you wish to discard these items, please contact your local authorities or dealer and ask for the correct method of disposal.

Cd

Note for the battery symbol (bottom two symbol examples):

This symbol might be used in combination with a chemical symbol. In this case it complies with the requirement set by the Directive for the chemical involved.