



2021

CATALOGUE

PRODUCTION. SIMPLIFIED.

NDI[®]



WELCOME TO THE FUTURE.

CAMERAS

Page 4

CONVERTERS

Page 24

SOFTWARE

Page 34

AV SECTION

Page 47

**WELCOME TO THE WORLD OF NDI.
WE'VE BEEN WAITING FOR YOU.**

Hello,

Firstly thank you for your interest in BirdDog and our products. It's truly humbling.

BirdDog is an Australian company started in 2016 with a simple mission – to bring high quality products to market that solve workflow problems and reduce the complexity of equipment required.

At ISE 2020 we are proud to announce NDI Wallplates, which have been designed from the ground up for building into permanent AV installations. Dedicated AV features such as a RESTful API to integrate with control systems such as Crestron as well as EDID, will make for a smooth and seamless end user experience. The interchangeable face plates and soft glow indicators add a level of elegance that will look right at home in high end spaces.

We invest a lot of time listening to our customers to understand their requirements in order to implement features and functions to simplify workflows. BirdDog already has a long list of world first achievements and as we expand our product line we still feel like we are just getting started.

At BirdDog we pride ourselves on being approachable and easily contactable.

We'd love to hear from you.

Dan Miall

Co-Founder and CEO

dan@bird-dog.tv



Eamon Drew

Co-Founder and CMO

eamon@bird-dog.tv



CAMERAS



BirdDog | PF120

Unbox your new NDI® Box Cam.

Introducing PF120, the all new box camera that comes with all the amazing features you have come to expect from BirdDog cameras.

Sony Exmor R back illuminated sensor, Full NDI®, with a 20x optical zoom, and a complete colour matrix all housed in a full metal enclosure that is built for life on the road. You've been asking ever so nicely, so we went ahead and boxed it up for you.

Sony Exmor R Sensor. You deserve the best.

With a Sony Exmor R™ back-illuminated CMOS image sensor, PF120 delivers beautiful images with significantly enhanced imaging characteristics including enhanced low noise sensitivity.

Full NDI®. No compromises.

PF120 features BirdDog's unique NDI silicon to produce visually lossless, full bandwidth NDI, which is a variable bit rate, I-Frame codec that reaches around 140Mbits at 1080p60.

Boss Level Colour Tools.

PF120 has an incredible set of colour tools. With 64 levels of saturation and hue control over red, green, blue, cyan, yellow, and magenta, you can shade and match your PF120 cameras like a total boss. And of course, they're available in Cam Control as well.

USB for Zoom, Teams, Meet. HDMI too.

USB 2.0 UVC output allows for PF120 to connect directly to your favourite video conferencing platform giving even wider flexibility. There's also a HDMI output which is live at the same time as

PoE or locking DC.

PF120 can be powered by Power over Ethernet (PoE 802.11af) or from the included power adapter which has a locking connector for maximum reliability.

20x Zoom & 49mm filter thread.

Adding an ND Filter or even a fisheye lens is now possible with the 49mm filter thread and PF120 also comes with a lens cap.

Built Like a Brick Outhouse.

Custom built from the ground up to withstand the demands of modern productions, PF120 is housed inside a die cast chassis that is as strong as Donkey Kong™. Well almost.

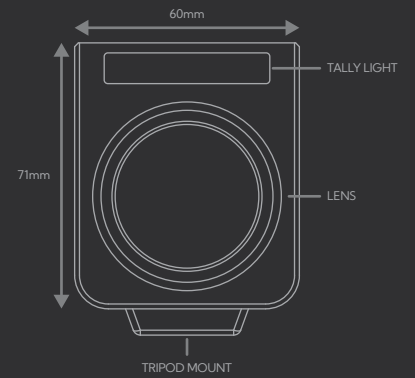
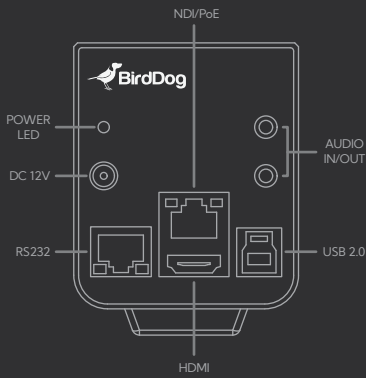

Product Specifications

Camera

Image Sensor: SONY Exmor R CMOS
 1/2.86" - 2.13MP
Lens: 5.2-104mm
Optical Zoom: 20x
Digital Zoom: 16x
Field of View:
 55.8° (W)~3.2° (T)
Aperture: F1.5 (W) – F3.0 (T)
Min. Illumination: 0.5 lux
Shutter Speed: 1/1 – 1/10000s
Filter Ring: Filter 49mm
Focus: Auto, Push, Manual
White Balance: Auto, Indoor, Outdoor, Manual, OPW, ATW
Exposure: Auto, Manual, Shutter/Iris Priority
Backlight Compensation: YES

Mechanical

Tally: Front
Preset Positions: 128
Preset Speed (Zoom): 0-5 Level adjustable
Environmental: Indoor
Operating Temp.: -10 – +50 (°C)
Operating Humidity: ≤80%
Noise at max. movement velocity (Zoom):
 Max 41dB at full speed zoom NC35
Mount: 1/4-20" Tripod mount • 3/8" Tripod mount
Video Interface
Video Output: NDI/HDMI/USB2.0
Video Formats: 1080p 60, 59.94, 50, 29.97, 25
 1080i 60, 59.94, 50 • 720p 60, 59.94, 50
Audio I/O: 3.5mm Audio In (Stereo)
 3.5mm Audio Out (Stereo)
 (NDI, and HDMI only)

Control Interface

IP PTZ Control: NDI Control (auto config.), VISCA
Serial Control Protocol: RS232 VISCA / PELCO D
LAN: RJ45 x1 (1GbE), NDI/IP video streaming, System upgrade, PoE (IEEE 802.11af)
Power & Dimension
Power Input: 12V DC, PoE (IEEE 802.11af)
Max Power draw: 9W
Dimensions: 158x60x71mm
Weight: 666g (1lb 7.4oz)
Network
Video Compression: Full NDI – i-frame high quality low latency NDI for production
 USB UVC protocol
Network Protocol: NDI – Discovery, configuration and control
Web Control interface: Full control via Web/Mobile UI inc. Scene presets



BirdDog | P100

Your entry into the world of NDI®.

Built on BirdDog's custom NDI® silicon chip with a Sony CMOS Sensor, the P100 PTZ camera is your entry into the world of full NDI®. Featuring frame rates up to 1080p60, 10x optical zoom, USB 2.0, HDMI, SDI, and Full NDI® outputs, P100 gives you professional level quality, performance, and total flexibility. 3.5mm audio connectors allow P100 to work with BirdDog Comms, the world's first NDI® audio intercom platform.

Full NDI®.

In the world of NDI® there are two flavours, NDI® and NDIHX. NDI® is a variable bit rate, I-Frame codec that reaches around 140Mbps at 1080p60 and is visually lossless. NDIHX is a compressed, long-GOP, H.264 variant that reaches around 12Mbps at 1080p60. Mini hardware only uses Full YUV422 NDI®.

Sony Sensor.

The best pictures come from the best silicon. P100 is teamed up with a world class Sony CMOS Backlit Sensor with the BirdDog custom NDI® chip to form a match made in silicon heaven. Your productions deserve the best.

NDI®, SDI, HDMI, & USB.

With NDI®, SDI, and HDMI simultaneous outputs the P100 is ready to go live with full NDI® today or can be used as a traditional SDI/HDMI camera. You can rest easy in the knowledge that P100 has you covered for all workflow situations. P100 can connect via USB to use as a webcam. Perfect for boardrooms and huddle rooms.

Tiny Footprint.

P100 is incredibly small with a diameter of just 145mm / 5.7 inches making it perfect for courtrooms, boardrooms, classrooms, and any application where you need a small, yet powerful, PTZ camera.

Extreme Speed. Optics done right.

Lightning auto focus. Insanely fast zoom. Precision optics. P100 has been engineered to meet the most demanding situations whether you are in a boardroom streaming your quarterly results, producing a live event for your church, or live streaming sports.

PTZ Keyboard. Take control.

Combine P100 with the BirdDog PTZ Keyboard and you have total control of all functions remotely. PTZ Keyboard is a full featured controller that can control up to 255 PTZ cameras and can control P100 over NDI® or by RS422 / RS232 when using in SDI mode.



BOLIN

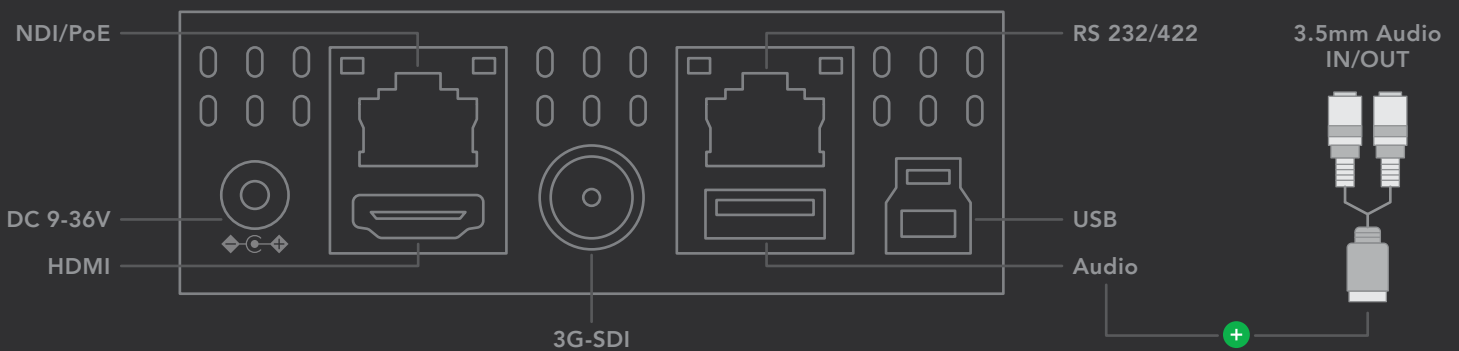

Product Specifications

Camera

Image Sensor: 1/2.86" CMOS 2.2MP
 Lens: 4.7 - 47mm
 Optical Zoom: 10x
 Digital Zoom: 12x
 Horizontal Angle of View:
 60.9° (W) – 6.43° (T)
 Aperture: F1.6 (W) – F3.0 (T)
 Min. Illumination: 0.5 lux
 Shutter Speed: 1/1 – 1/30000s
 Focus: Auto, Push, Manual
 White Balance: Auto, Indoor, Outdoor, Manual, OPW, ATW
 Exposure: Auto, Manual, Shutter/Iris Priority
 Backlight Compensation: YES

Mechanical

Pan Movement: Horizontal: ±175° pan (Zoom Adaptive Speed Range: 0.05° to 100°/s)
 Tilt Movement: Vertical: +90° to -30° (Zoom Adaptive Speed Range: 0.05° to 72°/s)
 Preset Positions: 128
 (Speed adjustable: Up to 150°/s)
 Preset Speed: 0-5 Level adjustable
 Environmental: Indoor
 Operating Temp.: -10 – +50 (°C)
 Operating Humidity: ≤80%

Video Interface

Video Output: NDI/HDMI/3G-SDI/USB 2.0
 Video Formats: 1080p 60, 59.94, 50, 29.97, 25
 1080i 60, 59.94, 50 • 720p 60, 59.94, 50, 29.97, 25
 Limited Resolution support over USB

Audio Interface

(via supplied USB accessory cable)
 Audio I/O: 3.5mm Audio In (Stereo)
 3.5mm Audio Out (Stereo)

Control Interface

IP PTZ Control: NDI Control (auto config.), VISCA IP
 Serial PTZ Control: 1x RJ45: RS232/RS422
 Serial Control Protocol: VISCA / PELCO D

Power & Dimension

Power Input: 12V DC, PoE+ (IEEE 802.3at)
 Dimensions: 145x145x154mm • Weight: 1.0Kg

Network

Video Compression: Full NDI – i-frame high quality low latency NDI for production
 Network Protocol: NDI – Discovery, configuration and control
 Web Control interface: Full control via Web/Mobile UI inc. Scene presets



BirdDog | P200

NDI® has never looked so good.

Designed for serious production the image quality of P200 is best in class. By teaming up BirdDog's custom NDI® silicon chip, a Sony CMOS Backlit Sensor, and a true Sony Image Module, P200 has lightening auto focus, incredibly sharp images, and insanely fast zoom. P200 has frame rates up to 1080p60, 30x optical zoom, and features independent, live triple outputs in SDI, HDMI and Full NDI®.

Full NDI®.

In the world of NDI® there are two flavours, NDI® and NDIHX. NDI® is a variable bit rate, I-Frame codec that reaches around 140Mbps at 1080p60 and is visually lossless. NDIHX is a compressed, long-GOP, H.264 variant that reaches around 12Mbps at 1080p60. P200 is a Full NDI® camera.

NDI®, SDI & HDMI.

With NDI®, SDI, and HDMI simultaneous outputs the P200 is ready to go live with full NDI® today or can be used as a traditional SDI/HDMI camera. You can rest easy in the knowledge that P200 has you covered for all workflow situations.

Sony Sensor.

The best pictures come from the best silicon. P200 teams up a world class Sony CMOS Backlit Sensor with the BirdDog custom NDI® chip to form a match made in silicon heaven. Your productions deserve the best.

Sony Image Module.

Lightning auto focus. Insanely fast zoom. Precision optics. The only way to achieve the best picture quality is with image module made by the world's best. P200 uses a true Sony image module to give unparalleled performance, picture quality, and responsiveness.

30x Optical zoom.

Never miss a shot again. 30x optical zoom brings the whole world to you. Now you can zoom in to the other end of a football game and stay locked in on the action. The incredible optical zoom function makes P200 perfect for sports such as football, baseball, hockey, ski fields, basketball, soccer, and more.

PoE or DC.

P200 can be powered by Power over Ethernet (PoE) or from the included power adapter.



BOLIN

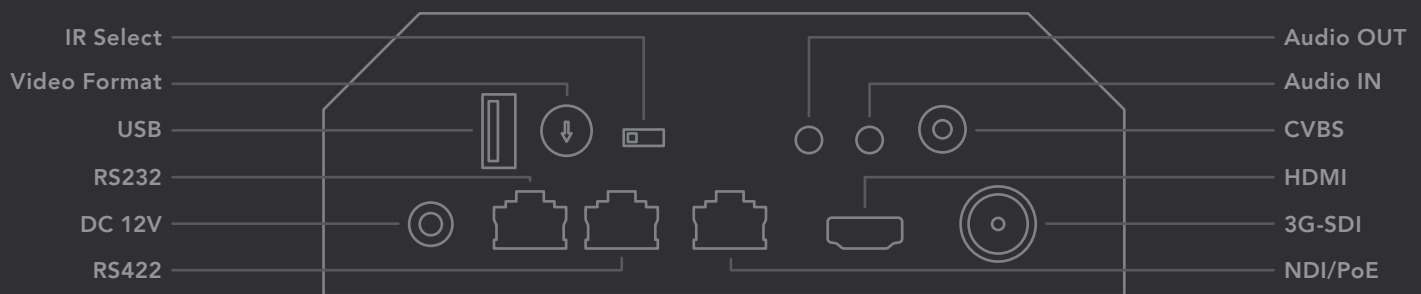

Product Specifications

Camera

Image Sensor: 1/2.8" CMOS 2.13MP
 Lens: 4.3-129mm
 Optical Zoom: 30x
 Horizontal Angle of View:
 63.7° (W) – 2.3° (T)
 Aperture: F1.6 (W) – F4.7 (T)
 Min. Illumination: Color: 0.01 lux (F1.6, AGC on, 1/30s, High sensitive mode), 0.1 lux (F1.6, AGC on, 1/30s, Normal sensitive mode)
 Shutter Speed: 1/1 – 1/10000s
 Focus: Auto, Push, Manual
 White Balance: Auto, Indoor, Outdoor, Manual, OPW, ATW
 Exposure: Auto, Manual, Shutter/Iris Priority
 Backlight Compensation: YES

Mechanical

Pan Movement: Horizontal: ±175° pan (Zoom Adaptive Speed Range: 0.05° to 100°/s)
 Tilt Movement: Vertical: +90° to -30° (Zoom Adaptive Speed Range: 0.05° to 50°/s)
 Preset Positions: 128
 (Speed adjustable: Up to 150°/s)
 Preset Speed: 0-5 Level adjustable
 Environmental: Indoor
 Operating Temperature: -10 – +50 (°C)
 Operating Humidity: ≤80%
Video Interface
 Video Output: NDI/HDMI/3G-SDI
 Video Formats: 1080p 60, 59.94, 50, 29.97, 25
 1080i 60, 59.94, 50 • 720p 60, 59.94, 50
 Audio I/O: 3.5mm Audio In (Stereo)
 3.5mm Audio Out (Stereo)

Control Interface

IP PTZ Control: NDI Control (auto configuring), VISCA IP
 Serial PTZ Control: 2x RJ45:
 RS232 / RS422 / RS485
 Serial Control Protocol: VISCA / PELCO D
Power & Dimensions
 Power Input: 12V DC, PoE+ (IEEE 802.3at)
 Dimensions: 160x178x220mm
 Weight: 2.0Kg
Network
 Video Compression: Full NDI – i-frame high quality low latency NDI for production
 Network Protocol: NDI – Discovery, configuration and control
 Web Control interface: Full control via Web/Mobile UI includes Scene Presets



 BirdDog
P400

4K NDI® WITH PROFESSIONAL
LEVEL COLOUR CONTROL.



 BirdDog | P400

Stunning 4K NDI® with incredible colour tools.

P400 features stunning 4K resolution NDI and allows chroma subsampling in your choice of 4:2:0 or 4:2:2. Wow.

P400 teams up BirdDog's custom NDI® silicon chip, a 4K Sony CMOS Backlit sensor, and a true Sony Image Module. Double Wow.

P400 includes professional-level colour tools including Colour Matrix control, Black level, Gamma including 512 pre-set gamma positions. Triple Wow.

4:2:2 4K. Numbers matter.

P400 debuts the world's first 4K NDI with chroma subsampling at 4:2:2 which can be decoded natively in hardware by BirdDog's 4K Family of NDI Encoders and Decoders. If decoding with a 4:2:0 receiver the stream will automatically serve 4:2:0 and this is what will be decoded. Think of it as an automatic and virtual handshake.

Cam Control. Shade like a pro, bro.

BirdDog Cam Control allows full access to the entire colour matrix, black levels, and even the gamma to be able to shade your P400's like a total pro. Right click to view camera full screen on a secondary monitor to

really dial in the look you want and then copy the settings to colour match cameras in seconds. Yes that's right. Colour match cameras in seconds.

Incredible low light performance.

In low light conditions the camera automatically switches from day to night mode, removing the IR-cut filter to boost sensitivity for clear pictures in near-darkness.

Triple output. NDI®, 6G-SDI & HDMI.

With NDI®, 6G-SDI, and HDMI simultaneous outputs, the P400 is ready to go live with your full NDI® workflow today or if you are still in an old school SDI workflow you can

use as an SDI camera and ease your way into the world of NDI® when you are ready. We'll be here to welcome you into the future with open arms.

Superfine Robotics.

P400's robotics are super precise and super sensitive. Wind down the panning and tilting speeds to create super professional shots that are dramatic, or crank up the speeds for high action sports to allow you to follow the movements.

The 20x optical zoom offers a bright F2.0 aperture with a super smooth and fast zoom. Transition from wide to tele and recall pre-set positions really quickly.



BOLIN

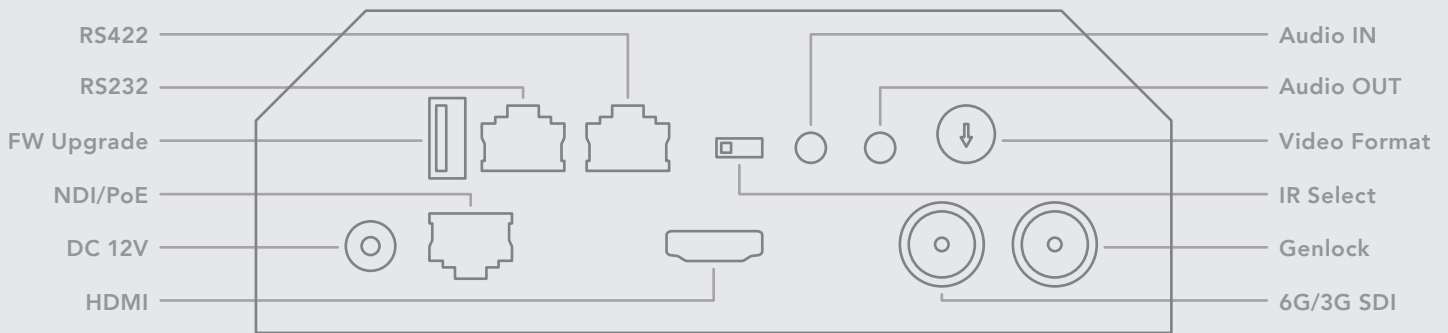

Product Specifications

CAMERA

Image Sensor: 1/2.5 inch CMOS 8.5MP
Lens: 4.4-88.4mm - **Optical Zoom:** 20x
SRZ (Super Resolution Zoom): 30X in 4K, 40X in FHD
Horizontal Angle of View: 70.2°(W) – 4.1°(T)
Aperture: F2.0 – F3.8
Min. Illumination: Color: 0.4lux (1/30s, 50%, High Sensitivity mode On), 1.6lux (1/30s, 50%, High Sensitivity mode Off), 0.06lux(1/4s(1/3s),50%, High Sensitivity mode On)
Shutter Speed: 1/1 – 1/10000s
Features: Defog (Auto, 3 levels), Visibility enhancer, Black & White, E-Flip, Mirror, Colour enhancement, Black level, gamma, Sat/Hue Adjust, HLC, Colour Bar
WDR: YES (130dB) • **Image Stabilizer:** YES
Color Gain: Yes (16 step) – **Color Hue:** Yes (16 step)
Gamma: Standard, Straight, 512 pattern
Gamma Level: Yes (72 step)
Black Level: Yes (97 step) - Flicker Cancel: Yes
Noise Reduction: On/Off (level 5 to 1/Off, 6 steps), 2D/3D • **S/N Ratio:** ≥50db

Focus: Auto Focus (Trigger/Interval), Manual Focus (Variable Speed), One Push Trigger, Near Limit
White Balance: AUTO, ATW, Indoor, Outdoor, One Push WB, Manual WB, Outdoor Auto, Sodium Vapor Lamp (Fix/Auto/Outdoor Auto)
Exposure: Full Auto, Gain, Gain Limit, Shutter Priority, Iris Priority, Manual, Bright, Slow Shutter, Max/Min Shutter Limit, Slow AE

Backlight Compensation: YES

MECHANICAL

Pan Movement: Horizontal: ±175° pan (Zoom Adaptive Speed Range: 0.05° to 100°/s)
Tilt Movement: Vertical: +90° to -30° (Zoom Adaptive Speed Range: 0.05° to 50°/s)
Preset 128 Speed adjustable: Up to 150°/s
Environmental: Indoor
Operating Temperature: -10 – +40 (°C)
Operating Humidity: ≤80%

VIDEO INTERFACE

Video Output: NDI/HDMI/6G-SDI
4K Video Formats: 4Kp 30, 29.97, 25, 23.98, 24,
HD Video Formats: 1080p 60, 59.94, 50, 29.97, 25, 1080i 60, 59.94, 50 • 720p 60, 59.94, 50
Audio I/O (Mono): 3.5mm Audio In / 3.5mm Audio Out

CONTROL INTERFACE

IP PTZ Control: NDI Control (auto config.), VISCA IP
Serial PTZ Control: 2x RJ45: RS232 / RS422 / RS485
Serial Control Protocol: VISCA / PELCO D

POWER & DIMENSIONS

Power Input: 12V DC, PoE+ (IEEE 802.3at)
Dimensions: 142x159x217mm • **Weight:** 2.7Kg

NETWORK

Video Compression: Full NDI – i-frame high quality low latency NDI for production
Network Protocol: NDI – Discovery, config. and control

Web Control interface: Full control via Web/Mobile UI includes Scene Presets

Optional Mounts: Ceiling mount, Wall mount



 **BirdDog | P4K**

**THE HIGHEST QUALITY FULL NDI®
CAMERA ON THE PLANET.**

 **BirdDog | P4K**

Hello Sony 1" Sensor. Meet NDI.

P4K is the real deal. A huge 1" Sony Exmor R CMOS back lit Sensor and 14.4 million effective pixels enable P4K to deliver stunning pictures in 4K resolutions with Full Bandwidth NDI®. Excellent light sensitivity makes P4K perfect for all broadcast applications, sports, remote studios, newsrooms, house of worship and any shoot where quality matters.

Sony 1" Sensor. Size does matter.

The best images come from the best sensors and the P4K is built exclusively around the best sensor in its category. The massive 1" Sony Exmor R CMOS backlit sensor delivers truly stunning pictures in all shoot modes and frame rates whether in HD or 4K.

Full NDI. No compromises.

In the world of NDI® there are two flavours, NDI® and NDIHX. NDI® is a variable bit rate, I-Frame codec that reaches around 140Mbps at 1080p60 and is visually lossless. NDIHX is a compressed, long-GOP, H.264 variant that reaches around 12Mbps at 1080p60. P4K is a Full NDI® camera.

More than just a production PTZ. Shoot true cinematic styles.

P4K is a PTZ designed for the most demanding live production shoots and supports all the traditional frame rates you would expect including 29.97 but now you can use your PTZ as a camera for TVC's, drama, and shoot 24p for that wonderful cinematic look.

Advanced Colour Controls.

With user selectable gamma settings and black gamma adjustment, fine tuning your shot has never been more flexible in a PTZ. Sony's legendary sensor technology sets the tone for your next quality production.

Superfine Robotics. Precise control at your fingers.

P4K's robotics are super precise and super sensitive. Wind down the panning and tilting speeds to create super professional shots that are dramatic, or crank up the speeds for high action sports to allow you to follow the movements.

360 degree Tally lights.

The front, rear, and side Tally lights combine to create a 360 degree Tally light. Now everyone on the production set can see which camera is live to air.



BOLIN

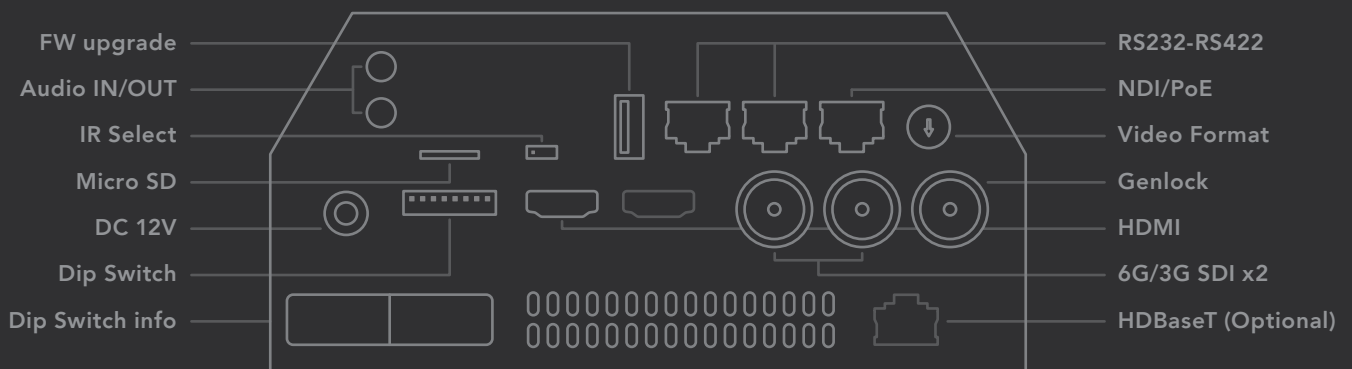

Product Specifications

CAMERA

Image Sensor: 1.0-type back-illumin. Exmor R CMOS sensor
Number of effective pixels: 14.2 Megapixels
Picture elements: 3840 x 2160, 8.29 Megapixels
Lens: Optical, 12x
Digital Zoom: Digital Zoom 12x, with SRZ feature, 18x zoom at 4K, or 24x zoom at FHD.
Horiz. Ang. of View Focal Length: 64.6 (Wide) – 6.1 (Tele), f=9.3 to 111.6mm, F2.8(Wide), F4.5(Tele)
Min. object distance: 80mm (W), 1000mm (T)
Aperture: F2.8 Constant (W)~(T), 16 Steps
Min. Illumination: 0.5 lux (1/30 sec, 50%, Hi-Sen. mode On) 2.0 lx (1/30 sec, 50%, High Sensitivity mode Off) 0.067 lx (1/4 sec (1/3 sec), 50%, High Sensitivity mode On) 0.267 lx (1/4 sec (1/3 sec), 50%, High Sensitivity mode Off)
Shutter Speed: 1/10000s to 1/8 (59.94/29.97)
Focus: Auto Focus (Trigger/Interval), Manual Focus (Variable Sp.), One Push Trigger, Near Limit
White Balance: AUTO, ATW, Indoor, Outdoor, One Push WB, Manual WB, Outdoor Auto, Sodium Vapor Lamp(Fix/Auto/Outdoor Auto)
Exposure: Full Auto, Gain, Gain Limit, Shutter Priority, Iris Priority, Manual, Bright,

Slow Shutter, Max/Min Shutter Limit, Slow AE
Features: High Sensitivity, Defog mode, Backlight Comp., HLC, E-FLIP, Mirror, Flicker Control, Day/Night, Defog
WDR: YES (130dB) - **ND Filter:** YES
Image Stabilizer: YES
Color Gain: Yes (15 step) - **Color Hue:** Yes (15 step)
Gamma: Standard/Straight/MOVIE/STILL/CINE1/CINE2/CINE3/CINE4/ITU709/Pattern
Gamma Level: Yes (15 step)
Black Level: Yes (97 step) - **Flicker Cancel:** Yes
Noise Reduction: On/Off (level 5 to 1/Off, 6 steps), 2D/3D
S/N Ratio: ≥50db
MECHANICAL
Pan Movement: Horiz.: ±175° pan (Zoom Adaptive Speed Range: 0.05° to 100°/s)
Tilt Movement: Vertical: +90° to -30° (Zoom Adaptive Speed Range: 0.05° to 50°/s)
Preset Position/Speed: 0~5 Level Adjustable
Preset Memory: YES, (Picture Profile Preset-Preset Memory for image parameters)
Quietness: 45db
Home Position: Supported - **Environmental:** Indoor
INTERFACE
4K Video Output: Main 4K HDMI Type-A (x1) 6G-SDI (x2) or Dual Link 3G-SDI (2SI only) x2

HD Video Output: Main HD HDMI Type-A (x1) - 3G-SDI x2
HDMI Color Space: YCbCr, 4:2:2 RGB, 4:4:4
NDI Video Encode: Full bandwidth NDI
IP Video Stream: Up to 4K/30 & 1080p60
Camera Control Interface: RS232/RS422/RS485(RJ45 x2), NDI/IP Control (RJ45), IR Remote Control
Control Protocol: NDI, VISCA, VISCA IP
LAN: RJ45 x1(1GbE), NDI/IP video streaming, System upgrade, PoE+ (IEEE 802.3at)
Analogue Audio I/O
 3.5mm Audio In (Mono), 3.5mm Audio Out (Mono)
Audio Output:
 Embedded with main HDMI, 24bit Stereo
 Embedded with SDI, 24bit Stereo. Embedded with NDI
360° Tally: Front, Side, Back
ENVIRONMENTAL
Optional Mounts: Ceiling mount, Wall mount, Tripod
Operating Temperature : -10 to +40 (°C), 32 to 104 (°F)
Operating Humidity: ≤80% Suitable for Use
Power Input: 12V DC, PoE+ (IEEE 802.3at)
Power Consumption: 22W
Dimension: 165x196x247mm
Weight: 3.4Kg



BirdDog | A200 • GEN 2

Weatherproof Full NDI® PTZ.

Designed for fixed outdoor installations such as sports, the IP67 rating means A200 can withstand pretty much any weather conditions. By teaming up BirdDog's custom NDI® silicon chip, a Sony CMOS backlit sensor, and a true Sony Image module A200 has lightning auto focus, incredibly sharp images, and insanely fast zoom.

A200 has frame rates up to 1080p60, 30x optical zoom, and outputs SDI and Full NDI® simultaneously.

Full NDI®.

In the world of NDI there are two flavours, NDI® and NDIHX. NDI® is a variable bit rate, I-Frame codec that reaches around 140Mbps at 1080p60 and is visually lossless. NDIHX is a compressed, long-GOP, H.264 variant that reaches around 12Mbps at 1080p60. Eyes A200 hardware only Encodes and Decodes Full YUV422 NDI®.

NDI® & SDI.

With NDI® and SDI simultaneous outputs the A200 is ready to go live with full NDI® today or can be used as a traditional SDI camera.

Sony Sensor.

The best pictures come from the best silicon. A200 teams up a world class Sony CMOS Backlit Sensor with the BirdDog custom NDI® chip to form a match made in silicon heaven. Your productions deserve the best.

Sony Image Module.

Lightning auto focus. Insanely fast zoom. Precision optics. The only way to achieve the best picture quality is with image module made by the world's best.

A200 uses a true Sony image module to give unparalleled performance, picture quality, and responsiveness.

All weather.

With an IP67 rating, external housing corrosion resistance treatment against salt spray, and an -40°C to +60°C operating temperature rating, A200 has been designed to withstand the most extreme elements on earth. It even has a rain wiper to keep water off the lens.

30x Optical zoom.

30x optical zoom makes A200 perfect for outdoor and indoor fixed installations for sports such as football, baseball, hockey, ski fields, basketball, soccer, and more.



BOLIN

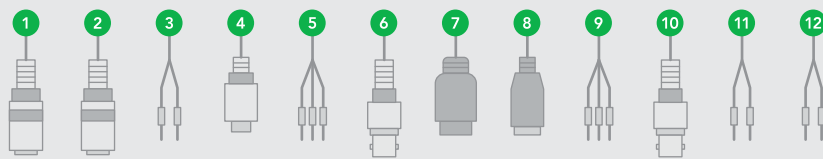

1. Audio Input • 2. Audio Output • 3. RS422 Connector (Combine with 11) • 4. Upgrade Interface • 5. Alarm Input
 6. BNC Connector: 3G-SDI video output • 7. RJ45 Ethernet Port • 8. AUX DC12V Output • 9. AC Power Connector
 10. BNC Connector: Analog video output • 11. RS485/RS422 Connector (Combine with 3) • 12. Alarm Output

Product Specifications

Camera

Image Sensor: 1/2.8" CMOS 2.13MP
Lens: 4.3 - 129mm
Optical Zoom: 30x
Digital Zoom: 12x
Horizontal Angle of View:
 63.7° (W) – 2.3° (T)
Aperture: F1.6 (W) – F4.7 (T)
Min. Illumination: Color: 0.01 lux (F1.6, AGC on, 1/30s, High sensitive mode), 0.1 lux (F1.6, AGC on, 1/30s, Normal sensitive mode)
Shutter Speed: 1/1 – 1/10000s
Focus: Auto, Push, Manual
White Balance: Auto, Indoor, Outdoor, Manual, OPW, ATW
Exposure: Auto, Manual, Shutter/Iris Priority
Backlight Compensation: YES

Mechanical

Pan Movement: Horizontal: 360° continuous pan (Zoom Adaptive Speed Range: 0.01° to 150°/s)
Tilt Movement: Vertical: -90° to +15° (Zoom Adaptive Speed Range: 0.05° to 90°/s)
Preset Positions: 255 (Speed adjustable: Up to 150°/s)
Environmental: Outdoor/Indoor, IP67, corrosion resistant treated housing
Operating Temperature: -40 – +60 (°C)
Operating Humidity: ≤80%
Video Interface
Video Output: NDI/SDI
Video Formats: 1080p 60, 59.94, 50, 29.97, 25
 1080i 60, 59.94, 50 • 720p 60, 59.94, 50
Audio I/O: 3.5mm Audio In (Stereo)
 3.5mm Audio Out (Stereo)

Control Interface

IP PTZ Control: NDI Control (auto configuring)
 VISCA IP
Serial PTZ Control: RS422/RS485 connector
Serial Control Protocol: VISCA / PELCO D
Power & Dimensions
Power Input: AC 24V, PoE 97W (BirdDog PoE 97W Injector, optional)
Power Consumption: Min: 22W; Max: 51.84W (Fully loaded operation)
Weight: 5.5Kg
Network
Video Compression: Full NDI – i-frame high quality low latency NDI for production
Network Protocol: NDI – Discovery, configuration and control
Web Control interface: Full control via Web/Mobile UI includes Scene Presets



BirdDog | A300 • GEN 2

Weatherproof Full NDI® PTZ.

Designed for fixed outdoor installations such as sports, the IP67 rating and the Wind Load Durability rating equal to that of a category 4 Hurricane, which means A300 can withstand pretty much any weather conditions. By teaming up BirdDog's custom NDI® silicon chip, a Sony CMOS backlit sensor, and a true Sony Image module A300 has lightning auto focus, incredibly sharp images, and insanely fast zoom. A300 has frame rates up to 1080p60, 30x optical zoom, and outputs SDI and Full NDI® simultaneously.

Full NDI®.

In the world of NDI there are two flavours, NDI® and NDIHX. NDI® is a variable bit rate, I-Frame codec that reaches around 140Mbps at 1080p60 and is visually lossless. NDIHX is a compressed, long-GOP, H.264 variant that reaches around 12Mbps at 1080p60.

Eyes A300 hardware only Encodes and Decodes Full YUV422 NDI®.

NDI® & SDI.

With NDI® & SDI simultaneous outputs the A300 is ready to go live with full NDI® today or can be used as a traditional SDI camera.

Sony Sensor.

The best pictures come from the best silicon. A300 teams up a world class Sony CMOS Backlit Sensor with the BirdDog custom NDI® chip to form a match made in silicon heaven. Your productions deserve the best.

Sony Image Module.

Lightning auto focus. Insanely fast zoom. Precision optics. The only way to achieve the best picture quality is with an image module made by the world's best.

A300 uses a true Sony image module to give unparalleled performance, picture quality, and responsiveness.

All weather.

With an IP67 rating, external housing corrosion resistance treatment against salt spray, and an -40°C to +60°C operating temperature rating, A300 has been designed to withstand the most extreme elements on earth. It can even work through a category 4 hurricane.

30x Optical zoom.

30x optical zoom makes A300 perfect for outdoor and indoor fixed installations for sports.

Nitrogen Filled Housing.

Nitrogen filled housing eliminates fog.



BOLIN

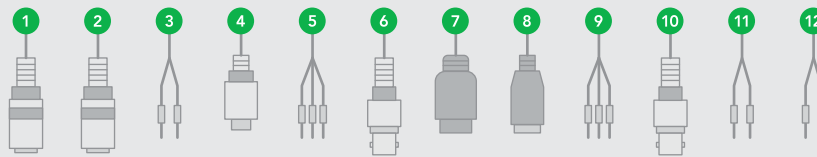

1. Audio Input • 2. Audio Output • 3. RS422 Connector (Combine with 11) • 4. Upgrade Interface • 5. Alarm Input
 6. BNC Connector: 3G-SDI video output • 7. RJ45 Ethernet Port • 8. AUX DC12V Output • 9. AC Power Connector
 10. BNC Connector: Analog video output • 11. RS485/RS422 Connector (Combine with 3) • 12. Alarm Output

Product Specifications

<p>Camera Image Sensor: 1/2.8" CMOS 2.13MP Lens: 4.3 - 129mm Optical Zoom: 30x Digital Zoom: 12x Horizontal Angle of View: 63.7° (W) – 2.3° (T) Aperture: F1.6 (W) – F4.7 (T) Min. Illumination: Color: 0.01 lux (F1.6, AGC on, 1/30s, High sensitive mode), 0.1 lux (F1.6, AGC on, 1/30s, Normal sensitive mode) Shutter Speed: 1/1 – 1/10000s Focus: Auto, Push, Manual White Balance: Auto, Indoor, Outdoor, Manual, OPW, ATW Exposure: Auto, Manual, Shutter/Iris Priority Backlight Compensation: YES</p>	<p>Mechanical Pan Movement: Horizontal: 360° continuous pan (Zoom Adaptive Speed Range: 0.01° to 80°/s) Tilt Movement: Vertical: +90° to -30° (Zoom Adaptive Speed Range: 0.1° to 90°/s) Preset Positions: 255 (Speed adjustable: Up to 150°/s) Environmental: Outdoor/Indoor, IP67, corrosion resistant treated housing, wind load durability 60m/s, Nitrogen filled housing Illumination: IR Laser, up to 500m Operating Temperature: -40 – +60 (°C) Operating Humidity: ≤80% Infrared: Adaptive infrared, illumination up to 100m</p> <p>Video Interface Video Output: NDI/SDI Video Formats: 1080p 60, 59.94, 50, 29.97, 25 1080i 60, 59.94, 50 • 720p 60, 59.94, 50 Audio I/O: 3.5mm Audio In (Stereo) 3.5mm Audio Out (Stereo)</p>	<p>Control Interface IP PTZ Control: NDI Control (auto config.), VISCA IP Serial PTZ Control: RS422/RS485 connector Serial Control Protocol: VISCA / PELCO D</p> <p>Power & Dimensions Power Input: AC 24V, PoE 97W (BirdDog PoE 97W Injector, optional) Power Consumption: Min: 36W; Max: 76.68W (Fully loaded operation with heater and IR Laser on) Dimensions: 180x180x423mm Weight: 10.2Kg</p> <p>Network Video Compression: Full NDI – i-frame high quality low latency NDI for production Network Protocol: NDI – Discovery, configuration and control Web Control interface: Full control via Web/Mobile UI includes Scene Presets</p>
--	---	---



BirdDog | PTZ KEYBOARD

World's first NDI® PTZ Controller.

BirdDog PTZ Keyboard is a full featured PTZ Keyboard that supports NDI®, NDIHX, Visca over IP, RS422, and RS232. By harnessing BirdDog's next generation NDI® and IP technology, it's never been easier to discover, connect, and control your PTZ cameras. Featuring superior ergonomics, premium buttons and joystick, all in a beautiful form factor this is the PTZ controller you have been waiting for.

Mix and Match protocols.

Never before has a PTZ controller been so flexible. PTZ Keyboard is the world's first PTZ controller with NDI® and NDIHX support. Along with NDI® there is support for Visca over IP, RS422, and RS232. You can mix and match any of the supported protocols and control them from a single PTZ Keyboard.

Superior Ergonomics.

Using the PTZ Keyboard is a breeze with well thought out button layout. Quickly access all the cameras on the network, and set up quick access buttons for your favourite settings like Exposure, Focus, Zoom, and movement speeds.

3-Way Joystick.

Effortless, one handed control of Pan, Tilt, and Zoom is possible with the 3-Way Joystick. For those who prefer a zoom rocker there is also one of those exactly where your left hand wants it.

Soft touch buttons.

Your fingers will thank you for using the PTZ Keyboard. Soft-touch silicon buttons and easy turn dials give a premium sensation while achieving the responsiveness you expect and deserve.

Control 255 cameras.

Designed to control up to 255 PTZ cameras on a single network, PTZ Keyboard can scale to even the most complex installations.

6 program buttons.

Set up your quick access buttons to work the way you want. Exposure, Focus, PT Speed, Zoom, Shutter Speed, Iris, White Balance, Compensation, and more, can all be programmed into the assignable buttons.

PoE or DC.

P200 can be powered by Power over Ethernet (PoE) or from the included power adapter.

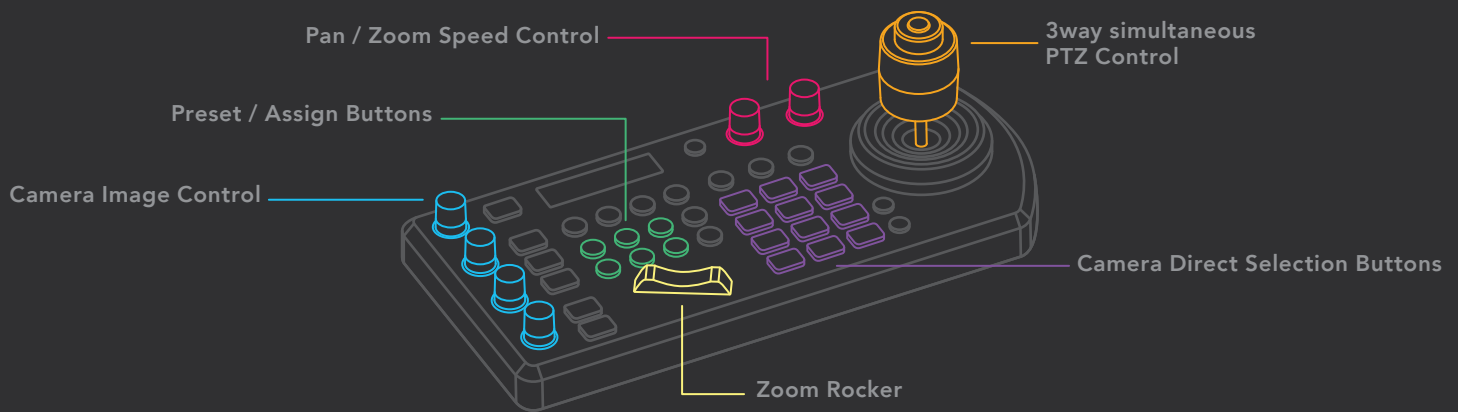
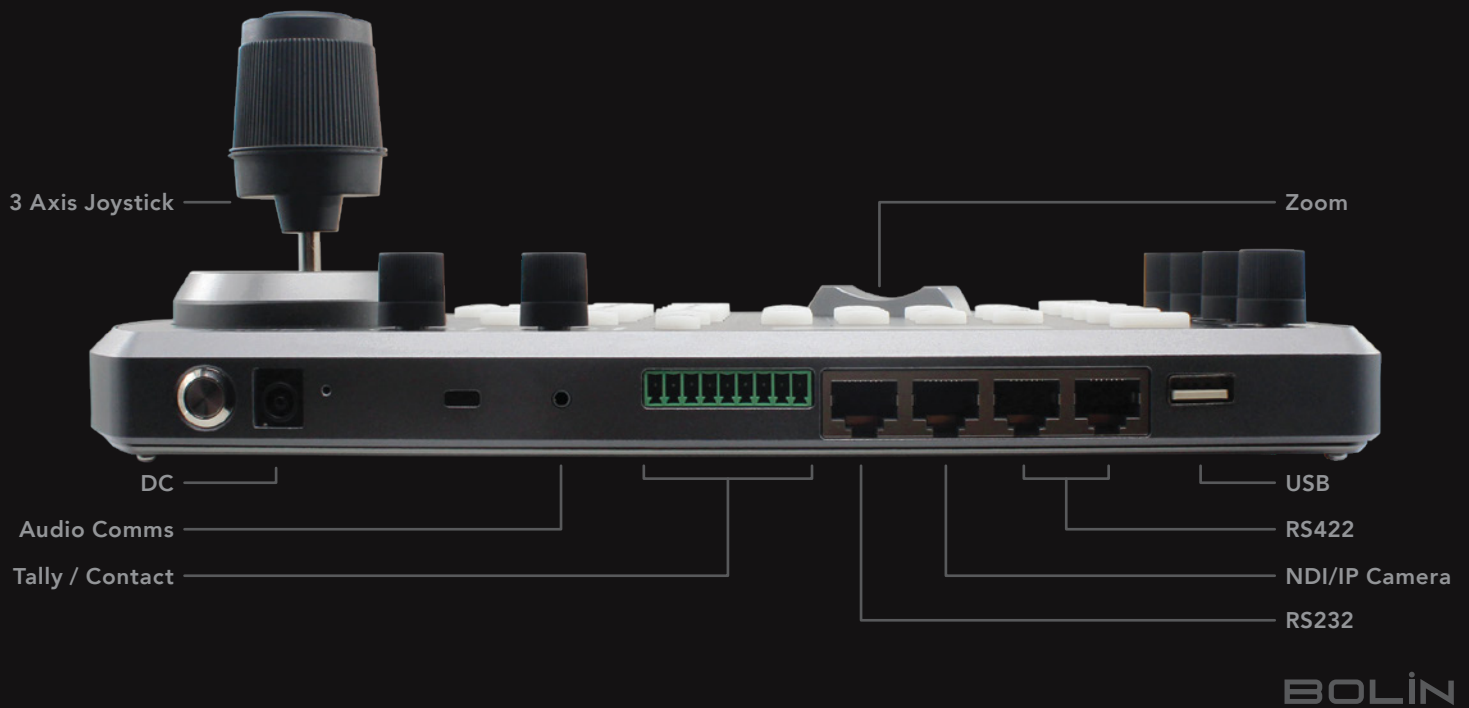

Product Specifications

Input/Output Connectors

Control Input/Output

LAN: RJ45 x1 (With PoE) 100 BASE-TX

RS232: RJ45 x1 • **RS422:** RJ45 x2

Audio: Analog 3.5mm Mic/Headphone

Control signal format

NDI® Control

VISCA over IP

RS 232/RS422: Baud Rate

2400/4800/9600/19200/38400

(Sony VISCA Compatible)

User Interface

Display: LED

Speed control: Yes, 2 knobs (pan/tilt, zoom)

Zoom rocker: Yes

Joystick zoom ring: Yes

Programmable function buttons: 6

Camera Control

Maximum camera control: Max. 255 with multiple protocols including NDI/IP

Maximum serial connections

RS232: 7

RS422: 7 x 2 (A/B)

Key/Button illumination: Multi-colour LED Buttons

Exposure Selection: Yes, Button

One push White balance: Yes, Button

Backlight control: Yes, Button

Display status of WB, Iris, Gain, Shutter, Focus: Yes

White balance model selection: Yes, Button

R, B, Gain: Yes, Knob

Iris Adjustment: Yes, Knob

Shutter Speed: Yes, Knob

Focus model selection: Yes, Button

One push auto focus: Yes, Button

Manual focus: Yes, Knob

General

Power input: DC 12V, PoE (Power over Ethernet), Power via RS232/RS422 port

Power: 3W

Operating Temp: 0 - 40 °C

Dimensions: 278x132x99.5

Notes:

Not all features are available on all control protocols.

PTZ CAMERAS

Features & Specifications Comparison

Feature/Specification	P100	P200	A200	A300
CAMERA				
Image Sensor	1/2.86" CMOS 2.2MP	1/2.8" CMOS 2.13MP		
Lens	4.7 - 47mm	4.3-129mm		
Optical Zoom	10x	30x		
Digital Zoom	12x	No	12x	
Horizontal Angle of View	60.9° (W) – 6.43° (T)	63.7° (W) – 2.3° (T)		
Aperture	F1.6 (W) – F3.0 (T)	F1.6 (W) – F4.7 (T)		
Min. Illumination	0.5 lux	Color: 0.01 lux (F1.6, AGC on, 1/30s, High sensitive mode), 0.1 lux (F1.6, AGC on, 1/30s, Normal sensitive mode)		
Shutter Speed	1/1 – 1/30000s	1/1 – 1/10000s		
Focus	Auto, Push, Manual			
White Balance	Auto, Indoor, Outdoor, Manual, OPW, ATW			
Exposure	Auto, Manual, Shutter/Iris Priority			
Backlight Compensation	YES			
MECHANICAL				
Pan Movement	Horizontal: ±175° *		Horizontal: 360° continuous pan *	
Tilt Movement	Vertical: +90° to -30° *		Vertical: -90° to +15° *	Vertical: +90° to -30° *
Preset Positions	128 (Speed adjustable: Up to 150°/s)		255 (Speed adjustable: Up to 150°/s)	
Preset Speed	0-5 Level adjustable		-	
Environmental	Indoor		Out/Indoor, IP67, corrosion resistant treated housing	Out/Indoor, IP67, corrosion resistant treated housing, wind load durability 60m/s, Nitrogen filled housing
Operating Temperature	-10 – +50 (°C)		-40 – +60 (°C)	
Operating Humidity	≤80%			
Infrared	-		Adaptive, illum. up to 100m	IR Laser, up to 500m
VIDEO INTERFACE				
Video Output	NDI/HDMI/SDI/USB	NDI/HDMI/SDI	NDI/SDI	
Video Formats	1080p 60, 59.94, 50, 29.97, 25 • 1080i 60, 59.94, 50 • 720p 60, 59.94, 50, 29.97, 25			
Audio I/O	3.5mm Audio In (Stereo) - 3.5mm Audio Out (Stereo)			
CONTROL INTERFACE				
IP PTZ Control	NDI Control (auto configuring), VISCA IP			
Serial PTZ Control	2x RJ45: RS232/RS422/RS485			
Serial Control Protocol	VISCA / PELCO D			
POWER & DIMENSIONS				
Power Input	12V DC, PoE+ (IEEE 802.3at)	12V DC, PoE+ (IEEE 802.3at)	AC 24V, PoE 97W (BirdDog PoE 97W Injector, optional)	
Power Consumption	Min. 11.1W Max. 15.2W	Min. 15.2W Max. 19.7W	Min. 22W Max. 51.84W	Min. 36W Max. 76.68W (IR Laser ON)
Dimensions	145x145x154mm	160x178x220mm	210x210x333mm	180x180x423mm
Weight	1.0Kg	2.0Kg	5.5Kg	10.2Kg
NETWORK				
Video Compression	Full NDI – i-frame high quality low latency NDI for production			
Network Protocol	NDI – Discovery, configuration and control			
Web Control interface	Full control via Web/Mobile UI inc. Scene presets			

* Check Zoom Adaptive Speed Range on the single camera page.

Feature/Specification	P400	P4K
CAMERA		
Image Sensor	1/2.5 inch CMOS 8.5MP	1.0-type back-illuminated Exmor R CMOS sensor 14.2MP
Lens	4.4-88.4mm	Zeiss Vario-Sonnar T lens
Optical Zoom	20x	12x
Digital Zoom	SRZ (Super Revolution Zoom) 30x in 4K, 40x in Full HD	12x, with SRZ feat., 18x zoom at 4K, or 24x zoom at FHD
Horizontal Angle of View	70.2° (W) – 4.1° (T)	64.6 (Wide) – 6.1 (Tele), f=9.3 to 111.6mm, F2.8(Wide),
Aperture	F2.0 (W) – F3.8 (T)	F4.5(Tele)
Min. Illumination	Color: 0.4lux (1/30s, 50%, High Sensitivity mode On), 1.6lux (1/30s, 50%, High Sensitivity mode Off), 0.06lux(1/4s(1/3s),50%, High Sensitivity mode On)	F2.8 Constant (W)~(T), 16 Steps 0.5 lx (1/30 sec, 50%, High Sensitivity mode On) 2.0 lx (1/30 sec, 50%, High Sensitivity mode Off) 0.067 lx (1/4 sec (1/3 sec), 50%, High Sensitivity mode On) 0.267 lx (1/4 sec (1/3 sec), 50%, High Sensitivity mode Off)
Shutter Speed	1/1 – 1/10000s	1/10000s to 1/8 (59.94/29.97)
Focus	Auto Focus (Trigger/Interval), Manual Focus (Variable Speed), One Push Trigger, Near Limit	
White Balance	AUTO, ATW, Indoor, Outdoor, One Push WB, Manual WB, Outdoor Auto, Sodium Vapor Lamp (Fix/Outdoor/Auto)	
Exposure	Full Auto, Gain, Gain Limit, Shutter Priority, Iris Priority, Manual, Bright, Slow Shutter, Shutter Limit, Slow AE	
Features	High Sensitivity, Backlight Compensation, HLC, E-FLIP, Mirror, Day/Night, Visibility Enhancer, Black Level, WDR, ND Filter, Image Stabiliser, Color Gain, Color Hue, Gamma, Gamma Level, Flicker Cancel, Noise Reduction	
S/N Ratio	≥50dB	
MECHANICAL		
Pan Movement		
Tilt Movement	Vertical: +90° to -30° (Zoom Adaptive Speed Range: 0.05°~50°/S)	
Preset Positions	128 (Speed adjustable: Up to 150°/S, 6 presets on remote controller)	
Preset Speed	0~5 Level Adjustable	
Preset Memory	YES, (Picture Profile Preset-Preset Memory for image parameters)	
Environmental	Indoor	
Quietness	49dB	
Home Position	YES	
Operating Temperature	-10 to +40 (°C)	
Operating Humidity	≤80%	
INTERFACE		
Video Output	NDI/HDMI/6G-SDI	4K: Main 4K HDMI Type-A (x1) 6G-SDI (x2) or Dual Link 3G-SDI(2SI only) x2. HD: Main HD HDMI Type-A (x1) 3G-SDI x2
4K Video Formats	2160p 30, 29.97, 25, 23.98, 24	
HD Video Formats	1080p 60, 59.94, 50, 30, 29.97, 25 • 1080i 60, 59.94, 50 • 720p 60, 59.94, 50	
HDMI Color Space	YCbCr, 4:2:2 RGB, 4:4:4	
NDI Video Encode	Full bandwidth NDI	
IP Video Stream	Up to 4K/30 and 1080p60	
Camera Control Interface	RS232/RS-422/RS485(RJ45 x2), NDI/IP Control (RJ45), IR Remote Control	
Control Protocol	NDI, VISCA, VISCA IP	
LAN	RJ45X1(1000Mb), NDI/IP video streaming, System upgrade, PoE+ (IEEE 802.3at)	
Audio I/O	3.5mm Audio In (Mono) - 3.5mm Audio Out (Mono)	
Tally Light	Front	Front and Back
POWER & DIMENSIONS		
Power Input	12V DC, PoE+ (IEEE 802.3at)	
Power Consumption	Min. 23.2W - Max. 26.8W	Min. 22.4W - Max. 28W
Dimensions	142x159x217mm	165x196x247mm
Weight	2.7Kg	3.4Kg
NETWORK		
Video Compression	Full NDI – i-frame high quality low latency NDI for production	
Network Protocol	NDI – Discovery, configuration and control	
Web Control Interface	Full control via Web/Mobile UI inc. Scene presets	

FREE

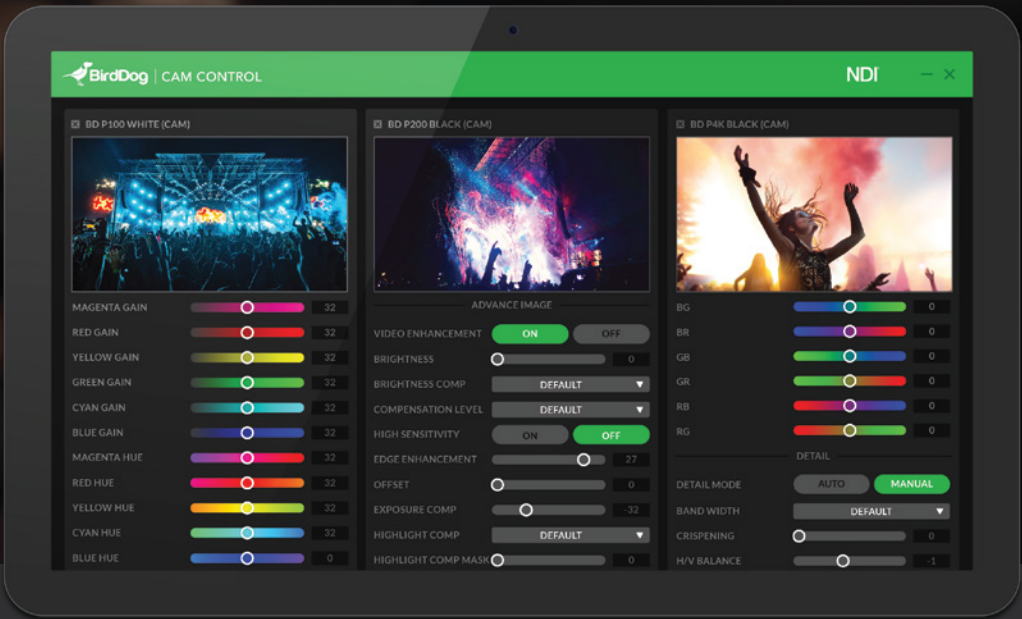

BirdDog | CAM CONTROL

Colour match cameras in seconds.

The free Cam Control app is the easiest and most user-friendly way to dial in BirdDog cameras. Simply load on a Windows 10 machine on the same network as your BirdDog cameras and access all functions of the camera through a beautiful interface. Quickly dial in the look you like and easily match multiple cameras.

Realtime Sync.

The unparalleled flexibility of BirdDog cameras means there are multiple ways to access each setting. You can use Cam Control for remote shading and colour matching, the On Screen Display (OSD) via the remote control, the controls on the BirdDog PTZ Keyboard, or by using the Web Dashboard. Now as soon as you make a change anywhere it will realtime sync to everywhere else.

P400 and P4K tools included.

P400 and P4K have an unbelievably powerful set of colour tools, exposure and gamma controls, and so many more powerful features. Now you have access to them all within Cam Control.

Save and Recall Pre-sets.

As if Cam Control wasn't already the fastest and easiest to use camera shading tool on the planet, you can also save and recall camera pre-sets. Load your saved settings up on your next job, copy across all cameras in just seconds, and then sit back and work out what you are going to do with all that time you just saved. We strongly suggest cat videos on YouTube.

Full Screen Confidence Monitor.

Load up the BirdDog PTZ cameras you want to work with and right click to output to a full screen confidence monitor to dial in the exact look you are after.

Direct text entry. Tuning made easy.

Slider bars are great for quick control but sometimes can be hard to dial in the exact levels you need. To change a value from 89 to 88, just click in the direct text box next to the slider bar and type 88. It's really that easy.

Scales with camera capabilities.

Some BirdDog cameras such as P4K have more colour adjustment capabilities such as black level and gamma control. If the camera supports these extra features the access to them will appear automatically in Cam Control.

Full user interface at bird-dog.tv/camcontrol

CONVERTERS



BirdDog | MINI

Pocket sized NDI®.

Big things come in small packages. Utilising BirdDog's custom NDI® silicon chip and housed in aircraft grade aluminium case, Mini is the ultimate entry point into the world of NDI® Encoding and Decoding. Featuring HDMI inputs and outputs, Active Loop Outs, Audio Intercom System, NDI® Tally System, PoE, and compatibility with BirdDog's Comms and Central Apps.

Full NDI®.

In the world of NDI® there are two flavours, NDI® and NDIHX. NDI® is a variable bit rate, I-Frame codec that reaches around 140Mbps at 1080p60 and is visually lossless. NDIHX is a compressed, long-GOP, H.264 variant that reaches around 12Mbps at 1080p60. Mini hardware only uses Full YUV422 NDI®.

NDI® Encode or Decode.

Built with total flexibility in mind, Mini can be configured as an NDI® Encoder or NDI® Decoder. In either Encode or Decode mode Mini is the perfect way to get your HDMI sources into and out of the world of NDI®.

Extreme Speed.

BirdDog's revolutionary custom silicon chip is what drives the best NDI® products on the planet. Only BirdDog's hardware can do line-based processing to give the fastest possible NDI® Encoding or Decoding technically possible.

Tally. It just works.

The world's first NDI® Tally system is built right into Mini and it requires zero configuration. Includes a built-in large Tally display for your on-air talent to easily see which camera is live, plus user selectable Tally borders on loop out, and an external Tally output.

Aircraft Grade Aluminium case.

It's easier to imagine Mini on display within the Louvre in Paris than on a live video production set, but that is where the deception of the senses first takes place. The perfectly finished casing is actually aircraft grade aluminium and designed to withstand the rigours of life on the road.

VESA or Camera Mount.

With the optional VESA and Camera mounts Mini is easy to mount. Use the VESA mount to attach to screens or use the camera mount for easy mounting with ball heads, magic arms, and other traditional mounting gear.



Included COMMS Lite & CENTRAL Lite - 100% FREE

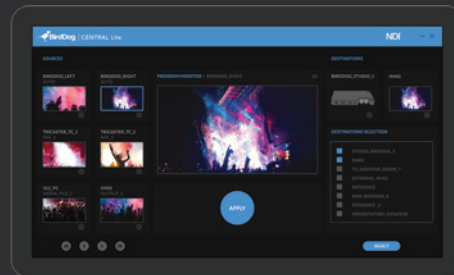
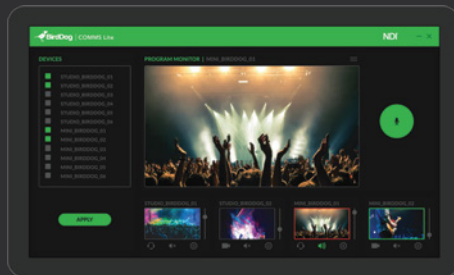

Product Specifications

Video Formats

(HD) 1080p 23.98, 25, 29.97, 30, 50, 59.94, 60
 (HD) 1080i 25, 29.97, 30
 (HD) 720p 50, 59.94, 60

Video Input

1 x HDMI Standard Type A connector HDMI v1.4a, RGB or YCbCr

Video output

1 x HDMI Standard Type A connector HDMI v1.4a, RGB or YCbCr

Audio digital

2-Channel, 24-bit HDMI embedded audio, 48 kHz sample rate, synchronous

Audio analog

3.5mm Microphone headset input / output

Video Codec support

Realtime, ultra-low latency, full-bitrate NDI (i-frame)

Display

Bicolor Tally (Red/Green)

Multicolour status information

Full status information on HDMI output (Selectable)

Network Interface

10/100/1000 Ethernet (RJ-45) with PoE (Power over Ethernet)

Embedded web configuration panel for control and firmware updates

User Interface Controls

Network settings
 Video settings

Tally settings

Audio and Comms

Size (WxDxH)

98x110x22mm

Weight

200g

Power

+5-18V DC 7W Max

Power over Ethernet (PoE) 802.3af/at



BirdDog | STUDIO NDI

The one that started it all.

Studio NDI is the world's flagship NDI® Encoder and Decoder. Built around BirdDog's custom NDI® silicon chip and housed in an aircraft grade aluminium case, Studio NDI has been engineered from the ground up for real-world users. Featuring SDI and HDMI inputs and outputs, built-in cross converter, active loop outs, audio intercom system, NDI® tally system, PoE, and compatibility with BirdDog's Comms and Central Apps, Studio NDI is the perfect addition to any live producers toolkit.

NDI® Encode or Decode.

Built with total flexibility in mind Studio NDI can be configured as an NDI® Encoder or NDI® Decoder. Studio NDI is capable of Encoding resolutions up to 1080p60 SDI and HDMI to NDI® and Decoding NDI® resolutions up to 1080p60 to SDI or HDMI.

Full NDI®. No compromises.

In the world of NDI® there are two flavours, NDI® and NDIHX. NDI® is a VBR, I-Frame codec that reaches around 140Mbits at 1080p60 and is visually lossless. NDIHX is a compressed, long-GOP, H.264 variant that reaches around 12Mbits at 1080p60. Studio NDI hardware is Full YUV422 NDI®.

Extreme Speed.

BirdDog's revolutionary custom silicon chip is what drives the best NDI® products on the planet. Only BirdDog's hardware can do line-based processing to give the fastest possible NDI® Encoding or Decoding technically possible.

Camera Mount.

A ¼-20" thread top and bottom allows for easy mounting on magic arms and other traditional camera mounting gear whilst the 7mm diameter through holes can be used for mounting on cheese plates. The optional camera mount adds a ¼-20 thread to the bottom for further mounting options.

Aircraft Grade Aluminium case.

It's easier to imagine Studio NDI on display within the Louvre in Paris than on a live video production set, but that is where the deception of the senses first takes place. The perfectly finished casing is actually aircraft grade aluminium and designed to withstand the rigours of life on the road.

Tally. It just works.

The world's first NDI® Tally system is built right into Studio NDI and it requires zero configuration. Includes a built-in large Tally display for your on-air talent to easily see which camera is live, plus user selectable Tally borders on loop out.



Included COMMS Lite & CENTRAL Lite - 100% FREE

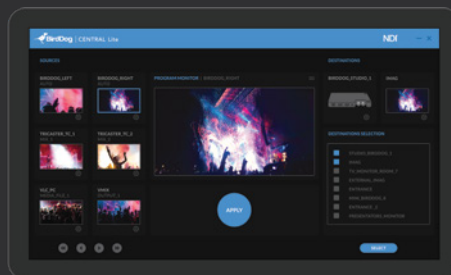
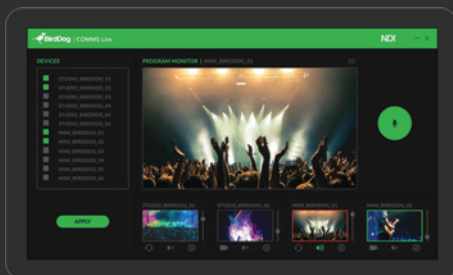

Product Specifications

Video Formats

(HD) 1080p 23.98, 25, 29.97, 30, 50, 59.94, 60

(HD) 1080i 25, 29.97, 30

(HD) 720p 50, 59.94, 60

Video Input

1 x 3G-SDI, SMPTE-259/292/296/424 (Level A / Level B)

1 x HDMI Standard Type A connector
HDMI v1.4a, RGB or YCbCr

Video Output

1 x 3G-SDI, SMPTE-259/292/296/424 (Level A)

1 x HDMI Standard Type A connector
HDMI v1.4a, RGB or YCbCr

Audio Digital

2-Channel, 24-bit SDI embedded audio, 48 kHz sample rate, synchronous

2-Channel, 24-bit HDMI embedded audio, 48 kHz sample rate, synchronous

Audio Analog

3.5mm Microphone headset input / output

Video Codec Support

Realtime, ultra-low latency, full-bitrate NDI (i-frame)

Display

Internal 35x5 tri-colour LED display for information and tally indication

Network Interface

10/100/1000 Ethernet (RJ-45) with PoE (Power over Ethernet)

Embedded web configuration panel for control and firmware updates

User Interface Controls

Network settings

Video settings

Tally settings

Audio and Comms settings

External Tally

3.5mm 2 position +5v tally connector

Size (W x D x H)

150mm x 105mm x 21mm

Weight

0.3kg

Power

100-240V, 50/60 Hz Universal Input, +5-18V DC 7W Max

Power over Ethernet (PoE) 802.3af/at



BirdDog | FLEX 4K FAMILY

The Smallest 4K NDI® on the Planet.

4K NDI® in an incredibly small package. Flex delivers everything you have come to expect from BirdDog's one cable solution including Tally, Audio Intercom, Video, Audio, PTZ Control, and Power all down a single Ethernet cable. With 3 models to choose from in the Flex Family is a Flex to perfect for your workflow needs.

Small is the new Big.

With a footprint only slightly larger than a credit card, the Flex 4K NDI Encoders and Decoders are the smallest on the planet. Because sometimes the biggest things are also the smallest.

One cable to rule them all. Now with added power.

BirdDog's revolutionary Studio NDI gave the world NDI, Power, Video, Audio, Tally, and Audio Intercom all done a single Ethernet cable. Flex 4K IN and Flex 4K BACKPACK take it one step even further and provides an additional 15w extra power allowing you to use the DC output to power your monitor, recorder, or even your camera.

Halo Tally. It just works.

Flex's revolutionary Halo Tally system is built right into the Flex Family and it requires zero configuration when connected with any NDI enabled software based production system. The Halo Tally is designed to be seen by the camera operators as well as the on air talent.

Flex 4K BACKPACK. Upgrade your monitor.

Flex BACKPACK is the ultimate upgrade for your camera top monitor recorder. Featuring an NP style battery connection, and 15w power output, it allows you to encode NDI, power your monitor, and record all at the same time. With great power comes great responsibility.

The ultimate PTZ sidekick.

If you aren't lucky enough to own a BirdDog PTZ camera with full NDI natively then Flex can become the ultimate sidekick. Plug in HDMI to encode beautiful and Full NDI, and attach a PTZ control cable to have PTZ passthrough control. Perfect upgrade for your PTZ camera while waiting for Santa to bring you a BirdDog.

Cool touch thermals.

Sometimes the biggest features are also the least obvious. Flex 4K NDI has unmatched thermal design and whisper quiet fans to keep Flex cool and fresh even on the hottest days and in direct sunlight.



FLEX 4K IN

4K BACKPACK

FLEX 4K OUT

Feature/Specification	FLEX 4K IN	FLEX 4K OUT	4K BACKPACK
SUPPORTED VIDEO FORMATS			
UHD 2160p		25.00, 29.97, 30.00	
HD 1080p		25.00, 29.97, 30.00, 50.00, 59.94, 60.00	
HD 1080i		50.00, 59.94	
HD 720p		50.00, 59.94, 60.00	
VIDEO I/O CONNECTIVITY			
HDMI 2.0 Input	✓	-	✓
HDMI 2.0 Output	-	✓	-
AUDIO INPUT			
HDMI	2Ch, 48kHz	-	2Ch, 48kHz
3.5mm AUDIO	Microphone/line input		
AUDIO OUTPUT			
HDMI	-	2Ch, 48kHz	-
3.5mm AUDIO	Stereo Headphone/Line Output		
VIDEO CODEC SUPPORT			
NDI (Full bandwidth i-frame compression)	✓	✓	✓
TALLY			
Integrated tricolour Halo Tally	✓	✓	✓
PTZ CONTROL			
2.5mm 4-pole RS232 (VISCA)	✓	✓	✓
NETWORK CONNECTIVITY			
Ethernet RJ45 1000baseT w/integrated PoE (Power over Ethernet)	✓	✓	✓
Embedded Web configuration Panel	✓	✓	✓
WEIGHTS & DIMENSIONS			
Size	107x63x31mm	107x63x31mm	107x63x42.5mm
Weight	140g	140g	150g
POWER			
PoE (Power over Ethernet)	PoE+ 802.3at		
DC Input	DC 12V (30W max)		
DC Output	DC 12V (15W max)	-	DC 12V (15W max)
NP style Battery Output	-	-	✓

4K HDMI 4K 12G SDI 4K QUAD



BirdDog | 4K FAMILY

Next Level NDI® Tools.

Following on from the award winning HD NDI® products, the 4K Family has been engineered from the ground up for real-world users. Built around BirdDog's custom NDI® silicon chip and housed in an aircraft grade aluminium case, features include 12G SDI and HDMI 2.0 inputs and outputs, built-in cross converter, SFP+ port for 10GbE connectivity, active loop out, audio intercom system, NDI® tally system, PoE, and compatibility with BirdDog's Comms Pro and Central Pro apps.

Encode & Decode up to 4Kp60.

With support for all resolutions up to 4Kp60, including all HD resolutions, Encoding and Decoding 4K Full NDI® has never been easier.

12G & HDMI 2.0 connections.

All SDI connectors on the 4K line are 12G SDI, including all four SDI connectors on 4K Quad. All the HDMI connectors are 2.0 for maximum compatibility with your sources and destinations.

SFP+ for 10GbE & long range.

Industry standard SFP+ connection allows for short, medium, and long range connections over fiber and supports Ethernet protocols from 1GbE to 10GbE.

NDI Tally that just works.

A full Tally system is built right into the 4K Family and it requires zero configuration. Includes a built-in large Tally light for your on-air talent to easily see which camera is live, plus user selectable Tally borders on loop out.

Cross Converter.

All 4K products include a built in cross converter and of the 12G SDI inputs can be looped out the HDMI 2.0 port and any of the HDMI 2.0 inputs can be looped out the 12G SDI.

PTZ Control.

With the optional USB to Ethernet dongle you can control any PTZ camera that supports NDI®, NDIIHX, or Visca over IP.

12G SDI

HDMI 2.0



BirdDog



BirdDog



BirdDog

BI-COLOUR TALLY
USB 3.0
AIRCRAFT GRADE
ALUMINIUM CASE

3.5mm HEADSET/MIC
SFP+
PoE
DC
4 LINE OLED

4K HDMI

4K 12G SDI

4K QUAD



1x HDMI 2.0 Input
1x HDMI 2.0 Output
1x 12 G SDI Output



1x HDMI 2.0 Output
1x 12 G SDI Input
1x 12 G SDI Output



1x HDMI 2.0 Output
4x 12 G SDI Input/Output

*Pricing and specifications subject to change.

Product Specifications



25mm

85mm

135mm

4K FAMILY

Features & Specifications Comparison

Feature/Specification	4K HDMI	4K 12G-SDI	4K QUAD
SUPPORTED VIDEO FORMATS			
UHD 3840x2160	23.98, 25.00, 29.97, 30.00, 50.00, 59.94, 60.00		
HD 1920x1080p	23.98, 25.00, 29.97, 30.00, 50.00, 59.94, 60.00		
HD 1920x1080i	50.00i, 59.94i		
HD 1280x720p	50.00p, 59.94p, 60.00p		
VIDEO I/O CONNECTIVITY			
HDMI 2.0 Input	✓	-	-
HDMI 2.0 Output	✓	✓	✓*
12G SDI Input	-	✓	-
12G SDI Output	✓	✓	-
12G SDI Selectable Input/Output	-	-	4
AUDIO INPUT			
HDMI	2Ch, 48kHz	-	-
SDI	-	2Ch, 48kHz	2Ch, 48kHz
3.5mm AUDIO	Microphone/Line Input		
AUDIO OUTPUT			
HDMI	2Ch, 48kHz		
SDI	2Ch, 48kHz		
3.5mm AUDIO	Stereo Headphone/Line Output		
VIDEO CODEC SUPPORT			
NDI (Full bandwidth i-frame compression)	✓	✓	✓
DISPLAY			
Integrated 4-line OLED Status Display	✓	✓	✓
Integrated Multiviewer*	-	-	HDMI OUT
TALLY			
Onboard Bi-color Tally indicator	✓	✓	✓
Selectable Tally indicator on video loop outputs	✓	✓	✓
NETWORK CONNECTIVITY			
Ethernet RJ45 1000baseT w/integrated PoE (Power over Ethernet)	✓	✓	✓
Open SFP+ Cage (10gb SFP+ Adapters sold separately)*	✓	✓	✓
Embedded Web configuration Panel	✓	✓	✓
WEIGHTS & DIMENSIONS			
Size	135x85x25mm		
Weight	260g	260g	320g
POWER			
DC Input	DC 12V / 16W		
PoE (Power over Ethernet)	PoE+ 802.3at		
EXTERNAL INTERFACE SUPPORT (requires optional cables)*			
USB to RJ45 for additional network in device support	✓	✓	✓
USB to RJ45 for VISCA over IP PTZ control	✓	✓	✓
USB to Serial PTZ control (RS232)	✓	✓	✓
USB ISO recording	✓	✓	✓

* Feature coming soon with free firmware update.

SOFTWARE



BirdDog | CLOUD CONNECT

Cloud Connect. This changes EVERYTHING.

This is Cloud Connect. The game changing, globally scalable, totally interconnected video workflow with apps across Apple TV, Android TV, Apple iOS, Android, Windows, and MacOS. And of course the all-new BirdDog PLAY.

Preliminary Specifications & Subject to Change. Shipping Q3, 2021.

2 Frames Latency. We've gone to Plaid.

Cloud Connect provides the fastest connection to your live production or editorial workflow. In as little as 2 frames from source to screen, you can be monitoring your NDI feeds anywhere in the world on your BirdDog PLAY, iPad, Apple TV, iPhone, or Android device.

NDI® 5.

Cloud Connect integrates the amazing features of NDI® 5 including high bandwidth NDI, NDI® HX2, NDI® Remote, and NDI® Bridge. Learn more about all the amazing features of NDI 5 here.

Remote Editorial Workflows.

Editors can output Avid or Adobe timelines in NDI® using the free plugins. Producers, Directors, and anyone needing to monitor can all use BirdDog PLAY or the Cloud Connect apps to view and collaborate.

Remote Production Workflows.

With Cloud Connect it's easy to produce a Remote Production from anywhere in the world. Control the New York studio from London across the public internet with full PTZ control, Tally, and Talkback. Using BirdDog PLAY or the Cloud Connect suite of apps anyone who needs to monitor with as little as 2 frames latency.

Remote Monitoring. With Multiviews.

Monitor all your NDI feeds from anywhere in the world over the public internet. Set up a Multiview and watch it on your giant TV using BirdDog PLAY with Cloud Connect. Or use Apple or Android TV. It's just so easy.

Beautiful Vistas.

BirdDog Cloud Connect applications make navigation and use a breeze with cutting edge and beautiful user interfaces, no matter what device you have. Zoom in on your phone or lean back and watch on your TV.

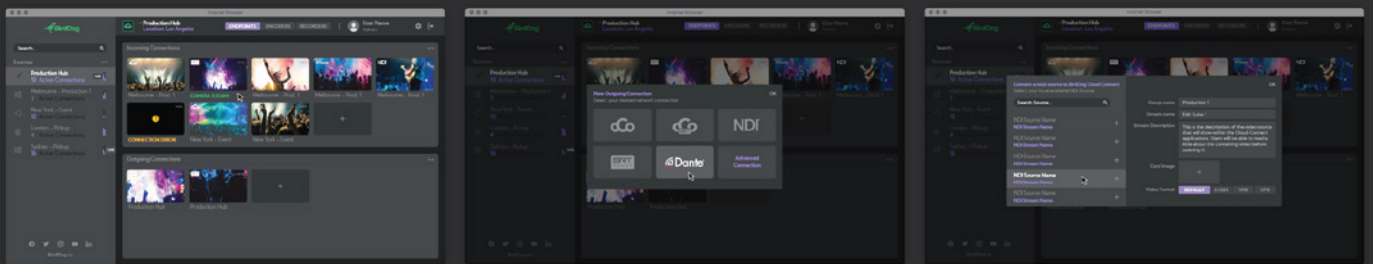

Dante or NDI. Flexible Audio.

With an optional BirdDog Cloud Dante licence (add on to regular BirdDog Cloud licence) you can select Dante audio to be sent to your Cloud Connect receiver.

PTZ Control. Tally.

PTZ control is a total breeze. When using Cloud Connect app on your phone you have PTZ control with your finger on the phone touchscreen. Tally is also sent with the NDI stream for maximum visibility of the production.

PTZ Camera Support.

Cloud Connect supports all NDI and NDI HX PTZ cameras from all manufacturers. So don't have a BirdDog PTZ? No worries!

Security? We got you.

Cloud Connect is totally secure. You can lock sessions to be one-on-one to avoid unwanted guest drop-ins as well as customising your session timeouts so people can't copy your connections.

Quality Control.

Cloud Connect is built for production and offers much higher quality than video conferencing. You can also adjust the quality levels to handle the fastest and toughest network environments.

Wi-Fi & 4G Friendly.

Connecting and monitoring your sources on the run has never been easier. Now you can monitor from airports, coffee shops, on the

run, or just chilling out on the beach drinking a piña colada.

No Firewall configuration.

Cloud Connect is totally network and IT admin friendly. There are no firewalls to configure allowing instant access to your NDI sources from anywhere.

Next-Gen Engine.

Say that 3 times fast.

Using the next generation BirdDog Cloud engine you can easily publish Cloud Connect sessions instantly, add in thumbnails and friendly names for easy identification. Underpinned by the latest NDI® 5 you can publish any source from anywhere on your network.

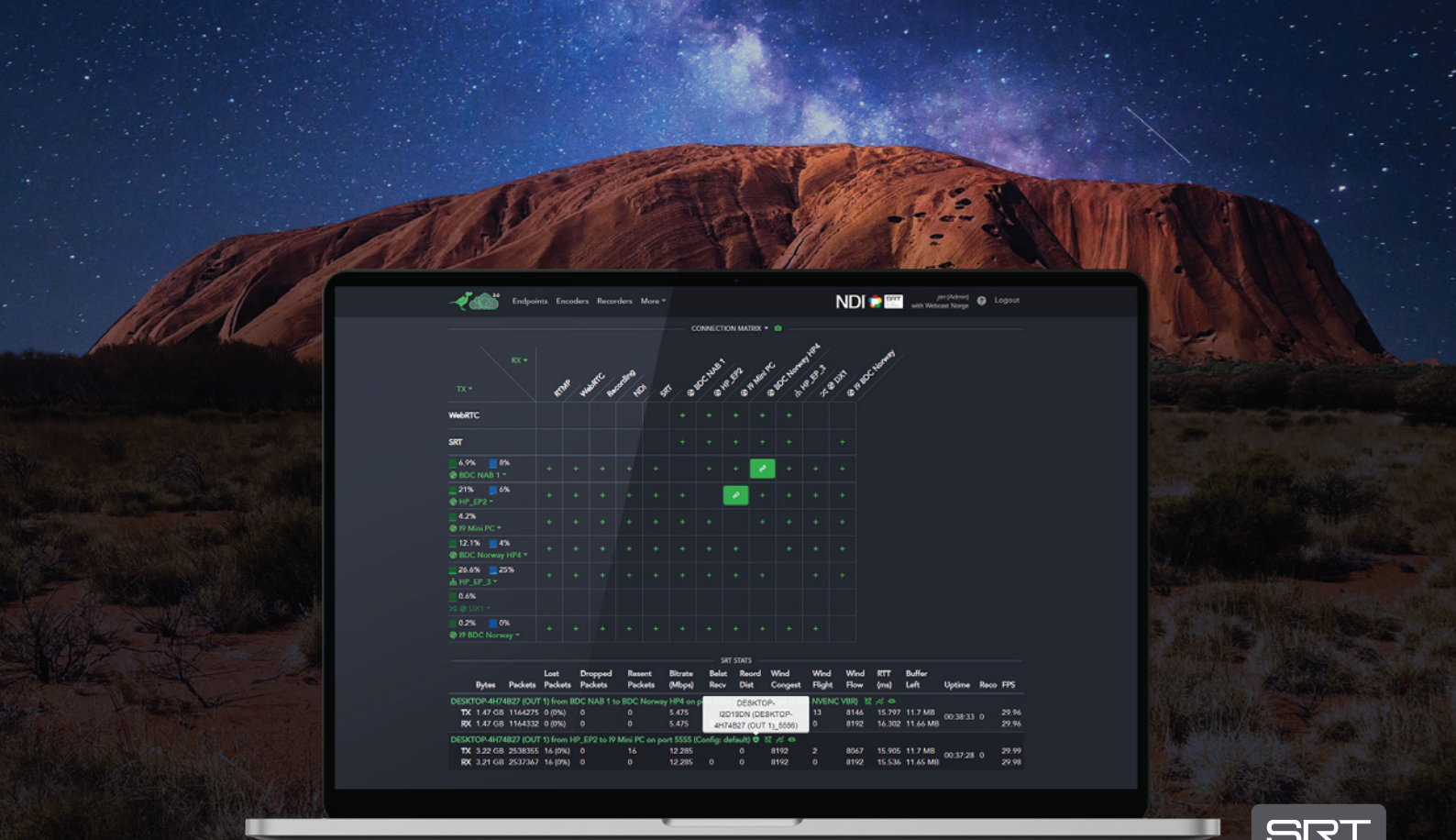

BirdDog | CLOUD 2.0

Send NDI® anywhere in the world with SRT encryption.

Cloud changes everything. Now you can expand outside your local network to distribute your NDI® content to anywhere in the world. Utilising SRT, Cloud has 128/256 bit AES encryption all way through the pipeline so you can send over the public internet with total peace of mind that your streams are secure. SRT video transport protocol also ensures reliable streams even over lossy networks.

The world just got smaller.

BirdDog Cloud allows for remote production from anywhere in the world. All you need is an internet connection and you can instantly and remotely access any NDI® enabled device. Cloud has complete integration with all the tools you need for a real-time remote production with support for NDI Tally, BirdDog Comms, and full PTZ control.

Ultra low latency.

Cloud is blazingly fast. The SRT integration means that even over lossy connections you can access any NDI® content anywhere in the world at ultra low latency. Want to remotely produce a live stream in Norway from Melbourne? BirdDog Cloud makes it possible.

PTZ Control, Tally, Comms? Check.

PTZ Control, Tally, and BirdDog Comms (free audio intercom software) are all totally integrated within Cloud. You can remotely control PTZ Cameras from the other side of the world, have complete talk back with your camera operators, and end to end Tally integrated into your production.

Total encryption. Total Security.

Cloud uses SRT video transport protocol which has optional end-to-end 128/256 bit AES encryption to ensure your content is protected from contribution to distribution. Whether it's a single point to point delivery or a single stream to multiple sites, you never need to worry about the security of your streams over the public internet.

Presenter Mode. Share your wisdom.

Non video producers can select sources and a presentation to display at the same time to create a truly engaging presentation. Perfect for schools, classrooms, and corporate communications. Use any web enabled device including iPads, smart phones, and laptops.

Automatic Failover.

Total Redundancy.

Cloud can automatically switch to a failover source on the RX endpoint. Simply select the backup source during set up and enable a separate TX Endpoint and RX Endpoint and you have full redundancy.



G'Day Dante.

Cloud Gen 2.0 now supports Dante with up to 8 channels per source and can also flip Dante into and out of NDI for maximum flexibility. Configure any option for Dante in / NDI out, NDI in / Dante out...or keep it Dante to Dante all the way through.

Portable monitoring.

With the WebRTC module you can monitor your NDI streams on an iPad, tablet or other portable device with close to zero latency.

Connection Manager.

Drag and drop your endpoints to create a connections. Once connected you will get an animated connection line confirming connection status.

Cloud Command.

The BirdDog Cloud Command web user interface is a centralized configuration, management, and monitoring portal. Inside Cloud Command you can quickly view all parameters of your stream, check statistics, and set up any of your connections with a simple drag and drop.

Everywhere and nowhere.

BirdDog Cloud resides on globally distributed platform based on AWS to ensure maximum reliability and availability. We're still not sure if this is some kind of sorcery or quantum superposition.

SRT. Goodness personified.

SRT stands for Secure Reliable Transport and is a video transport protocol that enables the delivery of high-quality and secure, low-latency video across the public Internet.

BirdDog Cloud uses SRT to create the link between endpoints and also supports SRT Caller/Listener, and rendezvous. Along with NDI BirdDog Cloud can also accept an MPEG-TS ingest from software such as Cinegy and vMix, or from hardware such as Haivision Makito, or Epiphan Pearl.

More informations at bird-dog.tv/cloud.

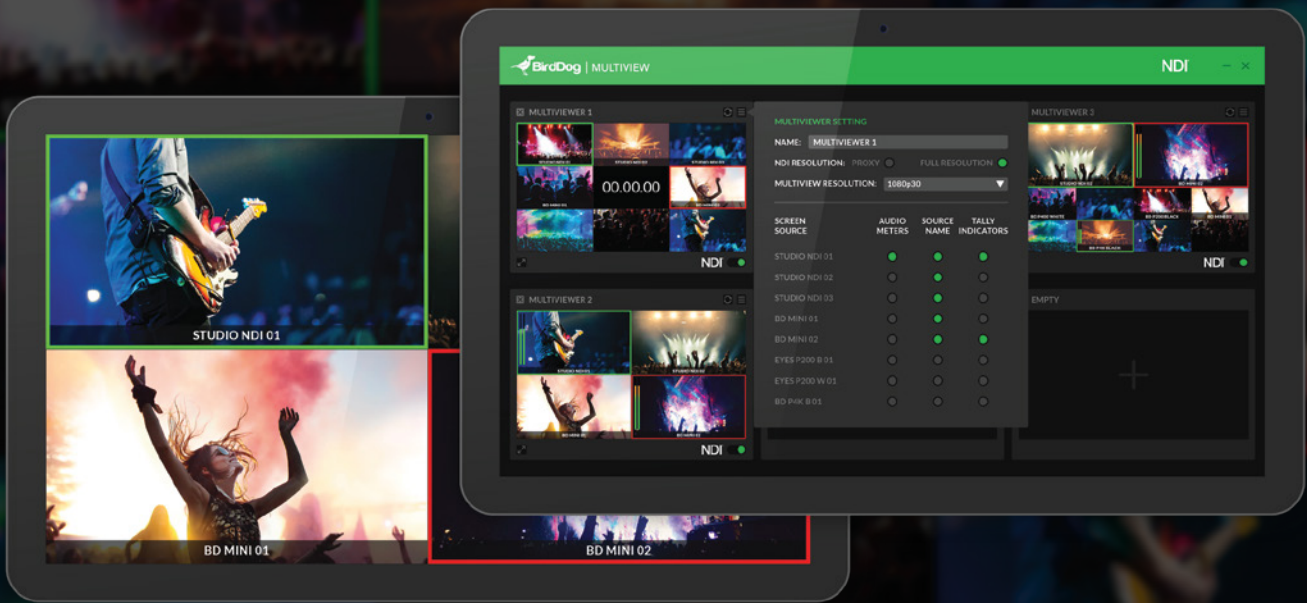

BirdDog | NDI MULTIVIEW

6 NDI Multiview Outputs. 5 Layout Options. 1 Powerful Software App.

NDI Multiview has been designed to be incredibly powerful and super intuitive to use. Create an NDI Multiview stream in a matter of seconds. Simply select the Multiview layout of your choice, select which NDI® source you want in each window, and select which overlays you wish to see. Toggle on the NDI® switch and you are sending a Multiview window out as a standard NDI® source. Yes. It really is that easy.

Create NDI Multiviews in Seconds.

NDI Multiview Pro supports up to 6 Multiview outputs and each can be independently configured with any of the 5 preset layouts. Choose between full screen, 2x2, 3x3, 4x4 and the traditional 2&8 (two large and eight small windows). With all NDI® sources on your network automatically detected you can create your NDI Multiview outputs in an insanely short amount of time. NDI Multiview Lite supports 6 outputs with a maximum layout of 2x2.

96 sources in Pro. 24 sources in Lite.

NDI Multiview Pro supports up to six 4x4 windows for a total of 96 independent NDI sources. NDI Multiview Lite has maximum of six 2x2 windows for a total of 24. That's a lot of NDI® flying around the place but don't worry, we never cross the streams.

Full Screen Local Preview.

Once you have decided upon your layout and overlays you can view that Multiview on your local machine.

Receive in software or hardware.

Multiview outputs a standard NDI stream per window which can be received on any Mac or PC running NDI Tools, any NDI compatible software based switcher, or use a BirdDog NDI Decoder to send back out to baseband video.

Compatible with Central.

The NDI Multiview outputs are a standard NDI stream you can use Central to route the streams to BirdDog NDI Decoders.

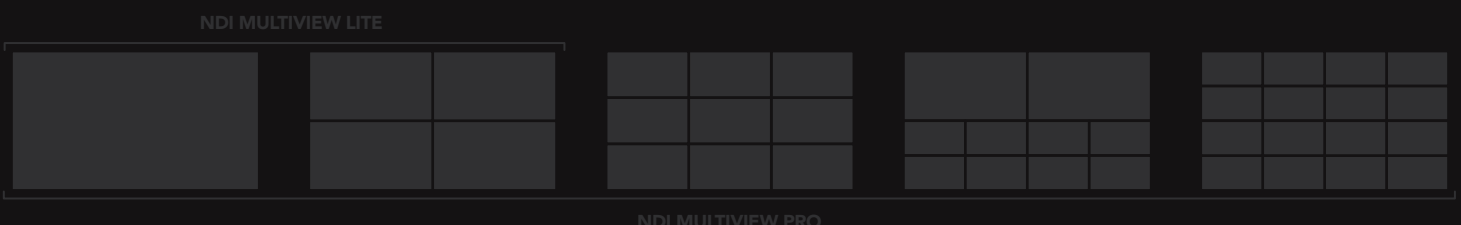

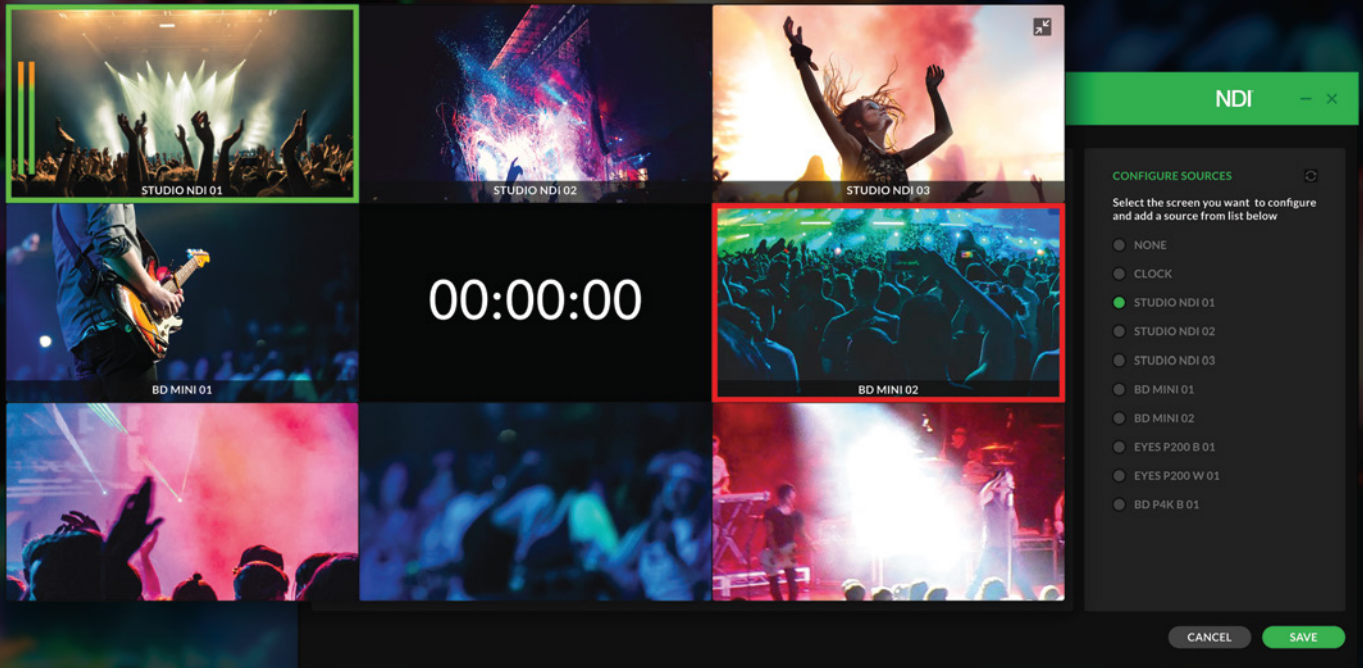

Selectable overlays per window.

Each window within NDI Multiview can have its own customised overlays. Simply toggle on or off in the setup.



Audio Levels.

VU Meters that run vertically on the left-hand side of each window.

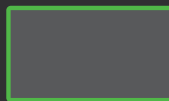

Tally.

BirdDog's signature tally border overlays.



Source Labels.

Select the NDI Source name to display at the bottom of the window.

Bandwidth concerns? We got you.

NDI Multiview has a bunch of options to help you save on network bandwidth.

Proxy Support: Use the low bandwidth 6Mbps NDI Proxy as a source.

Output Resolution: Choose between 720p and 1080p.

Output Framerate: Drop the frame rate down as low as 1 frame per second.

Multicast: Using Multicast you only put one stream of NDI onto the network and each stream can be picked up multiple receivers.

Output Toggle: Toggle between NDI output on and off to save bandwidth if Multiview window not in use.

Receive in software or hardware.

Multiview outputs a standard NDI stream per window which can be received on any Mac or PC running NDI Tools, any NDI compatible

software based switcher, or use a BirdDog NDI Decoder to send back out to baseband video.

Compatible with Central.

The NDI Multiview outputs are a standard NDI stream you can use Central to route the streams to BirdDog NDI Decoders.

Audio Track Selector.

Select an audio track from any of the NDI inputs to send with the NDI Multiview.

System Requirements

Windows 10 and above. Intel Core i5 series processor and above recommended.



FREE

BirdDog | COMMS Lite

Enter the World of NDI® Audio Intercom.

Comms Lite is the entry point to the world's only audio intercom platform that supports video preview windows. With support for four BirdDog devices, plus a director, Comms Lite is a great way to start using Audio Intercom in your live productions. And it's free for all BirdDog hardware customers.

Four BirdDog's. One Director.

Comms Lite supports up to four BirdDog devices and one Director licence.

Touchscreen.

Use a Windows 10 Pro enabled touchscreen tablet for a touchscreen experience.

Auto source detection.

Comms Lite automatically detects all your BirdDog compatible devices so you can easily select which four you want to use. Super easy to set up and use.

100% Free.

Simply log your details on our website on the Comms Lite page and we'll send you Comms for free.

Comms Features	Lite	Pro
Groups	1	5
Max BirdDog's per group	4	6
Live video windows	4	12
Director Push to Talk buttons	1	3

Comms Features	Lite	Pro
Director to All	✓	✓
BirdDog to Director	✓	✓
Mute Camera Operator	✓	✓
Shortcut to Web Console	✓	✓
Monitor Camera Audio	✓	✓



BirdDog | COMMS PRO

World's Best NDI® Audio Intercom System.

Harnessing the true power of NDI®, BirdDog Comms Pro is the world's first audio intercom system integrating live camera feeds. Be in total control and see every angle of your live production with live video windows from every BirdDog NDI® enabled camera source.

5 party lines.

With video windows available for all the BirdDog Encoded NDI® Sources, your director now has vision of all the cameras at their fingertips.

Intuitive group management ensures everyone is on the right channel.

Push to talk.

Your camera operators can simply push your call button on any 4 Pole TRRS headset and talk to the group you have been set up in. On the directors side you simply push any of the groups to talk to that group.

Auto-source detection & touchscreen.

Comms Lite automatically detects all your BirdDog compatible devices so you can easily select which four you want to use. Super easy to set up and use.

Use a Windows 10 Pro enabled touchscreen tablet for a touchscreen experience.

Comms Features	Lite	Pro
Auto detect NDI Sources	✓	✓
Volume sider bar	✓	✓
BirdDog Push to Talk	-	✓
Director to Group	-	✓

Comms Features	Lite	Pro
BirdDog Operator Broadcast	-	✓
Mix Minus	-	✓
Keyboard shortcuts / hot case	-	✓
Refresh NDI Sources	-	✓

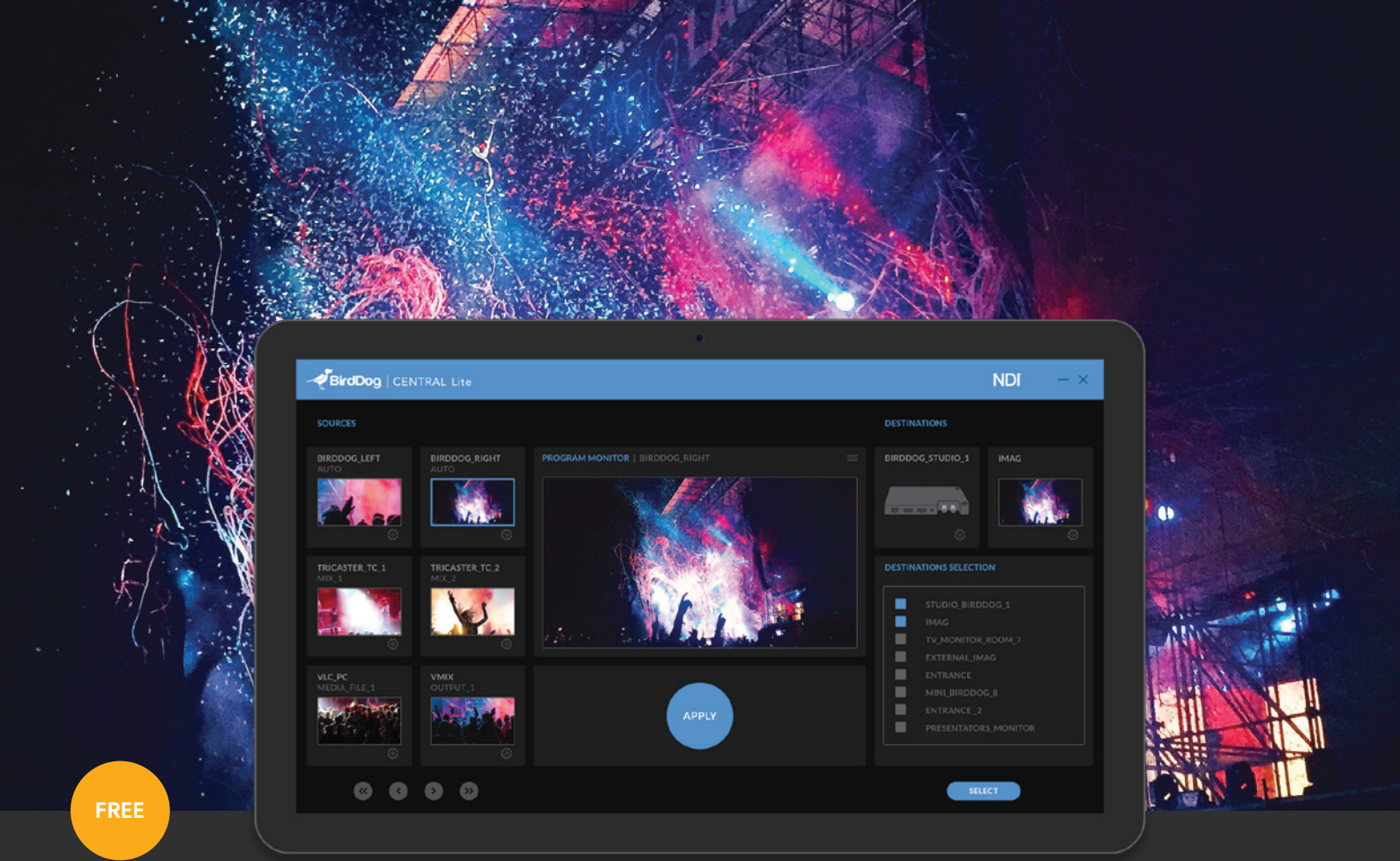

BirdDog | CENTRAL Lite

Enter the world of NDI® Routing.

Central Lite is the entry point to NDI® routing on a platform that supports live video preview windows.

By teaming up Central Lite with any NDI® source, including all BirdDog hardware capable of creating NDI® sources, you can now drive your NDI® streams to any BirdDog decoder.

100% Free.

Simply log your details on our website and we'll send you Central Lite for free.

Touchscreen.

Use a Windows 10 Pro enabled touchscreen tablet for a touchscreen experience.

Three clicks.

Simply select your source, select your destination, and click apply. Now you are sending your NDI® content to a single BirdDog hardware decoder or any of your groups.

Unlimited sources. Two destinations.

Central Lite supports unlimited Full NDI® sources and two BirdDog hardware destinations.

Central Features	Lite	Pro
Sources	Unlimited	Unlimited
Destinations	2	Unlimited
Source Active Status	-	✓
Favourites Sources	-	✓

Central Features	Lite	Pro
Fav. Destinations	-	✓
Groups	-	✓
Number of Groups	-	5
Devices in Groups	-	Unlimited
NDI Decoder Support	BirdDog	BirdDog

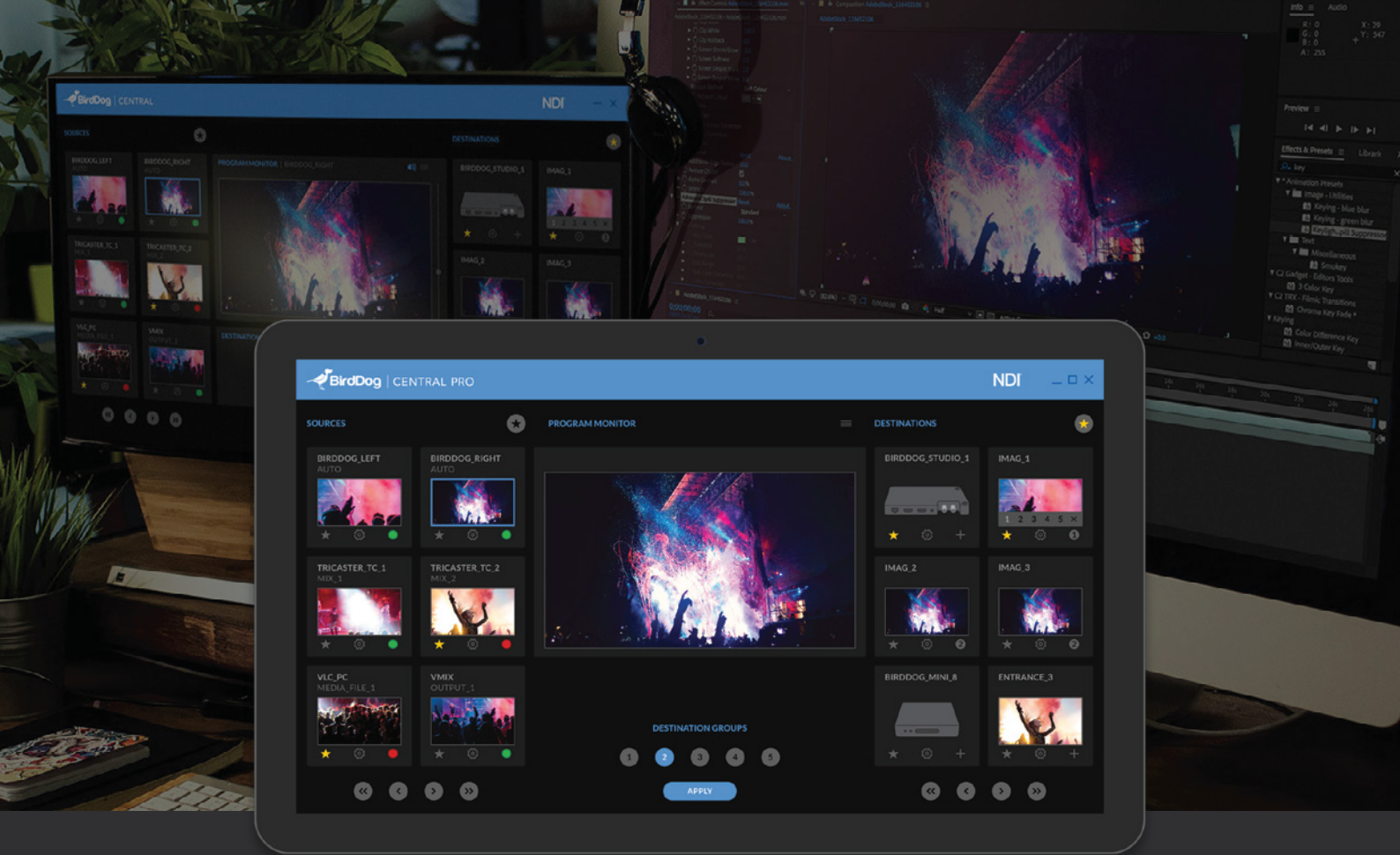

BirdDog | CENTRAL PRO

NDI® Distribution Made Easy.

BirdDog Central is a software platform set to redefine the way we think about driving content to TV screens. By teaming up Central with any NDI® source, including all BirdDog hardware capable of creating NDI® sources, you can now drive your NDI® streams to any BirdDog Studio NDI or Mini to decode NDI® back to SDI or HDMI.

Three clicks.

It's really that easy to get NDI® content onto your screens. Simply select your source, select your destination, and click apply. Now you are sending your NDI® content to a single BirdDog hardware decoder or any of your groups anywhere on the network.

5 Groups.

By grouping your BirdDog NDI® Decoders you can instantly drive content to multiple screens. Gang up 10, 20, or even hundreds of receivers and push the NDI® content to your group with just three clicks. With Central it's so easy to create the groups, simply select and assign to a group.

Large video preview window.

With the large live video preview window you can easily monitor any NDI® source. Simply click the list button and select any NDI® stream on the network to bring that up in the Program Monitor window.

BirdDog compatible.

Central is compatible with all BirdDog hardware generated NDI® sources including Studio NDI, Mini, and of course the ground-breaking PTZ Line. These will show up automatically in your source windows and you can then choose which destinations to send them to.

Any NDI® source.

Central will work with any full version NDI® source on your network, whether it is a feed from a live BirdDog PTZ Camera, a BirdDog Encoder, a file playing off a computer, or the output from an NDI® compatible switcher. Any of your NDI® sources will show up in Central and you can push that to your BirdDog Studio NDI or Mini and they'll play nice and decode it back to baseband video for you.

Touchscreen.

Use a Windows 10 Pro enabled touchscreen tablet for a touchscreen experience.

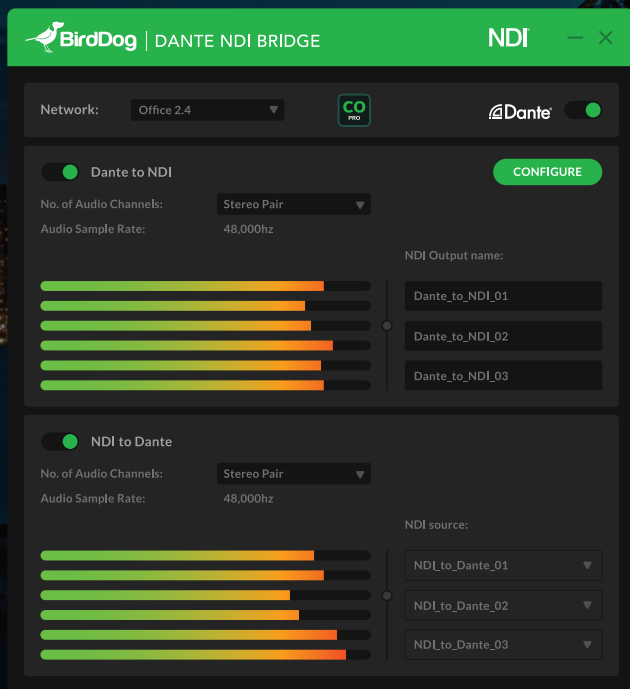

DANTE NDI BRIDGE

CONNECT YOUR IP WORLDS

Dante NDI Bridge is a Windows 10 application for flipping audio tracks between NDI® and Dante®. With support for up to 3 stereo pairs, Dante NDI Bridge can receive 3 NDI® streams and create 3 stereo pairs of Dante® audio, or receive a single NDI® stream and create 3 Dante® stereo audio pairs. All this in sub-frame latency and of course the same applies in reverse.

BirdDog | TOGETHER

FOR ALL EDUCATIONAL FACILITIES, HOUSE OF WORSHIP, NOT FOR PROFITS.



Free Central Pro and Comms Pro Offer.

BirdDog is pleased to offer Central Pro and Comms Pro free to all Educational Facilities, House of Worship, and Not for Profit organisations.

BirdDog Central Pro and Comms Pro require compatible BirdDog hardware in order to function correctly.

To claim your licences please email together@bird-dog.tv with your proof of purchase of relevant BirdDog hardware and ensure the email is sent from a registered email address of the organisation claiming the software.

FREE

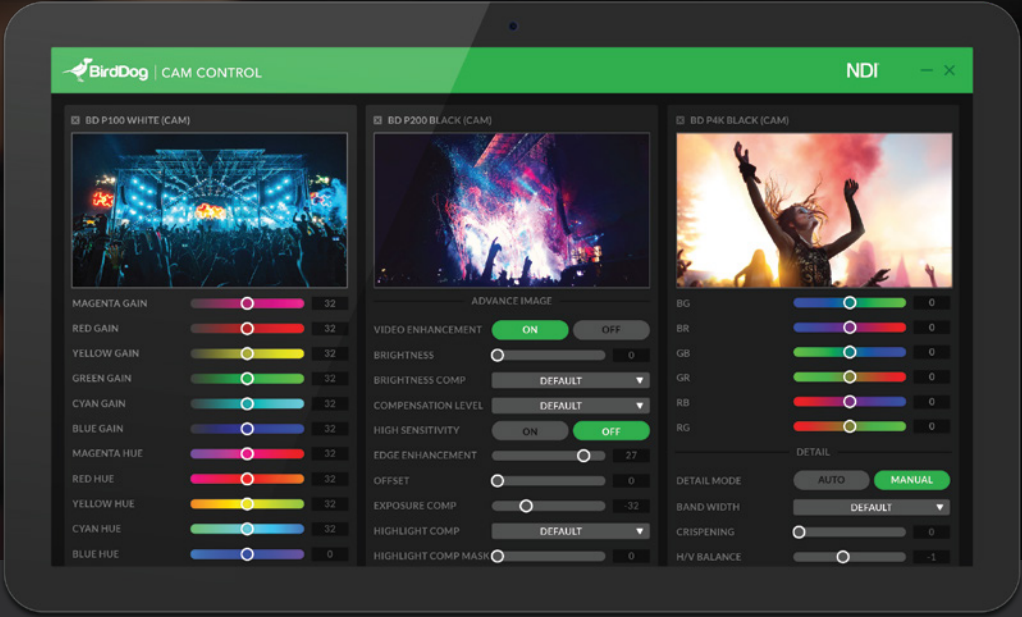

BirdDog | CAM CONTROL

Colour match cameras in seconds.

The free Cam Control app is the easiest and most user-friendly way to dial in BirdDog cameras. Simply load on a Windows 10 machine on the same network as your BirdDog cameras and access all functions of the camera through a beautiful interface. Quickly dial in the look you like and easily match multiple cameras.

Realtime Sync.

The unparalleled flexibility of BirdDog cameras means there are multiple ways to access each setting. You can use Cam Control for remote shading and colour matching, the On Screen Display (OSD) via the remote control, the controls on the BirdDog PTZ Keyboard, or by using the Web Dashboard. Now as soon as you make a change anywhere it will realtime sync to everywhere else.

P400 and P4K tools included.

P400 and P4K have an unbelievably powerful set of colour tools, exposure and gamma controls, and so many more powerful features. Now you have access to them all within Cam Control.

Save and Recall Pre-sets.

As if Cam Control wasn't already the fastest and easiest to use camera shading tool on the planet, you can also save and recall camera pre-sets. Load your saved settings up on your next job, copy across all cameras in just seconds, and then sit back and work out what you are going to do with all that time you just saved. We strongly suggest cat videos on YouTube.

Full Screen Confidence Monitor.

Load up the BirdDog PTZ cameras you want to work with and right click to output to a full screen confidence monitor to dial in the exact look you are after.

Direct text entry. Tuning made easy.

Slider bars are great for quick control but sometimes can be hard to dial in the exact levels you need. To change a value from 89 to 88, just click in the direct text box next to the slider bar and type 88. It's really that easy.

Scales with camera capabilities.

Some BirdDog cameras such as P4K have more colour adjustment capabilities such as black level and gamma control. If the camera supports these extra features the access to them will appear automatically in Cam Control.

Full user interface at bird-dog.tv/camcontrol

AV SECTION

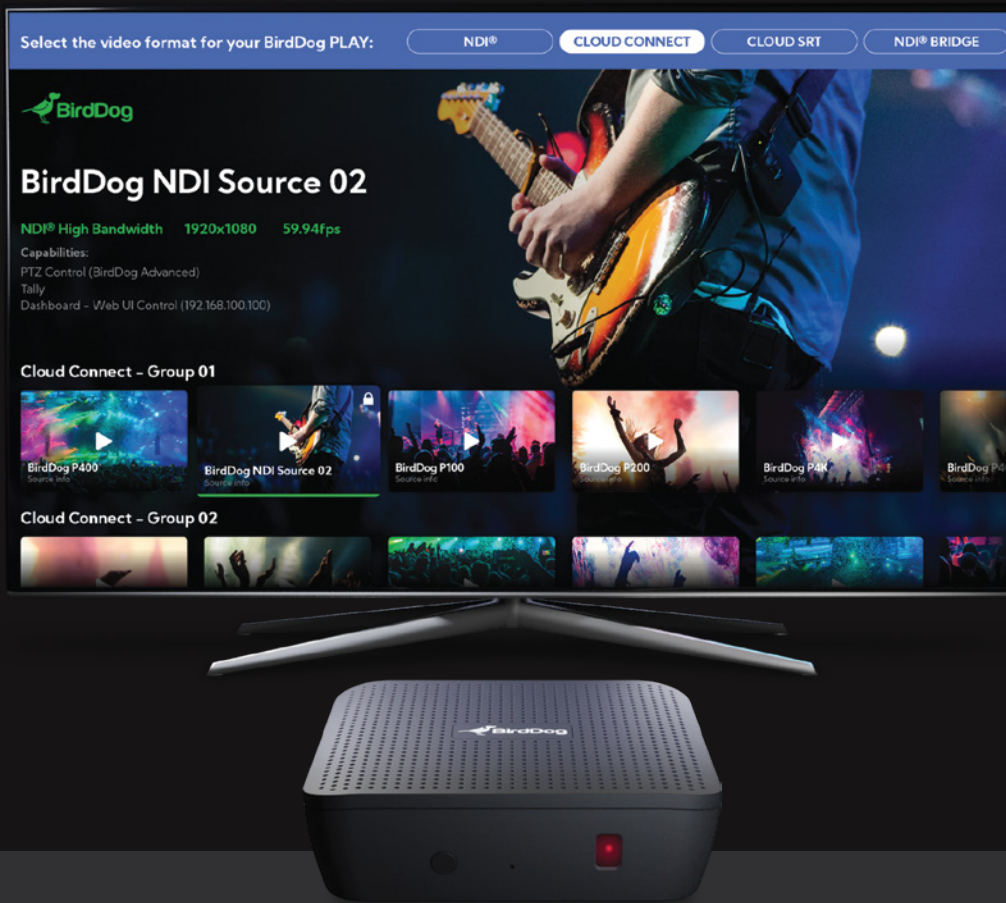

Hello World. Come PLAY.

Meet PLAY, the newest and smallest 4K NDI Player on the planet with full support for NDI® 5. Now connections are a breeze, simply connect PLAY to your NDI network, plug it into your TV via HDMI, and use your own remote to browse the new and gorgeous interface.

Preliminary Specifications & Subject to Change. Shipping Q3, 2021.

NDI® 5.

PLAY supports all the new NDI® 5 functions including high bandwidth NDI, NDI® HX2, NDI® Remote, and NDI® Bridge. Learn more about all the amazing features of NDI 5 here.

Tiny footprint.

Play measures just 85mm x 85mm x 19mm and only weighs 97grams.

Magnetic Base. Non-slip grip ring.

Attach PLAY behind your TV screen with the built-in magnet or sit in front of the TV confidently with its non-slip rubberised grip ring.

4K UHD. HDMI 2.0

Receive NDI in resolutions all the way up to 4Kp60. (Not all versions of NDI® 5 will be able to support 4Kp60.)

USB Power.

PLAY is powered by standard USB-C for maximum flexibility.

CEC control. BYO remote.

The built-in CEC control lets you use your own remote to browse and play NDI sources.

Incredible API support.

RESTful API, Crestron control module, Zoom API, Q-SYS API. You name it, PLAY supports it.

Beautiful interface.

Navigation to your NDI sources is an absolute breeze within the gorgeous PLAY interface.

Automatic source detection.

PLAY automatically scans your network for NDI sources and brings them up with a thumbnail view.

BirdDog Cloud Connect.*

Integrate PLAY with BirdDog Cloud Connect to use as a viewer for all your global BirdDog Cloud endpoints. Browsing is super intuitive, and the speed of connection is lightning fast. High-quality video in as little as 2 frames from anywhere in the world. Yes. You read that right. 2 frames latency.



TOP



BOTTOM



Product Specifications

Supported Video Formats**

UHD 2160p – 25, 29.97, 30, 50, 59.94, 60
 HD 1080p – 25, 29.97, 30, 50, 59.94, 60
 HD 720p – 50, 59.94, 60

Video I/O Connectivity

1x HDMI 2.0 – Full size connector

Audio I/O Connectivity

HDMI 2.0 – Audio output (Stereo)
 3.5mm Analog – Audio output (Stereo)

Video Codec Support

NDI® – High Bandwidth i-frame, low latency
 NDI® HX2 – h.264/HEVC long-GOP
 BirdDog Cloud Connect – Ultra-low latency,
 Internet delivered with discovery
 NDI® 5 Bridge – YES
 NDI® 5 REMOTE- YES, token based

Network Connectivity

Ethernet RJ45 1000baseT

Weights and dimensions

Dimensions: 85mm x 85mm x 19mm
 Weights: 97g
 Mounting Integrated magnetic base and
 rubber feet

Power

Power Input: USB-C
 Voltage: 5V DC
 Current: 1.2A

** Cloud Connect requires an additional licence.
 See BirdDog Cloud Connect page for more details.*

*** Video decode resolution support may vary based on video CODEC in use,
 maximum video output resolution is 2160p60.*



BirdDog | WALLPLATE

NDI Wallplates for Building the Ultimate AV Experiences.

NDI Wallplates are the answer to elegant and permanent NDI® installations. With two models to choose from, Dual Input or Dual Output, they have been designed to make boardroom setups a breeze. Install the Dual Output in the wall to drive content to the TV screens and install the Dual Input into the meeting table to take inputs from laptops and other devices using EDID.

Wallplate Input.

Wallplate Input features two independent inputs, each with EDID, and is designed for connecting cameras, laptops, and other devices to convert them into the world of NDI®. Perfect for installation into boardroom tables, meeting spaces, lecterns, stages, and anywhere you have sources that need to convert to NDI®. There is also a mic input.

Wallplate Output.

Wallplate Output features two independent outputs and is designed for driving content to screens. Output the video conferencing group to one screen and output the presentation or laptop screen share to

another screen to make for super engaging meetings. There is also a speaker output for connecting to an audio system.

RESTful API.

BirdDog Wallplates are programmable via the free RESTful API. It's never been easier to integrate NDI® into automated and integrated AV solution no matter what the overarching system is.

HDMI Auto Detection with EDID.

Wallplate Input has complete EDID to automatically convert your laptop's HDMI input into a supported resolution to send to Wallplate Output. This makes for a seamless

user experience in boardrooms and anywhere you need to get your PC onto a TV.

One Cable for PoE, Video, Audio.

NDI Wallplates are powered by PoE, so you only need to run a single Ethernet cable to power the units, along with carrying video and audio. One cable to rule them all.

Extreme Speed. It's all about the silicon.

BirdDog's revolutionary custom silicon chip is what drives the best NDI® products on the planet. Only BirdDog's hardware can do line-based processing to give the fastest NDI® possible.



Wallplates are all built upon BirdDog's custom NDI chip and can be totally automated via the programmable RESTful API, and also feature PoE for single Ethernet cable functionality, Mic Input, Speaker output, interchangeable faceplates, soft glow status indicators, and a easy to use web management console to change settings.

Wallplate Input Preliminary Specs

Video Format

(HD) 1080p 23.98, 25, 29.97, 50, 59.94

(HD) 1080i 25, 29.97

(HD) 720p 50, 59.94

Video Input

2 x HDMI Standard Type A connector

HDMI v1.4a, RGB or YCbCr with EDID

Audio digital

2-Channel, 24-bit HDMI embedded audio,

48 kHz sample rate, synchronous

Audio analog

3.5mm microphone input • 3.5mm stereo output

Video Codec support

Realtime, ultra-low latency, full-bitrate NDI

(i-frame)

Soft glow Indicators

User definable status indicators to show

active/non-active connections.

Network Interface

10/100/1000 Ethernet (RJ-45) with PoE

(Power over Ethernet)

Embedded web configuration panel for

control and firmware updates

Power

Power over Ethernet (PoE) 802.3af/at

Wallplate Output Preliminary Specs

Video Format

(HD) 1080p 23.98, 25, 29.97, 50, 59.94

(HD) 1080i 25, 29.97

(HD) 720p 50, 59.94

Video Output

2 x HDMI Standard Type A connector

HDMI v1.4a, RGB or YCbCr

Audio digital

2-Channel, 24-bit HDMI embedded audio,

48 kHz sample rate, synchronous

Audio analog

3.5mm microphone input • 3.5mm stereo output

Video Codec support

Realtime, ultra-low latency, full-bitrate NDI

(i-frame)

Soft glow Indicators

User definable status indicators to show

active/non-active connections.

Network Interface

10/100/1000 Ethernet (RJ-45) with PoE

(Power over Ethernet)

Embedded web configuration panel for

control and firmware updates

Power

Power over Ethernet (PoE) 802.3af/at

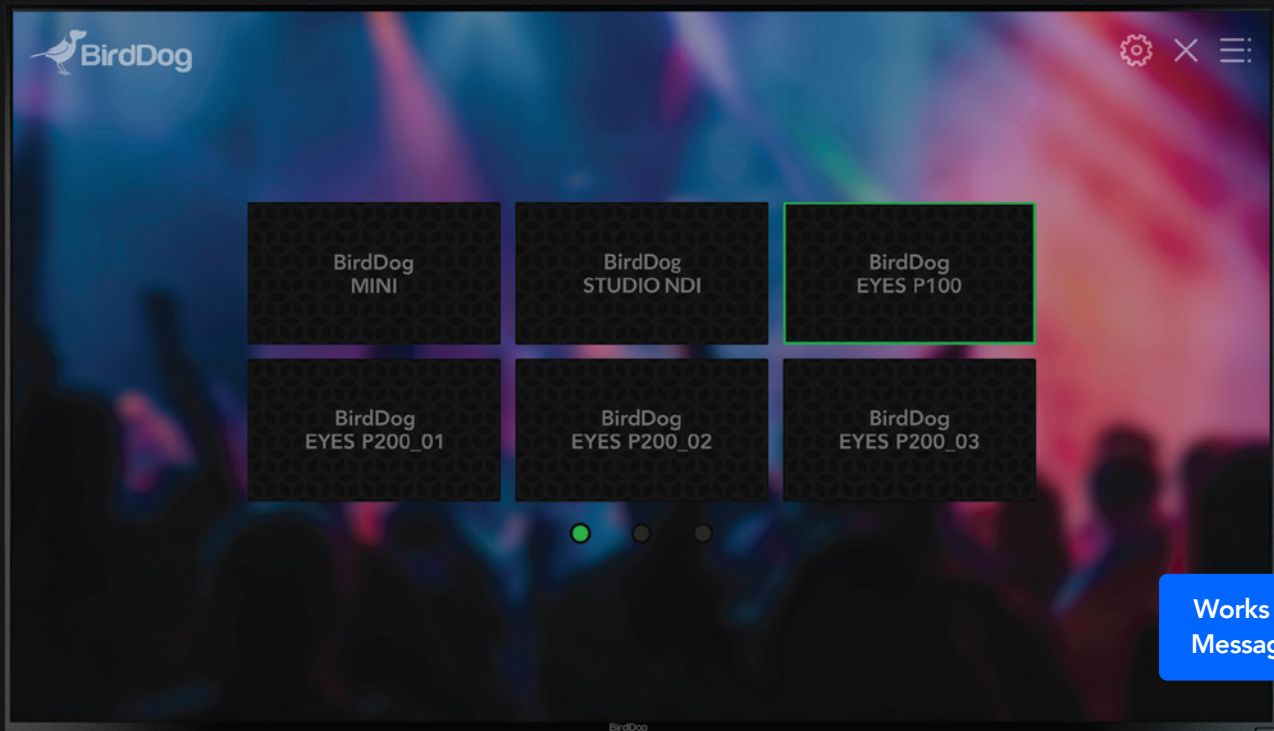

BirdDog | SDM FAMILY

The ultimate NDI® experience integrated.

Built upon Intel® SDM platform the BirdDog SDM Family will revolutionise the way content is distributed to even the largest installations. Simply install the SDM module inside an SDM compatible flat panel display for the most integrated and scalable NDI® to screen solution available. No more wall boxes or patch panels, now the AV distribution is built directly into the display.

SDM Family.

Controlled by the all in one BirdDog OS and with two BirdDog SDM modules to choose from, M1 an M2, there is a solution for every project. M1 is a full NDI Sender and Receiver based on the Intel SDM-L form factor and M2 is an NDI® Receiver built on the Intel® SDM-S module. With support for resolutions all the way up to 4Kp60, there is also a RESTful API for programming completely automated spaces.

BirdDog OS.

BirdDog have created a complete Operating System for Intel® SDM platform, simply called BirdDog OS, to give a truly integrated NDI® distribution system. Underpinned with BirdDog's technology, BirdDog OS has built in Crestron control and a RESTful API for complete automation.

M1.

M1 is an NDI® Sender and Receiver module based upon the Intel® SDM-L module. Receive NDI® from anywhere on the network to display on screen. With the Send function you can plug a source such as a laptop in and then duplicate that across any number of additional BirdDog Display activated screens.

STATUS PAGE:

Name	MyScreen
IP Address	192.168.100.100
DHCP/STATIC	DHCP
Current Operating Mode	Decode
Current Screen Resolution	3840 x 2160p60
Current NDI Decode Resolution	3840 x 2160p60
Current NDI Encode Resolution	Not Active
Serial number	12345
Firmware version	1.0.0
NDI Version	4.5.0

RESTART DEVICE

RESTART VIDEO

SETTINGS PAGE:

Operation:

Operation Mode: ENCODE **DECODE**

Screen Resolution: 3840 x 2160p60

Display mode: Follow HDMI Input

No video source behaviour: **STANDARD** BLACK CUSTOM

Dante audio: **ENABLE** DISABLE

Network:

Screen Name: MyScreen

IP Configuration: **DHCP** STATIC

IP Address: 192.168.100.100

IP Subnet: 255.255.255.0

Security:

Set screen PIN: *****

NDI SOURCES

- ★ BD 4K QUAD
- ★ STUDIO NDI
- ★ BD EYES P200_01
- ★ MINI
- ★ BD 4K HDMI
- ★ BD EYES P200_02
- ★ BD 4K 12G SDI
- ★ BD EYES P200_03
- ★ BD EYES A200
- ★ **BD EYES P100**
- ★ BD EYES P4K_01
- ★ BD EYES P4K_02

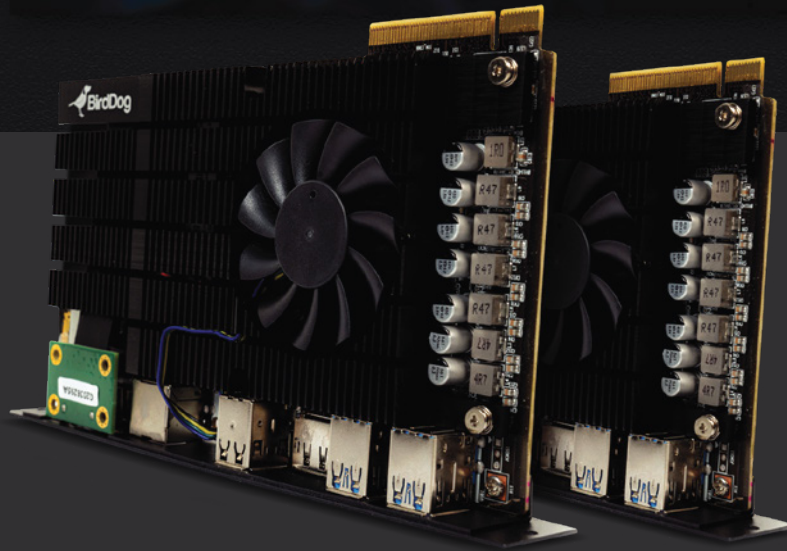

M2.

M2 is an NDI® Receiver module based upon the Intel® SDM-S module. Receive NDI® from anywhere on the network to display on screen.

Beautiful Interface.

The best user experiences are built upon easy to use interfaces. BirdDog OS features a clean and elegant design to make it super intuitive and easy to switch sources.

Multiple Sources.

Harnessing the power of NDI®, BirdDog Display can receive see virtually unlimited number of NDI® sources on the network. Simply use a remote control or any pointing device to bring that source to full screen.

RESTful API. Crestron Control Library.

BirdDog Display has a complete RESTful API for programming your own automation as well as a Crestron Control Library.

Distribute NDI® content everywhere. Just add Central.

BirdDog Central is a software platform set to redefine the way we think about driving content to TV screens. By teaming up Central with any NDI® source, including all BirdDog hardware capable of creating NDI® sources, you can now drive your NDI® streams to any BirdDog Studio NDI or Mini to decode NDI® back to SDI or HDMI. For more information see Central page.

Crestron Control.

BirdDog's Crestron Control Library is a collection of examples and documentation to allow integration of BirdDog products within standard Crestron protocols. It includes a simple user interface for controlling BirdDog PTZ cameras and recalling positions, as well as routing NDI sources to BirdDog hardware decoders such as NDI Wallplates, SDM Modules, and converters.

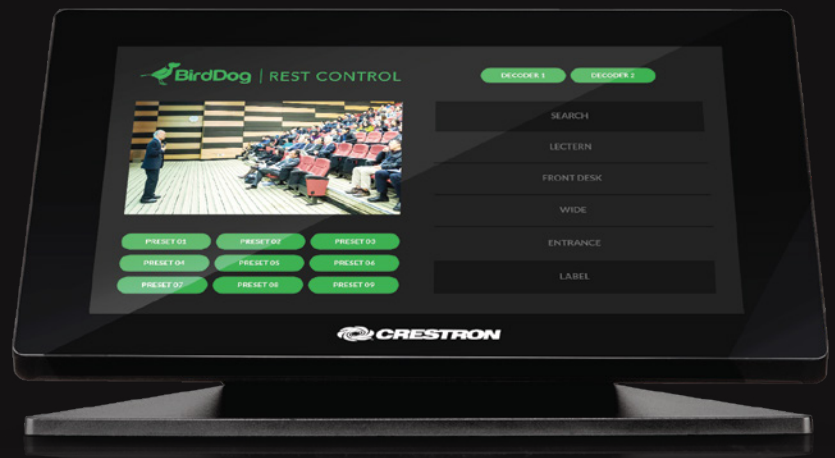

RESTful API.

Download the free BirdDog RESTful API and program your own automation for all BirdDog hardware endpoints, including cameras.

BirdDog Helpful Links

Unlock the latest features by updating firmware
www.bird-dog.tv/firmware

Activate your warranty by registering
www.bird-dog.tv/register

Download the latest manual
www.bird-dog.tv/docs

Help available
help@bird-dog.tv or www.bird-dog.tv/support

Join our user group
www.facebook.com/groups/BirdDogUsers



bird-dog.tv

hello@bird-dog.tv